

College Mathematics



First Edition



Scottsdale Community College

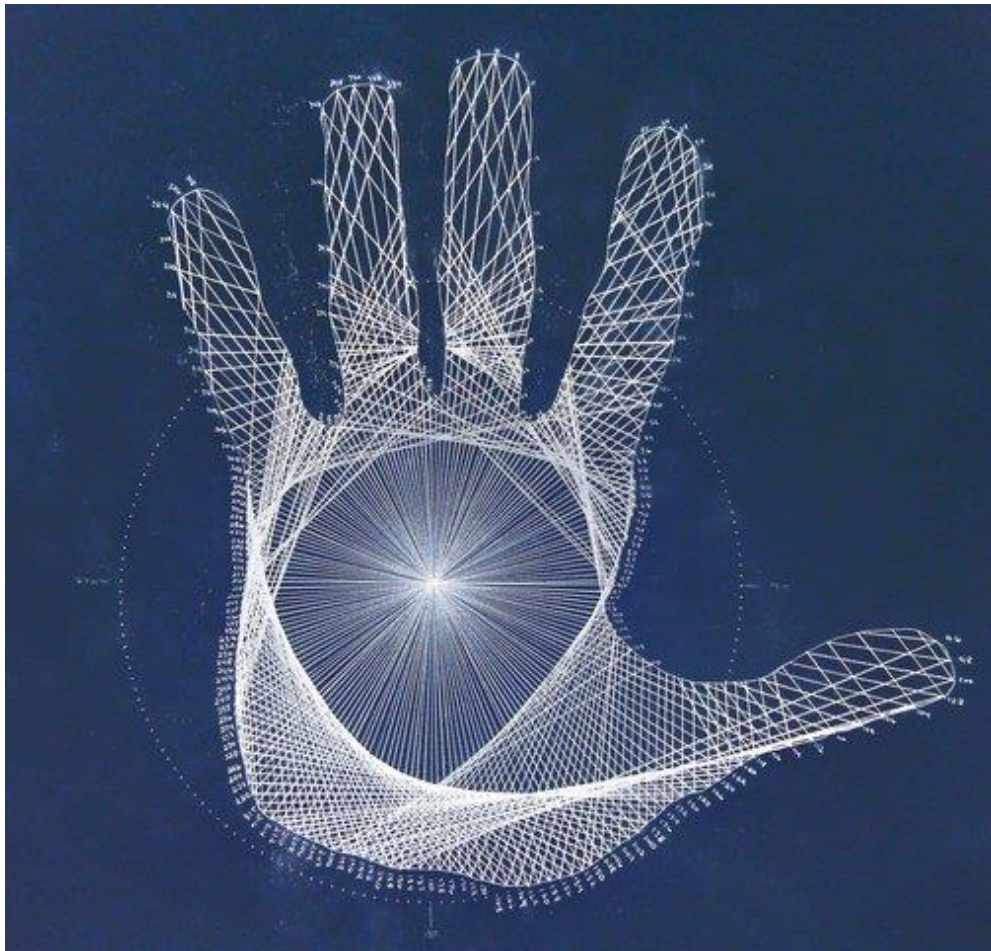

Image reprinted with permission by artist Jason Padgett

College Mathematics



First Edition

Development Team



Tracey Haynie, Scottsdale Community College

Jenifer Bohart, Scottsdale Community College

Carla Stroud, Scottsdale Community College

Portions of this textbook adapted from the following OER sources:



Geometry, Dimensional Analysis, Percentages, Savings and Loans, Sets, Probability, Statistics, Describing Data - “Math in Society” by David Lippman

Geometry, Percentages – “Basic Arithmetic Student Workbook, 2nd Ed.” by Scottsdale Community College

Functions, Linear Functions – “Introductory Algebra Student Workbook, 6th Ed.” by Scottsdale Community College

Functions, Linear Functions, Exponential Functions, Regression – “Intermediate Algebra Student Workbook, 4th Ed.” by Scottsdale Community College

Odds, CK-12 Foundation, <http://www.ck12.org/>

Measurement and Geometry, The NROC Project, http://nrocmath.org/products/higher-ed/developmental-mathematics/#contents_tab

Statistics Practice Problems - “Introductory Statistics” by OpenStax College
<https://openstax.org/details/introductory-statistics>



College Mathematics by Scottsdale Community College is licensed under a [Creative Commons Attribution-NonCommercial-ShareAlike 4.0 Unported License](https://creativecommons.org/licenses/by-nc-sa/4.0/).

Table of Contents

Chapter 1: Fundamentals of Geometry	1
Section 1.1 – Geometry Basics	1
Section 1.2 – Perimeter	2
Section 1.3 – Area	4
Section 1.4 – The Pythagorean Theorem	6
Section 1.5 – Circles	12
Section 1.6 – Perimeter and Area of Composite Figures	16
Section 1.7 – Working in Three Dimensions: Volume	21
Chapter 1 – Answers to You Try Problems	26
Chapter 1 - Practice Problems	28
Chapter 2 – Measurement and Dimensional Analysis	38
Section 2.1 – Length	38
Section 2.2 - Weight	41
Section 2.3 - Capacity	44
Section 2.4 - The Metric System	47
Section 2.5 – Converting Between Systems	53
Section 2.6 – Problem Solving Using Rates and Dimensional Analysis	57
Chapter 2 – Answers to You Try Problems	60
Chapter 2 - Practice Problems	61
Chapter 3: Linear Functions	65
Section 3.1 – Functions	65
Section 3.2 - Linear Functions	70
Section 3.3 – Linear Regression	77
Section 3.4 – Correlation	86
Chapter 3 – Answers to You Try Problems	89
Chapter 3 - Practice Problems	90
Chapter 4: Percentages	98
Section 4.1 – Percentage Basics	98
Section 4.2 – Applications Involving Percentages	99
Section 4.3 – Absolute and Relative Change	101
Section 4.4 – Percent Increase and Percent Decrease	104
Section 4.5 – Exponential Functions	106
Chapter 4 – Answers to You Try Problems	112
Chapter 4 - Practice Problems	114
Chapter 5: Savings	119
Section 5.1 – Simple Interest	119
Section 5.2 – Compound Interest	120
Section 5.3 – Annual Percentage Yield (APY)	124
Chapter 5 – Answers to You Try Problems	126
Chapter 5 – Practice Problems	127
Chapter 6 – Annuities and Loans	130
Section 6.1 – Annuities	130
Section 6.2 – Payout Annuities	137
Section 6.3 – Loans	140
Chapter 6 – Answers to You-Try Problems	145

Chapter 6 – Practice Problems	146
Chapter 7: Sets and Venn Diagrams	151
Section 7.1 – Set Basics	151
Section 7.2 - Union, Intersection, and Complement	153
Section 7.3 - Venn Diagrams	156
Section 7.4 - Cardinality	159
Chapter 7 – Answers to You Try Problems	161
Chapter 7 – Practice Problems	163
Chapter 8 – Introduction to Probability	173
Section 8.1 – Types of Probability	173
Section 8.2 – Basic Concepts	174
Section 8.3 – Complementary Events	177
Section 8.4 – Calculating Odds	178
Section 8.5 – Expected Value	182
Chapter 8 – Answers to You Try Problems	185
Chapter 8 – Practice Problems	186
Chapter 9 – Probability and Counting	189
Section 9.1 – Independent Events	189
Section 9.2 – Conditional Probability	191
Section 9.3 – “Or” Probabilities	194
Section 9.4 – Basic Counting	197
Section 9.5 – Permutations	200
Section 9.6 – Combinations	206
Chapter 9 – Answers to You Try Problems	210
Chapter 9 – Practice Problems	211
Chapter 10 - Statistics	219
Section 10.1 – Introduction to Statistics; Populations and Samples	219
Section 10.2 – Sampling Methods	223
Section 10.3 – How to Mess Things Up Before You Start	227
Section 10.4 – Experiments	229
Section 10.5 – Categorizing Data	233
Section 10.6 – Presenting Categorical Data Graphically	235
Section 10.7 – Presenting Quantitative Data Graphically	243
Chapter 10 – Answers to You Try Problems	248
Chapter 10 – Practice Problems	250
Chapter 11 – Describing Data	258
Section 11.1 – Describing a Distribution	258
Section 11.2 – Measures of Central Tendency	263
Section 11.3 – Measures of Variation	268
Section 11.4 – Quartiles, Five Number Summary, and Boxplots	272
Chapter 11 – Answers to You Try Problems	280
Chapter 11 – Practice Problems	282
Chapter 12 – The Normal Distribution	290
Section 12.1 – The Normal Distribution	290
Section 12.2 – The Empirical Rule	292
Section 12.3 - Standard Scores (z – scores)	294

Section 12.4 – Finding Percentages with Normally Distributed Variables	298
Chapter 12 – Answers to You Try Problems	305
Chapter 12 – Practice Problems	307
Appendix A - Answers to Practice Problems (Chapters 1-12)	313

Chapter 1: Fundamentals of Geometry

Chapter 1 Learning Objectives:

- Recognize the difference between one, two, and three dimensional objects
- Be able to find perimeter and area of standard and composite shapes
- Calculate the length of any side of a right triangle
- Find the area and circumference of a circle
- Find the volume of standard 3-Dimensional shapes
- Apply the geometric formulas to problem solve

Section 1.1 – Geometry Basics

Section 1.2 – Perimeter

Section 1.3 – Area

Section 1.4 – The Pythagorean Theorem

Section 1.5 – Circles

Section 1.6 – Perimeter and area of Composite Figures

Section 1.7 – Working in Three Dimensions: Volume

Section 1.1 – Geometry Basics

You use geometric terms in everyday language, often without thinking about it. For example, any time you say “walk along this line” or “watch out, this road quickly angles to the left” you are using geometric terms to make sense of the environment around you. You use these terms flexibly, and people generally know what you are talking about.

In the world of mathematics, each of these geometric terms has a specific definition. It is important to know these definitions - as well as how different figures are constructed - to become familiar with the language of geometry. Let's start with the most basic geometric idea: a point.

A **point** is simply a location, which has no dimensions! That might seem strange, but the geometric idea of a point is that it has no length, no width, and no height. The easiest way to visualize this is by imagining sticking the tip of a pin into a map. The pinpoint is serving to mark a location, not to measure an amount of space taken up by the tip of the pin itself.

While a point is a simple idea in geometry, it is a building block for more difficult geometric figures. Considering more than one point helps to build dimension in geometry. By considering any two distinct points, we now can form a **line** connecting the two points. A line is a one-dimensional figure (it has length, but no width and no height) that is made up of an infinite number of individual points placed side by side. In geometry all lines are assumed to be straight; if they bend they are called a curve. A line continues infinitely (forever) in two directions, usually indicated by placing arrows at the

two ends. A **line segment** does not continue infinitely in two directions, but has two endpoints, usually indicated by placing points at the two ends.



Putting it all Together: Figures on a Plane

A **plane** is a flat surface that continues forever (or, in mathematical terms, infinitely) in every direction. It has two dimensions: length and width. You can visualize a plane by placing a piece of paper on a table. Now imagine that the piece of paper stays perfectly flat and extends as far as you can see in four directions, left-to-right and front-to-back. This gigantic piece of paper gives you a sense of what a geometric plane is like: it continues infinitely in two dimensions. (Unlike the piece of paper example, though, a geometric plane has no height.)

A plane can contain a number of geometric figures, some of which we have already mentioned. Recall the most basic geometric idea is a point, which has no dimensions. A point is simply a location on the plane. It is represented by a dot. If we increase from one point on a plane to two points on a plane, we have a one-dimensional line. As we increase again, this time from 2 points to 3 points (that are not all on the same straight line), we now define the plane itself.

Section 1.2 – Perimeter

The perimeter of a two-dimensional shape is the distance around the shape. You can think of wrapping a string around the 3 sides of a triangle. The length of this string would be the perimeter of the triangle. Or walking around the outside of a park, you walk the distance of the park's perimeter. Some people find it useful to think “peRIMeter” because the edge of an object is its rim and peRIMeter has the word “rim” in it.

If the shape is a **polygon**--a closed, two-dimensional shape with straight sides-- then you can add up all the lengths of the sides to find the perimeter. Be careful to make sure that *all the lengths are measured in the same units*. You measure perimeter in linear units, which is *one dimensional*. Examples of units of measure for length are inches, centimeters, or feet.

Example 1

Find the perimeter of the given figure. All measurements indicated are inches.

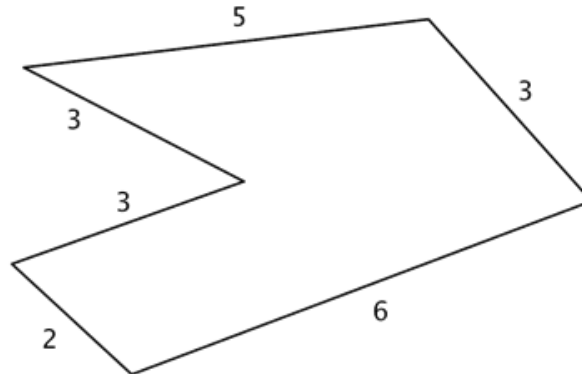

$$P = 5 + 3 + 6 + 2 + 3 + 3$$

Since all the sides are measured in inches, just add the lengths of all six sides to get the perimeter.

$$P = 22 \text{ inches}$$

(Remember to include units.)

This means that a tightly wrapped string running the entire distance around the polygon would measure 22 inches long.

Sometimes, you need to use what you know about a polygon in order to find the perimeter. Let's look at the rectangle in the next example.

Example 2

A rectangle has a length of 8 cm and a width of 3 cm. Find the perimeter.

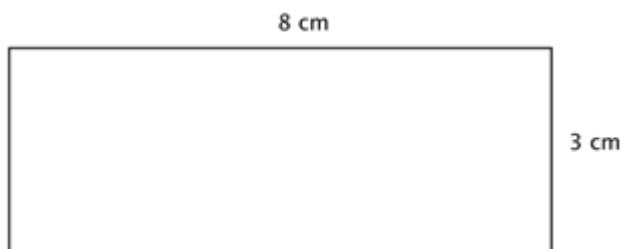

$$P = 3 + 3 + 8 + 8$$

$$P = 22 \text{ cm}$$

Since this is a rectangle, the opposite sides have the same lengths, 3 cm. and 8 cm. Add up the lengths of all four sides to find the perimeter.

You Try 1.2

Find the perimeter of each of the figures shown below. Be sure to include correct units in your answers.

A)

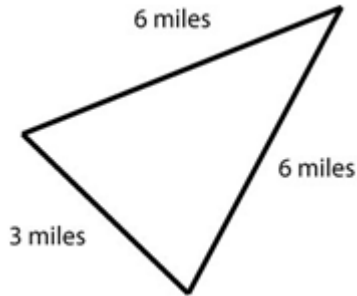

B)

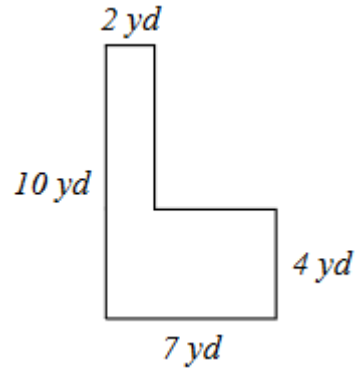
**Section 1.3 – Area**

The area of a *two-dimensional* figure describes the amount of surface the shape covers. You measure area in square units of a fixed size. Examples of square units of measure are square inches, square centimeters, or square miles. When finding the area of a polygon, you count how many squares of a certain size will cover the region inside the polygon.

Example 3

Find the area of the rectangle below.

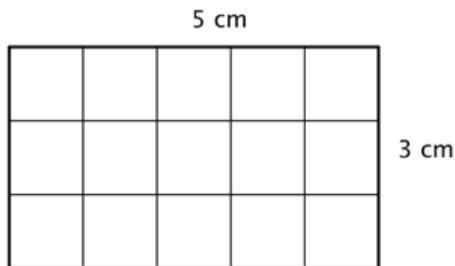

You can count the squares individually, but it is much easier to multiply 3 times 5 to find the number more quickly. And, more generally, the area of any rectangle can be found by multiplying *length* times *width*.

So the area of the rectangle with length 5cm and width 3cm would be

$$5\text{cm} \cdot 3\text{cm} = 15\text{cm}^2.$$

To help you find the area of the many different categories of polygons, mathematicians have developed formulas. These formulas help you find the measurement more quickly than by simply counting. The formulas you are going to look at are all developed from the understanding that you are counting the number of square units *inside* the polygon.

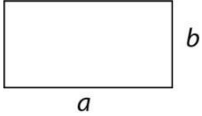
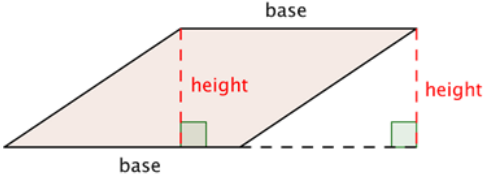
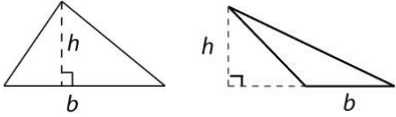
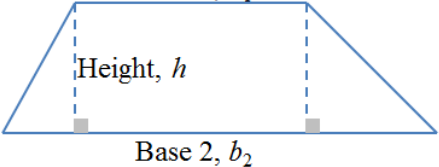
Shape	Area
<p>Rectangle with side lengths a, b</p> 	$A = a \times b$
<p>Parallelogram with height h and base b</p> 	$A = b \cdot h$
<p>Triangle with height h and base b</p> 	$A = \frac{1}{2}bh = \frac{bh}{2}$
<p>Trapezoid as shown below</p> 	$A = \frac{b_1 + b_2}{2} h$

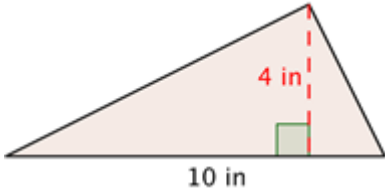
Example 4	
A triangle has a height of 4 inches and a base of 10 inches. Find the area.	
	$A = \frac{1}{2}bh$ <p>Start with the formula for the area of a triangle.</p> $A = \frac{1}{2}(10)(4)$ <p>Substitute 10 for the base and 4 for the height.</p> $A = 20 \text{ in}^2$

Example 5

Find the area and perimeter of the trapezoid shown below.

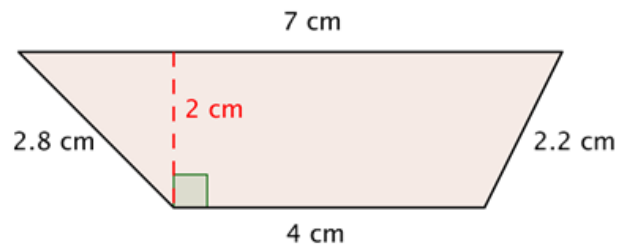
**AREA**

$$A = \frac{b_1 + b_2}{2} h$$

Start with the formula for the area of a trapezoid.

$$A = \frac{4 + 7}{2} \cdot 2$$

Substitute 4 and 7 for the bases and 2 for the height, and find A.

$$A = \frac{11}{2} \cdot 2$$

$$A = 11$$

The area of the trapezoid is 11 cm^2 .

PERIMETER

Remember that perimeter is the distance around a closed shape.

$$P = 7 \text{ cm} + 2.2 \text{ cm} + 4 \text{ cm} + 2.8 \text{ cm} = 16 \text{ cm}$$

You Try 1.3

Find the perimeter and area of the parallelogram shown below.

Be sure to use correct units in your answers.

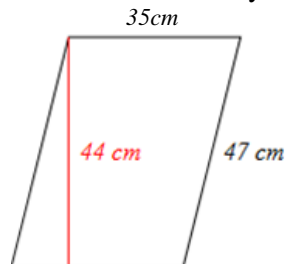
**Section 1.4 – The Pythagorean Theorem**

A long time ago, a Greek mathematician named **Pythagoras** discovered an interesting property about **right triangles** (triangles with a 90 degree angle). He discovered that the sum of the squares of the lengths of each of the triangle's **legs** is the same as the square of the length of the triangle's **hypotenuse**. This property—which has many applications in science, art, engineering, and architecture—is now called the **Pythagorean Theorem**.

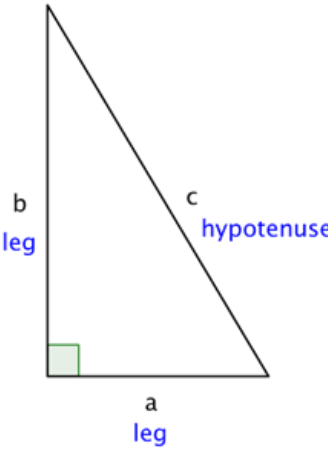

The Pythagorean Theorem

If a and b are the lengths of the legs of a right triangle and c is the length of the hypotenuse, then the sum of the squares of the lengths of the legs is equal to the square of the length of the hypotenuse.

This relationship is represented by the formula:

$$a^2 + b^2 = c^2$$

In the box above, you may have noticed the word “square,” as well as the small 2s to the top right of the letters in $a^2 + b^2 = c^2$. To **square** a number means to multiply it by itself. So, for example, to square the number 5 you multiply $5 \cdot 5$, and to square the number 12, you multiply $12 \cdot 12$.

When you see the equation $a^2 + b^2 = c^2$, you can think of this as “the length of side a times itself, plus the length of side b times itself is the same as the length of side c times itself.”

Let’s try out the Pythagorean Theorem with an actual right triangle.

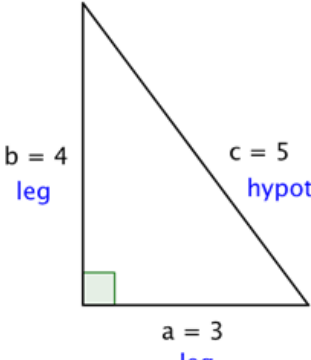

$a^2 + b^2 = c^2$
 $(3)^2 + (4)^2 = (5)^2$
 $9 + 16 = 25$

This theorem holds true for this right triangle—the sum of the squares of the lengths of both legs is the same as the square of the length of the hypotenuse. And, in fact, it holds true for all right triangles.

Note that the Pythagorean Theorem only works with *right* triangles.

You Try 1.4A

For which of these triangles is $(3)^2 + (3)^2 = r^2$? Select all that apply.

A)

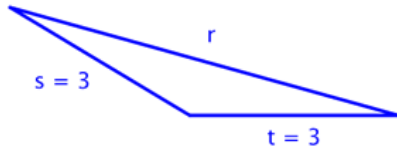

B)

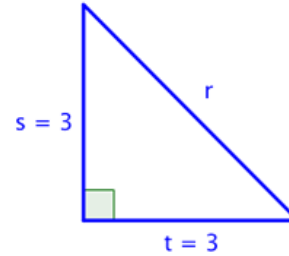

C)

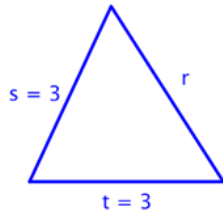

D)

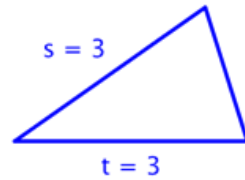

Finding the Length of the Hypotenuse

You can use the Pythagorean Theorem to find the length of the hypotenuse of a right triangle if you know the length of the triangle's other two sides, called the legs. Put another way, if you know the lengths of a and b , you can find c .

Example 6

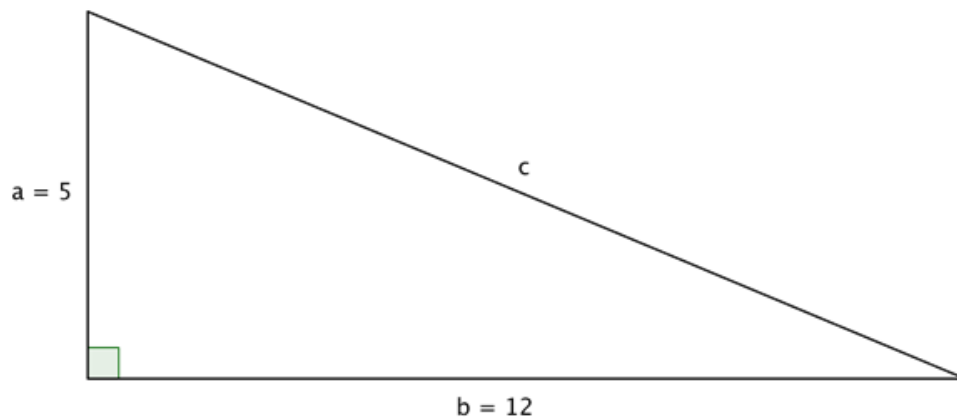

In the triangle above, you are given measures for legs a and b : 5 and 12, both in inches. Use the Pythagorean Theorem to find a value for the length of c , the hypotenuse. Then use your answer to find the perimeter of the triangle.

$$a^2 + b^2 = c^2$$

The Pythagorean Theorem.

$$(5)^2 + (12)^2 = c^2$$

Substitute known values for a and b .

$$25 + 144 = c^2$$

Evaluate.

$$169 = c^2$$

Simplify by taking the square root.

$$13 = c$$

The square root of 169 is 13.

Using the formula, you find that the length of c , the hypotenuse, is 13 inches.

You can then find the perimeter of the triangle by adding the length of all three sides.

$$\text{Perimeter} = 5 \text{ inches} + 12 \text{ inches} + 13 \text{ inches} = 30 \text{ inches}$$

Finding the Length of a Leg

You can use the same formula to find the length of a right triangle's leg if you are given measurements for the lengths of the hypotenuse and the other leg. Consider the example below.

Example 7

Find the length of side a in the triangle below, the perimeter of the triangle, and the area of the triangle. Assume all units are in centimeters.

Write your answer in **exact** form and in **approximate** form, rounded to the nearest thousandth.

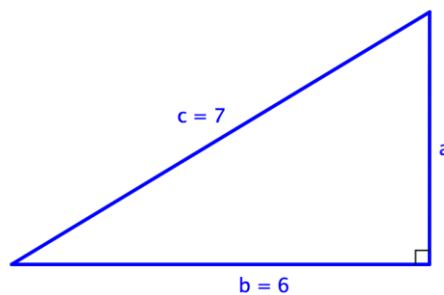

$$a = ?$$

$$b = 6$$

$$c = 7$$

In this right triangle, you are given the measurements for the hypotenuse, c , and one leg, b . The hypotenuse is always opposite the right angle and it is always the longest side of the triangle.

$$a^2 + b^2 = c^2$$

$$a^2 + 6^2 = 7^2$$

To find the length of leg a , substitute the known values into the Pythagorean Theorem.

$$a^2 + 36 = 49$$

$$a^2 = 13$$

$$a = \sqrt{13}$$

Solve for a^2 .

Answer: Exact form: $a = \sqrt{13}$

Approximate form: $a \approx 3.606$

To find the **perimeter**, add up the lengths of all sides of the triangle.

$$P = a + b + c$$

$$P \approx 3.606\text{cm} + 6\text{cm} + 7\text{cm}$$

$$P \approx 16.606 \text{ cm}$$

Now that we know the height, we can use it to find the **area** of the triangle.

$$A = \frac{1}{2}bh$$

$$A \approx \frac{1}{2}(6 \cdot 3.606)$$

$$A \approx 10.818 \text{ cm}^2$$

You Try 1.4B

Find the length of side x in the triangle below, and the perimeter of the triangle. Assume all units are in centimeters. Write your answer in **exact** form and in **approximate** form, rounded to the nearest thousandth.

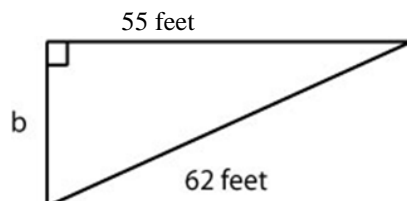

Using the Theorem to Solve Real World Problems

The Pythagorean Theorem is perhaps one of the most useful formulas you will learn in mathematics because there are so many applications of it in real world settings. Architects and engineers use this formula when building ramps, bridges, and buildings. Consider the following:

Example 8

The owners of a house want to convert a stairway leading from the ground to their back porch into a ramp. The porch is 3 feet off the ground, and due to building regulations the ramp must start 12 feet away from the base of the porch. How long will the ramp be? Round your answer to the nearest tenth.

To solve a problem like this one, it often makes sense to draw a simple diagram showing where the legs and hypotenuse of the triangle lie.

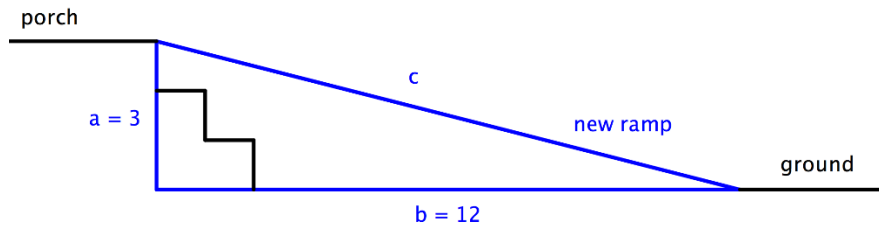

$$\begin{aligned} a &= 3 \\ b &= 12 \\ c &= ? \end{aligned}$$

Identify the legs and the hypotenuse of the triangle. You know that the triangle is a *right* triangle since the ground and the raised portion of the porch are perpendicular—this means you can use the Pythagorean Theorem to solve this problem. Identify a , b , and c .

$$\begin{aligned} a^2 + b^2 &= c^2 \\ (3)^2 + (12)^2 &= c^2 \\ 153 &= c^2 \\ \sqrt{153} &= c \\ 12.4 &\approx c \end{aligned}$$

Use the Pythagorean Theorem to find the length of c .

Use a calculator to find c . The square root of 153 is 12.369..., so you can round that to 12.4.

The ramp will be 12.4 feet long.

Example 9

A sailboat has a large sail in the shape of a right triangle. The longest edge of the sail measures 17 yards, and the bottom edge of the sail is 8 yards. How tall is the sail?

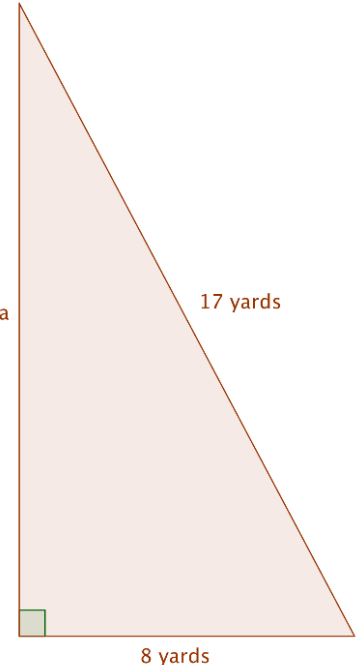

Draw an image to help you visualize the problem.

In a right triangle, the hypotenuse will always be the longest side, so here it must be 17 yards.

The problem also tells you that the bottom edge of the triangle is 8 yards.

Set up the Pythagorean Theorem: $a^2 + b^2 = c^2$

$$a^2 + (8)^2 = (17)^2$$

$$a^2 + 64 = 289$$

$$a^2 = 225$$

$$a = \sqrt{225}$$

$$a = 15$$

The height of the sail is 15 yards.

You Try 1.4C

You've decided to complete a "do it yourself" project and retile your bathroom floor. The tiles that you picked out are 12 inches by 12 inches. To make the pattern more interesting, you decide to cut the tiles in half along the diagonal, then place the cut edge of the tile along the wall (see the picture below). About how many $\frac{1}{2}$ tiles will you need to make the first row, if the wall is 170 inches long?

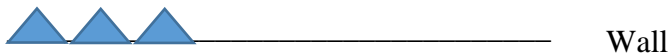

Section 1.5 – Circles

Circles are a common shape. You see them all over—wheels on a car, Frisbees passing through the air, DVD's bringing you entertainment. These are all circles.

A circle is a two-dimensional figure just like polygons and quadrilaterals. However, circles are measured differently than these other shapes—you even have to use some different terms to describe them. Let's take a look at this interesting shape.

Properties of Circles

A circle represents a set of points, all of which are the same distance away from a fixed, middle point. This fixed point is called the center. The distance from the center of the circle to any point on the circle is called the **radius**. When two radii (the plural of

radius) are put together to form a line segment across the circle, you have a **diameter**. The diameter of a circle passes through the center of the circle and has its endpoints on the circle itself.

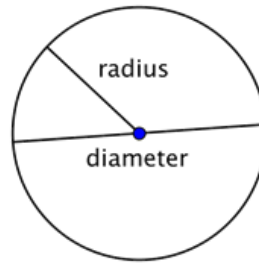

The diameter of any circle is two times the length of that circle's radius. It can be represented by the expression $2r$, or "two times the radius." So if you know a circle's radius, you can multiply it by 2 to find the diameter; this also means that if you know a circle's diameter, you can divide by 2 to find the radius.

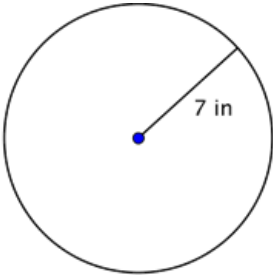
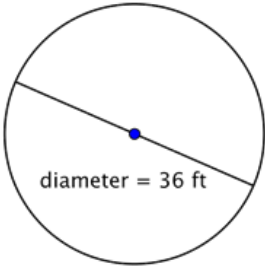
Example 10	
<p>Find the diameter of the circle.</p>  <p>The diameter is two times the radius, or $2r$. The radius of this circle is 7 inches, so the diameter is $2(7) = 14$ inches.</p>	<p>Find the radius of the circle.</p>  <p>The radius is half the diameter, or $\frac{1}{2}d$. The diameter of this circle is 36 feet, so the radius is $\frac{1}{2}(36) = 18$ feet.</p>

Circumference

The distance around a circle is called the **circumference**. (Recall, the distance around a polygon is the perimeter.) One interesting property about circles is that the ratio of a circle's circumference and its diameter is the same for all circles. No matter the size of the circle, the ratio of the circumference and diameter will be the same.

Some actual measurements of different items are provided below. The measurements are accurate to the nearest millimeter or quarter inch (depending on the unit of measurement used). Look at the ratio of the circumference to the diameter for each one—although the items are different, the ratio for each is approximately the same.

Item	Circumference (C) (rounded to nearest hundredth)	Diameter (d)	Ratio $\frac{C}{d}$
Cup	253 mm	79 mm	$\frac{253}{79} = 3.2025 \dots$
Quarter	84 mm	27 mm	$\frac{84}{27} = 3.1111 \dots$
Bowl	37.25 in	11.75 in	$\frac{37.25}{11.75} = 3.1702 \dots$

The circumference and the diameter are approximate measurements, since there is no precise way to measure these dimensions exactly. If you were able to measure them more precisely, however, you would find that the ratio $\frac{C}{d}$ would move towards 3.14 for each of the items given. The mathematical name for this ratio is **pi**, and is represented by the Greek letter π .

Pi is a non-terminating, non-repeating decimal, so it is impossible to write it out completely. The first 10 digits of π are 3.141592653; it is often rounded to 3.14 or estimated as the fraction $\frac{22}{7}$. Note that both 3.14 and $\frac{22}{7}$ are *approximations* of π , and are used in calculations where it is not important to be precise.

Since you know that the ratio of circumference to diameter (or π) is consistent for all circles, you can use this number to find the circumference of a circle if you know its diameter.

$$\frac{C}{d} = \pi, \text{ so } C = \pi d$$

Also, since $d = 2r$, then $C = \pi d = \pi(2r) = 2\pi r$.

Circumference of a Circle

To find the circumference (C) of a circle, use one of the following formulas:

If you know the diameter (d) of a circle: $C = \pi d$

If you know the radius (r) of a circle: $C = 2\pi r$

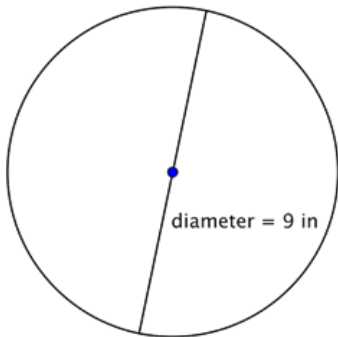
Example 11**Find the circumference.**

$$C = \pi d$$

$$C = \pi(9)$$

$$C \approx 3.14(9)$$

$$C \approx 28.26$$

Exact: 9π
 Approximate: 28.26

To calculate the circumference given a diameter of 9 inches, use the formula $C = \pi d$. Use 3.14 as an approximation for π .

Since you are using an approximation for π , you cannot give an exact measurement of the circumference. Instead, you use the symbol \approx to indicate "approximately equal to."

The circumference is 9π , or approximately 28.26 inches.

Area of a Circle

To find the area (A) of a circle, use the formula: $A = \pi r^2$

Where r is the radius of the circle.

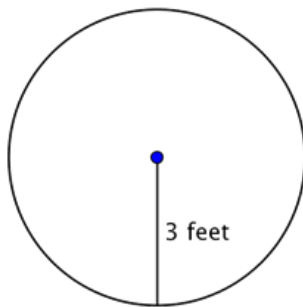
Example 12**Find the area of the circle.**

$$A = \pi r^2$$

$$A = \pi(3)^2$$

$$A = \pi(9)$$

$$A \approx 3.14(9)$$

$$A \approx 28.26$$

To find the area of this circle, use the formula $A = \pi r^2$.

Remember to write the answer in terms of square units, since you are finding the area.

The area is 9π or approximately 28.26 feet².

Exact: $9\pi \text{ ft}^2$ Approximate: 28.26 ft²

You Try 1.5

A circle has a radius of 8 inches. Determine its area and circumference. Write your answers in **exact** form and in **approximate** form, rounded to the nearest tenth. Be sure to include correct units in your answers.

Section 1.6 – Perimeter and Area of Composite Figures

Often you need to find the area or perimeter of a shape that is not a standard polygon. Artists and architects, for example, usually deal with complex shapes. However, even complex shapes can be thought of as being composed of smaller, less complicated shapes, like rectangles, trapezoids, and triangles.

To find the perimeter of non-standard shapes, you still find the distance around the shape by adding together the length of each side. Finding the area of non-standard shapes is a bit different. You need to create regions *within* the shape for which you can find the area, and add these areas together. Have a look at how this is done below.

Example 13

Find the perimeter and area of the polygon.

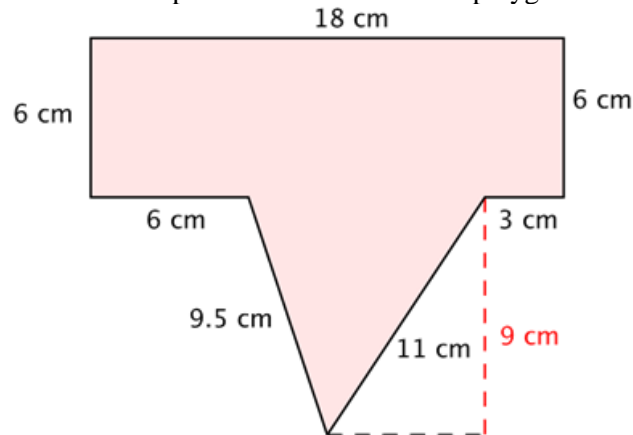

PERIMETER

$$P = 18 + 6 + 3 + 11 + 9.5 + 6 + 6$$

$$P = 59.5 \text{ cm}$$

To find the perimeter, add together the lengths of the sides. Start at the top and work clockwise around the shape.

The perimeter of this shape is 59.5cm.

AREA

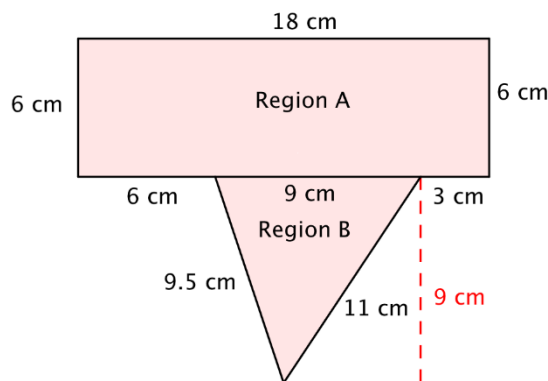

To find the area, divide the polygon into two separate, simpler regions. The area of the entire polygon will equal the sum of the areas of the two regions.

$$\text{Area of Polygon} = (\text{Area of A}) + (\text{Area of B})$$

Region A is a rectangle. To find the area, multiply the length (18) by the width (6).

$$A = L \cdot W = 18 \cdot 6 = 108$$

The area of Region A is 108 cm².

Region B is a triangle. To find the area, use the formula $\frac{1}{2}bh$, where the base is 9 and the height is 9.

$$A = \frac{1}{2}bh = \frac{1}{2}(9)(9) = 40.5$$

The area of Region B is 40.5 cm².

Add the regions together to find the total area: $108 \text{ cm}^2 + 40.5 \text{ cm}^2 = 148.5 \text{ cm}^2$

You also can use what you know about perimeter and area to help solve problems about situations like buying fencing or paint, or determining how big a rug is needed in the living room. Here's a fencing example.

Example 14

Rosie is planting a garden with the dimensions shown below. She wants to put a thin, even layer of mulch over the entire surface of the garden. The mulch costs \$3 a square foot. How much money will she have to spend on mulch?

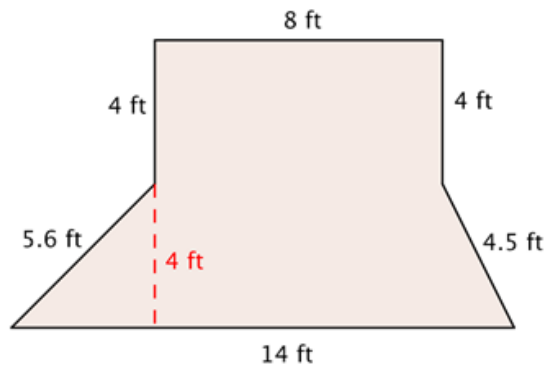

This shape is a combination of two simpler shapes: a rectangle and a trapezoid.

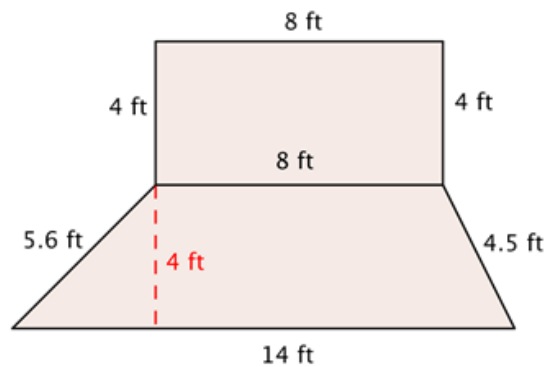

<p>Find the area of the trapezoid.</p> $A = \frac{b_1 + b_2}{2} h$ $A = \frac{14 + 8}{2} \cdot 4$ $A = \frac{22}{2} \cdot 4$ $A = 44 \text{ ft}^2$	<p>Find the area of the rectangle.</p> $A = L \cdot W$ $A = 8 \cdot 4$ $A = 32 \text{ ft}^2$
<p>Add the measurements. $32 \text{ ft}^2 + 44 \text{ ft}^2 = 76 \text{ ft}^2$</p> <p>Multiply by \$3 to find out how much Rosie will have to spend. $76 \text{ ft}^2 \cdot \\$3 = \\228</p> <p style="text-align: center;">Rosie will spend \$228 to cover her garden with mulch.</p>	

You Try 1.6A

Find the perimeter and area of the shape shown below. Be sure to use correct units in your answer.

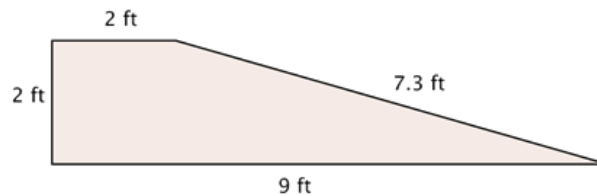

Since you also know how to calculate the circumference and area of a circle, you can use this knowledge to find the perimeter and area of composite figures that include circles and semi-circles. The trick to figuring out these types of problems is to identify shapes (and parts of shapes) within the composite figure, calculate their individual dimensions, and then add them together. For example, look at the image below. Is it possible to find the perimeter?

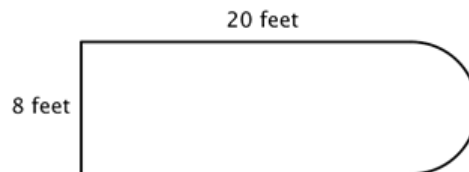

The first step is to identify simpler figures within this composite figure. You can break it down into a rectangle and a semicircle, as shown below.

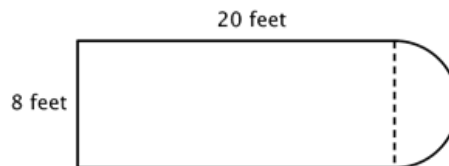

You know how to find the perimeter of a rectangle, and you know how to find the circumference of a circle. Here, the perimeter of the three solid sides of the rectangle is

$8 + 20 + 20 = 48$ feet. (Note that only three sides of the rectangle will add into the perimeter of the composite figure because the other side is not at an edge; it is covered by the semicircle!)

To find the circumference of the semicircle, use the formula $C = \pi d$ with a diameter of 8 feet, then take half of the result. The circumference of the semicircle is 4π , or approximately 12.56 feet.

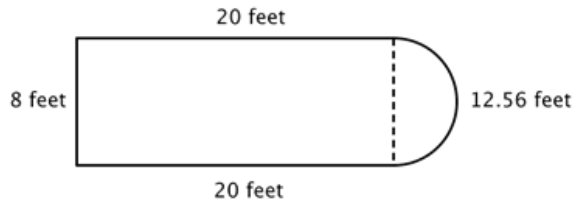

Adding up the sides, we find that the total perimeter is about 60.56 feet.

Example 15

Find the perimeter (to the nearest hundredth) of the composite figure, made up of a semi-circle and a triangle.

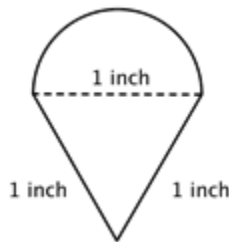

Identify smaller shapes within the composite figure.

This figure contains a semicircle and a triangle. Since we are looking for the perimeter, we need to first find the circumference of the semicircle.

Find the circumference of the circle. Then divide by 2 to find the circumference of the semi-circle.

$$\text{Diameter } (d) = 1$$

$$C = \pi d$$

$$C = \pi(1)$$

$$C = \pi$$

$$\text{Circumference of semicircle} = \frac{1}{2}\pi \text{ or approximately } 1.57 \text{ inches}$$

Find the total perimeter by adding the circumference of the semicircle and the lengths of the two legs. Since our measurement of the semi-circle's circumference is approximate, the perimeter will be an approximation also.

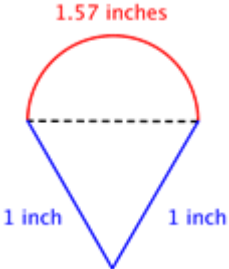

Perimeter = $1 + 1 + \frac{1}{2}\pi \approx 3.57$ inches

The perimeter is approximately 3.57 inches

Example 16

Find the area of the composite figure, made up of three-quarters of a circle and a square, to the nearest hundredth.

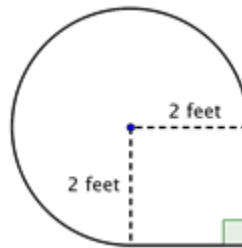

Identify smaller shapes within the composite figure. This figure contains a circular region and a square. If you find the area of each, you can find the area of the entire figure.

Find the area of the square.

$$A = s^2$$

$$A = (2)^2$$

$$A = 4 \text{ ft}^2$$

Find the area of the circular region.

The radius is 2 feet. Note that the region is $\frac{3}{4}$ of a whole circle, so you need to multiply the area of the circle by $\frac{3}{4}$.

Area of full circle: $A = \pi r^2$

$$A = \pi(2)^2$$

$$A = 4\pi \text{ ft}^2$$

Area of $\frac{3}{4}$ of full circle: $\frac{3}{4}(4\pi) = 3\pi$ This is approximately 9.42 ft^2

Add the two regions together. Since your measurement of the circular's area is approximate, the area of the figure will be an approximation also.

$4 \text{ feet}^2 + 3\pi \text{ feet}^2 = \text{approximately } 13.42 \text{ feet}^2$

The total area is approximately 13.42 feet^2 .

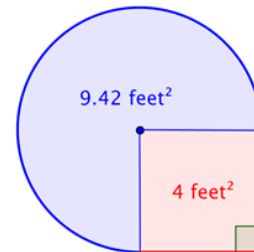

You Try 1.6B

Find the perimeter and area of the shape shown below. Be sure to use correct units in your answers. Round your answers to the nearest hundredth as needed. Be sure to include correct units in your answers. (Both rounded regions are semi-circles.)

Section 1.7 – Working in Three Dimensions: Volume

Living in a two-dimensional world would be pretty boring. Thankfully, all of the physical objects that you see and use every day—computers, phones, cars, shoes—exist in *three dimensions*. They all have length, width, and height. (Even very thin objects like a piece of paper are three-dimensional. The thickness of a piece of paper may be a fraction of a millimeter, but it exists.)

In the world of geometry, it is common to see three-dimensional figures. In mathematics, a flat side of a three-dimensional figure is called a **face**. **Polyhedrons** are shapes that have four or more faces, each one being a polygon. These include cubes, prisms, and pyramids. Sometimes you may even see single figures that are composites of two of these figures. Let’s take a look at some common polyhedrons.

Identifying Solids

The first set of solids contains rectangular bases. Have a look at the table below, which shows each figure in both solid and transparent form.

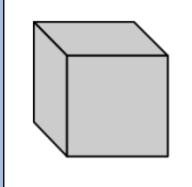
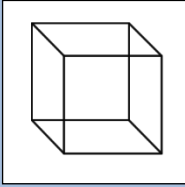
Name	Definition	Solid Form	Transparent Form
Cube	A six-sided polyhedron that has congruent squares as faces.		

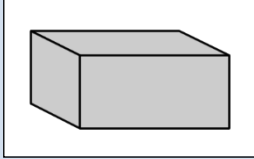
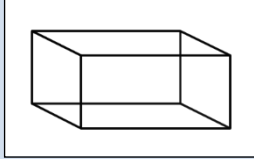
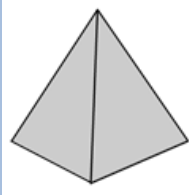
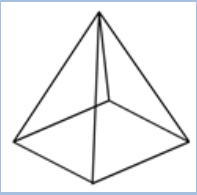
<p>Rectangular prism</p>	<p>A polyhedron that has three pairs of congruent, rectangular, parallel faces.</p>		
<p>Pyramid</p>	<p>A polyhedron with a polygonal base and a collection of triangular faces that meet at a point.</p>		

Notice the different names that are used for these figures. A **cube** is different than a square, although they are sometimes confused with each other—a cube has three dimensions, while a square only has two. Likewise, you would describe a shoebox as a **rectangular prism** (not simply a rectangle), and the ancient **pyramids** of Egypt as...well, as pyramids (not triangles)!

In this next set of solids, each figure has a circular base.

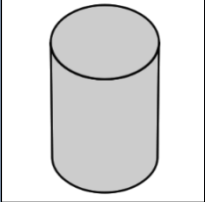
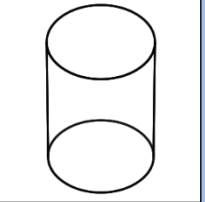
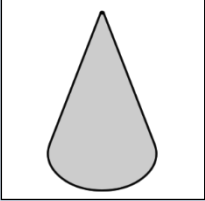
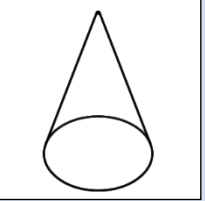
Name	Definition	Solid Form	Transparent Form
<p>Cylinder</p>	<p>A solid figure with a pair of circular, parallel bases and a round, smooth face between them.</p>		
<p>Cone</p>	<p>A solid figure with a single circular base and a round, smooth face that diminishes to a single point.</p>		

Take a moment to compare a pyramid and a **cone**. Notice that a pyramid has a rectangular base and flat, triangular faces; a cone has a circular base and a smooth, rounded body.

Finally, let's look at a shape that is unique: a **sphere**. There are many spherical objects all around you—soccer balls, tennis balls, and baseballs being three common items.

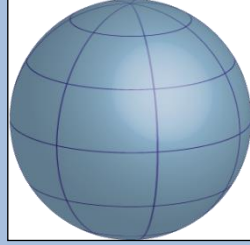
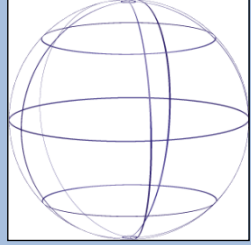
Name	Definition	Solid Form	Transparent Form
Sphere	A solid, round figure where every point on the surface is the same distance from the center.		

Volume

Recall that perimeter measures one dimension (length), and area measures two dimensions (length and width). To measure the amount of space a three-dimensional figure takes up, you use another measurement called **volume**.

To visualize what “volume” measures, look back at the transparent image of the rectangular prism mentioned earlier (or just think of an empty shoebox). Imagine stacking identical cubes inside that box so that there are no gaps between any of the cubes. Imagine filling up the entire box in this manner. If you counted the number of cubes that fit inside that rectangular prism, you would have its volume.

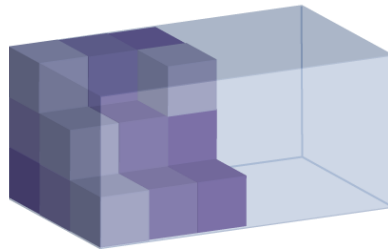

Volume is measured in cubic units. The shoebox illustrated above may be measured in cubic inches (usually represented as in^3 or inches^3), while the Great Pyramid of Egypt would be more appropriately measured in cubic meters (m^3 or meters^3).

To find the volume of a geometric solid, you could create a transparent version of the solid, create a bunch of $1 \times 1 \times 1$ cubes, and then stack them carefully inside. However, that would take a long time! A much easier way to find the volume is to become familiar with some geometric formulas, and to use those instead.

As you look through the list below, you may notice that some of the volume formulas look similar to their area formulas. To find the volume of a rectangular prism, you find the area of the base and then multiply that by the height.

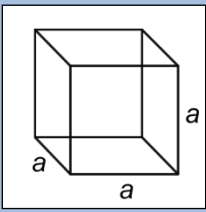
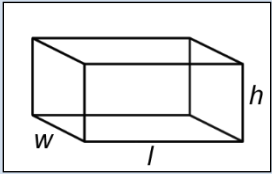
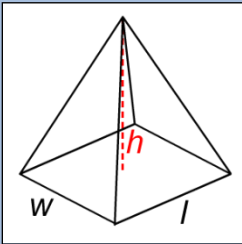
Name	Transparent Form	Volume Formula
Cube		$V = a \cdot a \cdot a = a^3$ $a =$ the length of one side
Rectangular prism		$V = l \cdot w \cdot h$ $l =$ length $w =$ width $h =$ height
Pyramid		$V = \frac{l \cdot w \cdot h}{3}$ $l =$ length $w =$ width $h =$ height

Remember that all cubes are rectangular prisms, so the formula for finding the volume of a cube is the area of the base of the cube times the height.

Now let's look at solids that have a circular base.

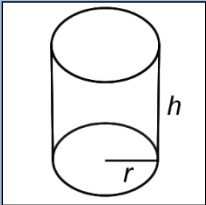
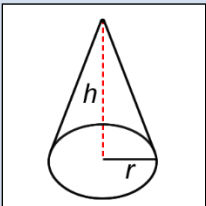
Name	Transparent Form	Volume Formula
Cylinder		$V = \pi r^2 h$ $r =$ radius $h =$ height
Cone		$V = \frac{\pi r^2 h}{3}$ $r =$ radius $h =$ height

Looking for patterns and similarities in the formulas can help you remember which formula refers to a given solid.

- The volume of a **cylinder** is the area of its base, πr^2 , times its height, h .
- Compare the formula for the volume of a cone, $V = \frac{\pi r^2 h}{3}$, with the formula for the volume of a pyramid, $V = \frac{l \cdot w \cdot h}{3}$. The numerator of the cone formula is the volume formula for a cylinder, and the numerator of the pyramid formula is the volume formula for a rectangular prism. Then divide each by 3 to find the volume of the cone and the pyramid.

Finally, the formula for a sphere is provided below. Notice that the radius is cubed, not squared and that the quantity πr^3 is multiplied by $\frac{4}{3}$.

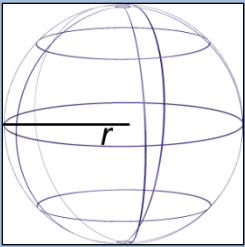
Name	Wireframe Form	Volume Formula
Sphere		$V = \frac{4}{3} \pi r^3$ <p>$r = \text{radius}$</p>

Applying the Formulas

You know how to identify the solids, and you also know the volume formulas for these solids. To calculate the actual volume of a given shape, all you need to do is substitute the solid's dimensions into the formula and calculate. In the examples below, notice that **cubic units** (meters³, inches³, feet³) are used.

Example 17

Find the volume of the shape shown below.

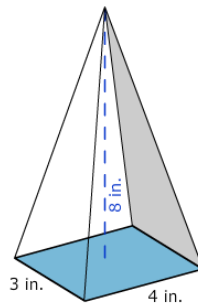

Identify the shape. It has a rectangular base and rises to a point, so it is a pyramid.

Identify the proper formula to use.

$$V = \frac{l \cdot w \cdot h}{3}$$

l = length, w = width, h = height

Use the image to identify the dimensions.

length = 4, width = 3, height = 8

Then substitute $l = 4$, $w = 3$, and $h = 8$ into the formula and calculate the volume.

$$V = \frac{4 \cdot 3 \cdot 8}{3} = \frac{96}{3} = 32$$

The volume of the pyramid is 32 inches³.

Example 18

Find the volume of the shape shown below. Write your answer in exact form and approximate form, rounded to the nearest hundredth.



Identify the shape. It has a circular base and has uniform thickness (or height), so it is a cylinder. Identify the proper formula to use. $V = \pi r^2 h$

Use the image to identify the dimensions.

$$V = \pi(7)^2(1)$$

Then substitute $r = 7$ and $h = 1$ into the formula and calculate the volume.

$$V = \pi \cdot 49 \cdot 1$$

$$V = 49\pi$$

$$V \approx 153.86$$

The volume is 49π or approximately 153.86 feet³.

You Try 1.7

Determine the volume of a sphere with radius 6 feet. Write your answer in **exact** form and in **approximate** form, rounded to the nearest hundredth. Be sure to include correct units in your answer.

Chapter 1 – Answers to You Try Problems

1.2 a) 15 miles b) 34 yards

1.3. Perimeter = 164cm Area = 2024cm²

1.4A. B, because it is a right triangle.

- 1.4B. Exact: $\sqrt{819}$ cm Approximate: 28.618 cm
- 1.4C. You will need about 10 of the $\frac{1}{2}$ tiles.
- 1.5. The area is 64π or approximately 201.1 in².
The circumference is 16π or approximately 50.3 inches.
- 1.6A. Perimeter = 20.3 feet Area = 11 square feet
- 1.6B. Perimeter = 10.28 in Area = 7.14 in²
- 1.7. Exact: 288π ft Approximate: 904.78 ft²

Chapter 1 - Practice Problems

1. Find the perimeter of the rectangle shown below.

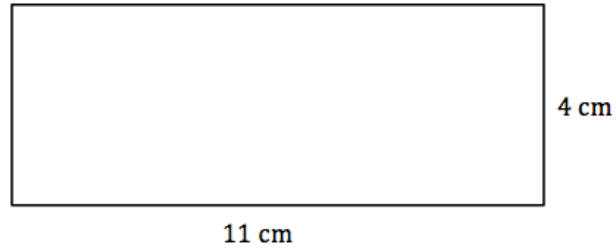

2. Find the perimeter of the triangle shown below.

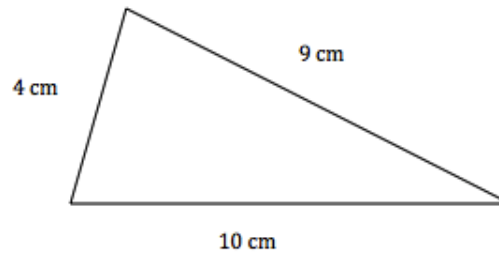

3. Find the perimeter of the parallelogram shown below

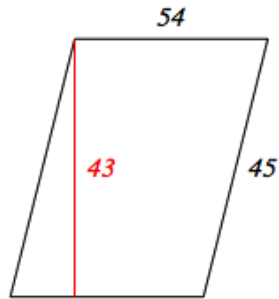

4. Find the perimeter of the trapezoid shown below

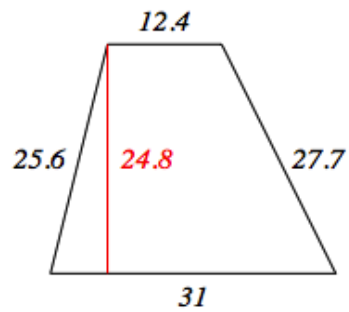

5. Find the perimeter of the figure pictured below.

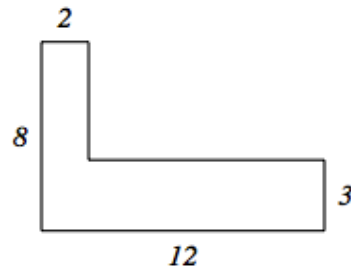

6. Find the area of the triangle pictured below

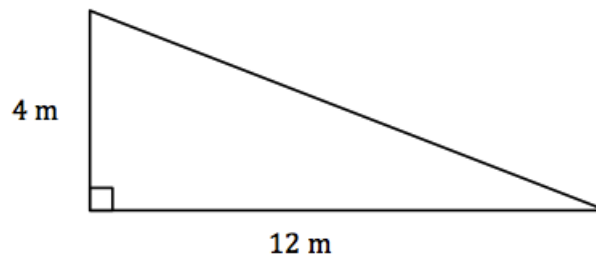

7. Find the area of the triangle shown below.

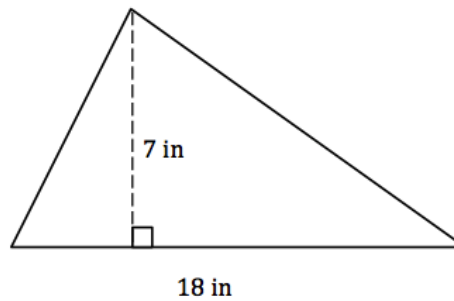

8. Find the area and perimeter of the trapezoid shown below.

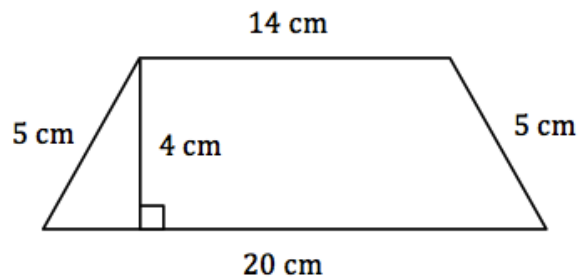

9. Find the area and perimeter of the parallelogram shown below

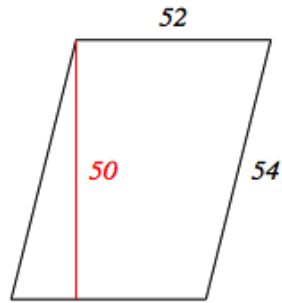

10. Find the length of the hypotenuse of the triangle pictured below. Write your answer in **exact** form and in **approximate** form, rounded to the nearest thousandth.

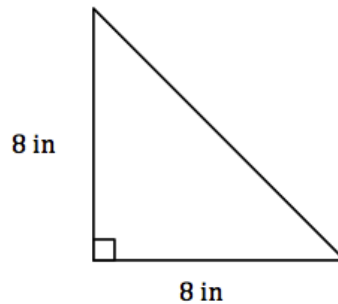

11. Find the length of the hypotenuse of the triangle pictured below. Write your answer in **exact** form and in **approximate** form, rounded to the nearest thousandth.

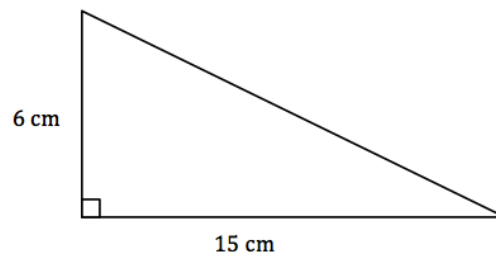

12. Find the length of the leg a . Write your answer in **exact** form and in **approximate** form, rounded to the nearest thousandth.

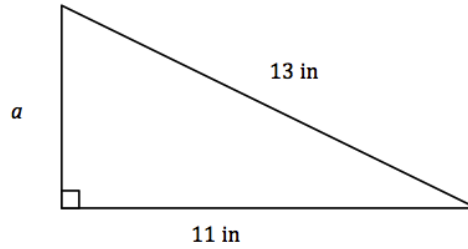

13. Find the length of the leg b . Write your answer in **exact** form and in **approximate** form, rounded to the nearest thousandth.

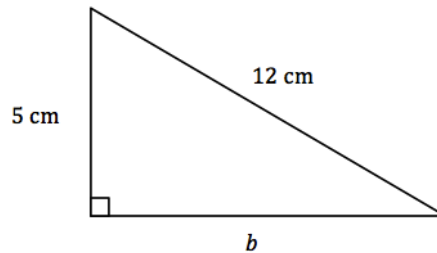

14. Laptop computers are measured according to the diagonals of their screens. An 18-inch laptop has a screen that is 9 inches tall. Round all answers to the nearest hundredth.
- How wide is the screen?
 - What is the area of the screen?
15. A cable is installed around two edges of the rectangular field that is 860 feet long and 340 feet wide, as shown below. Suppose the cable costs \$2100 per foot to install. Round all answers to the nearest hundredth.
- How much did it cost to run the cable along the two edges of the field?
 - How much would it have cost to run the cable along the diagonal?
 - How much money would have been saved if the cable were installed along the diagonal of the field instead of around the edges of the field?

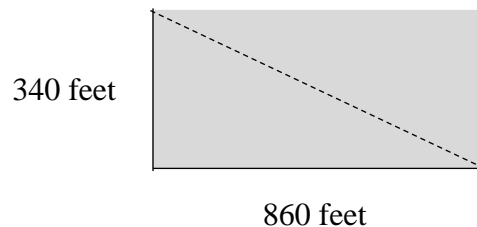

16. Two trains leave the station at the same time. Train A travels south at a rate of 25 miles per hour south and train B travels east at a rate of 20 miles per hour. How far apart are the trains 6 hours after they leave the station? Round your answer to the nearest tenth.

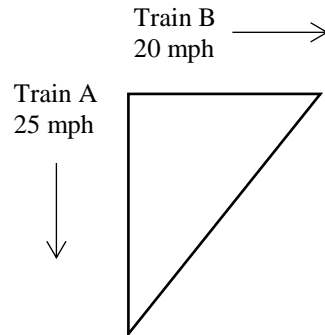

17. Find the diameter of the circle shown below.

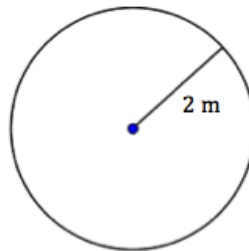

18. Find the radius of the circle shown below.

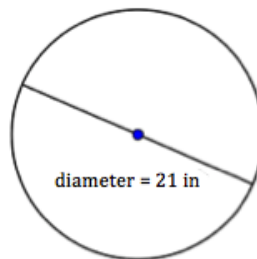

19. Find the circumference and area of the circle shown below. Round your answers to the nearest hundredth.

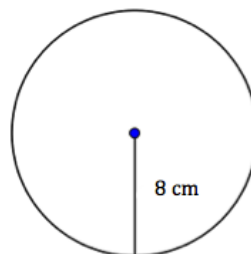

20. Find the circumference and area of the circle pictured below. Round your answers to the nearest hundredth.

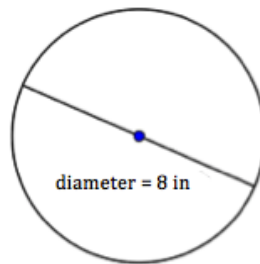

21. Find the area of the circle shown below. Write your answer in **exact** form and in **approximate** form, rounded to the nearest tenth.

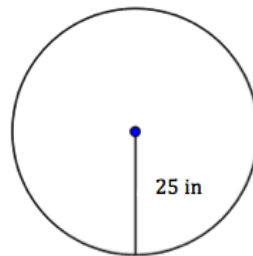

22. Find the circumference and area of the circle shown below. Write your answers in **exact** form and in **approximate** form, rounded to the nearest tenth.

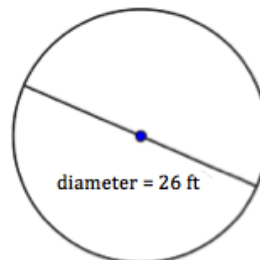

23. Find the area and perimeter of the figure shown below.

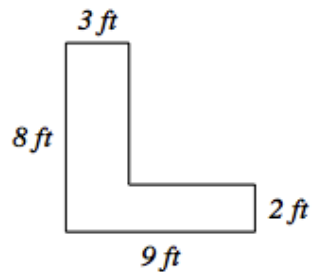

24. Find the perimeter and area of the polygon shown below.

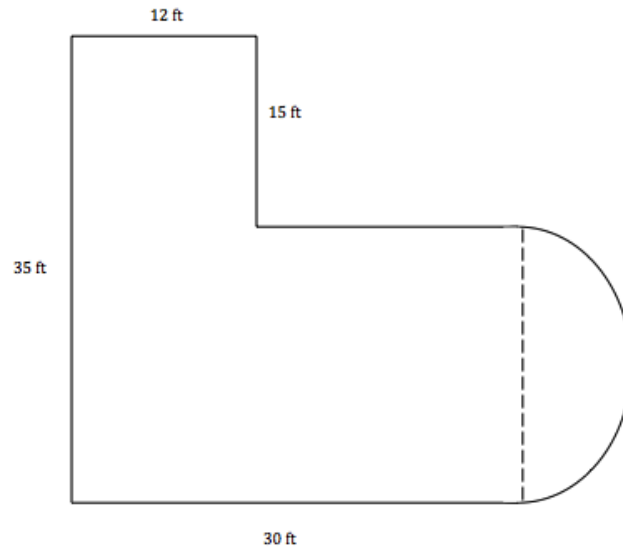

25. Find the perimeter and area of the polygon shown below.

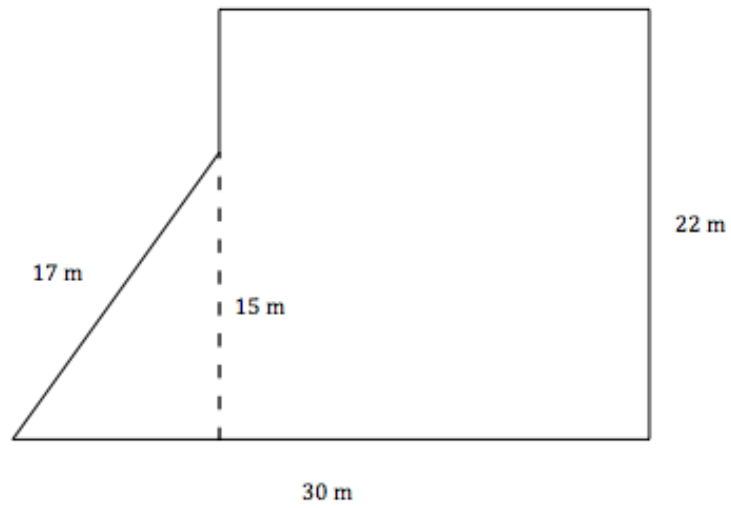

26. Find the area and perimeter of the shape below.

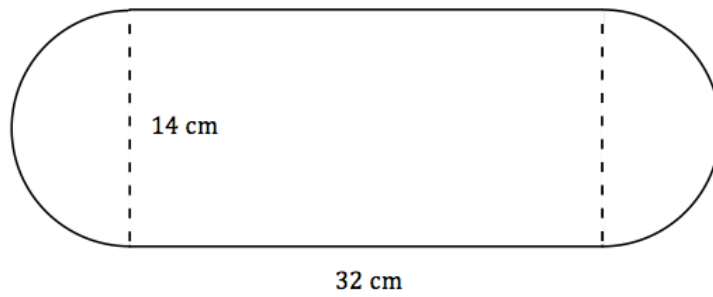

27. Find the volume of the shape shown below.

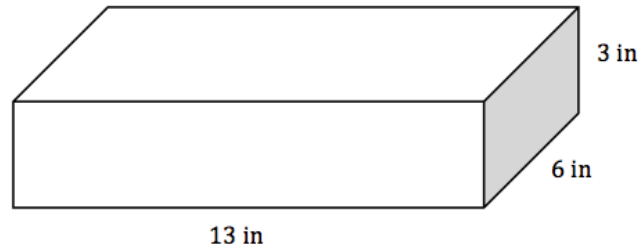

28. Sketch a cylinder with radius of 10 feet and height of 4 feet. Find the volume (round to the nearest tenth).
29. Sketch a cone with radius of 7 feet and height of 8 feet. Find the volume (round to the nearest tenth).
30. If a rectangular garden is 20 feet by 40 feet, how many feet of fencing is needed to enclose it?
31. You need to paint the trim of a window on the exterior of a house. The window is 12 feet above the ground and your ladder is 16 feet long. How far is the base of the ladder from the side of the house? Round your answer to the nearest tenth.
32. How many square feet of carpet are needed to cover the floor of a rectangular room 14 feet by 18 feet?
33. A rectangular field is 68 feet long. If the perimeter of the field is 448 feet, determine the field's width and area.
34. A circular fishpond with a diameter of 12 feet is to have a 2 feet wide border of paver bricks as shown below. Find the area of the region where the paver bricks will go.

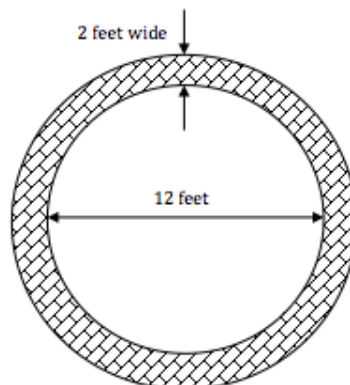

35. In the process of looking for a new dance studio, you come across two studios that you like the best. To help make an informed decision, you decide to determine which studio is a better deal for its size. 'Studio A' will cost \$1350 each month and 'Studio B' will cost \$1500 each month. For **each** of the floor plans below

- Find the square footage of the studio.
- Determine the cost per square foot.

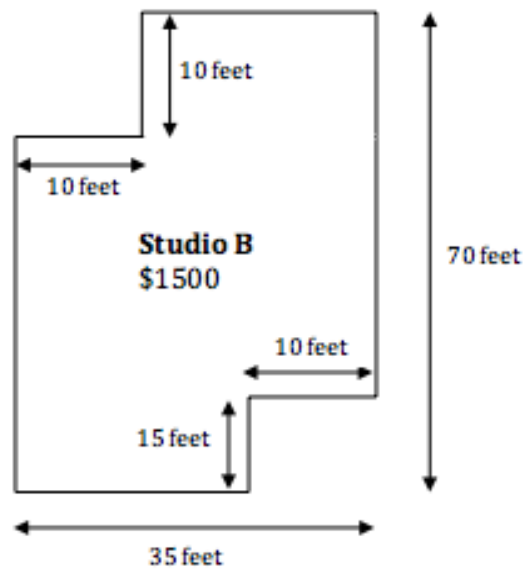
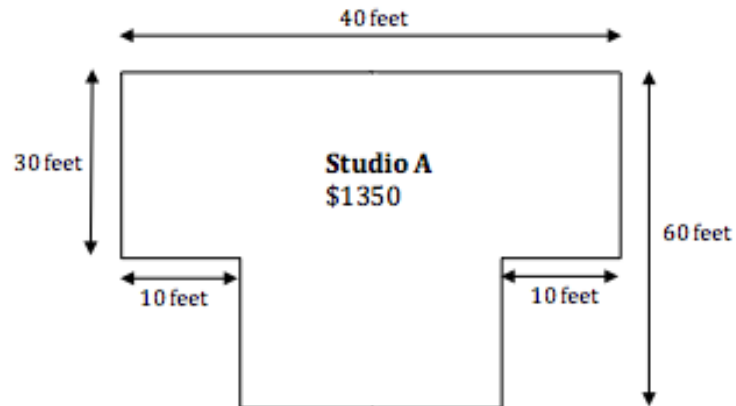

36. A farmer is fencing off part of his property where he would like his cattle to graze. The known lengths of the sides of the area to be fenced are shown in the diagram below. Round all answers to the nearest hundredth.
- Find the length of the fencing for the remaining side of the area being fenced off.
 - Find the area in square feet of the fenced off region.
 - Find the area in acres of the fenced off region.

Conversion factor: $1 \text{ acre} = 43,560 \text{ square feet}$

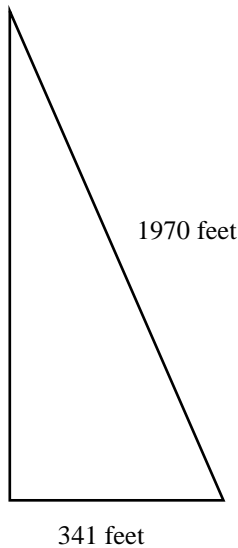

37. A rectangular swimming pool has a length of 13 feet, a width of 24 feet, and a depth of 5 feet. How many cubic feet of water can the pool hold?
38. A sports ball has a diameter of 30 cm. Find the volume of the ball (round to the nearest hundredth).
39. Callie is sending her nephew a soccer ball for his birthday. She packs the ball in a cubic box that has the same side length as the diameter of the ball. She needs to determine how much space needs to be filled with packing material. (Use 3.14 or the pi button on your calculator. Round all to the nearest hundredth.) If the sides of the box are 22 cm:
- What is the volume of the box?
 - What is the volume of the ball?
 - What is the remaining volume of the box that needs to be filled with packing material?

Chapter 2 – Measurement and Dimensional Analysis

Chapter 2 Learning Objectives:

- Use dimensional analysis to convert between different units of measurement for length, mass, and capacity
- Use dimensional analysis to convert between units of measurement in the metric system
- Use dimensional analysis to convert between the metric and standard systems of measurement
- Use rates and unit rates to problem solve

Section 2.1 – Length

Section 2.2 - Weight

Section 2.3 - Capacity

Section 2.4 - The Metric System

Section 2.5 - Converting Between Systems

Section 2.6 – Problem Solving Using Rates and Dimensional Analysis

Measurement is a number that describes the size or amount of something. You can measure many things like length, area, capacity, weight, temperature and time.

At times, you may need to convert between units of measurement. For example, you might want to express your height using feet and inches (5 feet 4 inches) or using only inches (64 inches). This process of converting from one unit to another unit is called **unit analysis** or **dimensional analysis**.

Section 2.1 – Length

Length is the distance from one end of an object to the other end, or from one object to another. For example, the length of a letter-sized piece of paper is 11 inches. The system for measuring length in the United States is based on the four customary units of length: **inch**, **foot**, **yard**, and **mile**. You can use any of these four U.S. customary measurement units to describe the length of something, but it makes more sense to use certain units for certain purposes. For example, it makes more sense to describe the length of a rug in feet rather than miles, and to describe a marathon in miles rather than inches.

The table below shows equivalents and conversion factors for the four customary units of measurement of length.

Unit Equivalents	Conversion Factors (longer to shorter units of measurement)	Conversion Factors (shorter to longer units of measurement)
1 foot = 12 inches	$\frac{12 \text{ inches}}{1 \text{ foot}}$	$\frac{1 \text{ foot}}{12 \text{ inches}}$

1 yard = 3 feet	$\frac{3 \text{ feet}}{1 \text{ yard}}$	$\frac{1 \text{ yard}}{3 \text{ feet}}$
1 mile = 5,280 feet	$\frac{5,280 \text{ feet}}{1 \text{ mile}}$	$\frac{1 \text{ mile}}{5,280 \text{ feet}}$

You can use the conversion factors to convert a measurement, such as feet, to another type of measurement, such as inches. Note that each of these conversion factors is a ratio of equal values, so each conversion factor equals 1. Multiplying a measurement by a conversion factor does not change the size of the measurement at all since it is the same as multiplying by 1; it just changes the units that you are using to measure.

There are many more inches for a measurement than there are feet for the same measurement, as feet is a longer unit of measurement. So, you could use the conversion factor $\frac{12 \text{ inches}}{1 \text{ foot}}$.

If a length is measured in feet, and you'd like to convert the length to yards, you can think, "I am converting from a shorter unit to a longer one, so the length in yards will be less than the length in feet." You could use the conversion factor $\frac{1 \text{ yard}}{3 \text{ feet}}$.

Dimensional Analysis: The Factor-Label Method

You can use the **factor label method** to convert a length from one unit of measure to another using the conversion factors. In the factor label method, you multiply by unit fractions to convert a measurement from one unit to another. Study the example below to see how the factor label method can be used to convert a measurement given in feet into an equivalent number of inches.

Example 1	
How many inches are in $3\frac{1}{2}$ feet?	
$3\frac{1}{2}$ feet = ____ inches	Begin by reasoning about your answer. Since a foot is longer than an inch, this means the answer would be greater than $3\frac{1}{2}$.
$3\frac{1}{2} \text{ feet} \cdot \frac{12 \text{ inches}}{1 \text{ foot}} = \underline{\hspace{2cm}}$ inches	Find the conversion factor that compares inches and feet, with "inches" in the numerator, and multiply.
$\frac{7 \text{ feet}}{2} \cdot \frac{12 \text{ inches}}{1 \text{ foot}} = \underline{\hspace{2cm}}$ inches	Rewrite the mixed number as an improper fraction before multiplying.

$$\frac{7 \cancel{\text{feet}}}{2} \cdot \frac{12 \text{ inches}}{1 \cancel{\text{foot}}} = \underline{\hspace{1cm}} \text{ inches}$$

You can cancel similar units when they appear in the numerator *and* the denominator. So here, cancel the similar units “feet” and “foot.” This eliminates this unit from the problem.

$$\frac{7}{2} \cdot \frac{12 \text{ inches}}{1} = \underline{\hspace{1cm}} \text{ inches}$$

$$\frac{7 \cdot 12 \text{ inches}}{2 \cdot 1} = \underline{\hspace{1cm}} \text{ inches}$$

Rewrite as multiplication of numerators and denominators.

$$\frac{84 \text{ inches}}{2} = 42 \text{ inches}$$

Divide.

There are 42 inches in $3\frac{1}{2}$ feet.

Notice that by using the factor label method you can cancel the units out of the problem, just as if they were numbers. You can only cancel if the unit being cancelled is in both the numerator and denominator of the fractions you are multiplying. In the problem above, you cancelled *feet* and *foot* leaving you with *inches*, which is what you were trying to find.

What if you had used the wrong conversion factor?

$$\frac{7 \text{ feet}}{2} \cdot \frac{1 \text{ foot}}{12 \text{ inches}} = ?$$

You could not cancel the feet because the unit is not the same in *both* the numerator and the denominator. So if you complete the computation, you would still have both feet and inches in the answer and no conversion would take place.

Example 2

An interior decorator needs border trim for a home she is wallpapering. She needs 15 feet of border trim for the living room, 30 feet of border trim for the bedroom, and 26 feet of border trim for the dining room. How many yards of border trim does she need?

$$15 \text{ feet} + 30 \text{ feet} + 26 \text{ feet} = 71 \text{ feet}$$

You need to find the total length of border trim that is needed for all three rooms in the house. Since the measurements for each room are given in feet, you can add the numbers.

$$71 \text{ feet} = \underline{\hspace{1cm}} \text{ yards}$$

How many yards is 71 feet?
Reason about the size of your answer. Since a yard is longer than a foot, there will be fewer yards. Expect your answer to be less than 71.

$$\frac{71 \text{ feet}}{1} \cdot \frac{1 \text{ yard}}{3 \text{ feet}} = \underline{\hspace{1cm}} \text{ yards} \quad \text{Use the conversion factor } \frac{1 \text{ yard}}{3 \text{ feet}}.$$

$$\frac{71 \cancel{\text{ feet}}}{1} \cdot \frac{1 \text{ yard}}{3 \cancel{\text{ feet}}} = \underline{\hspace{1cm}} \text{ yards} \quad \text{Since "feet" is in the numerator and denominator, you can cancel this unit.}$$

$$\frac{71}{1} \cdot \frac{1 \text{ yard}}{3} = \underline{\hspace{1cm}} \text{ yards}$$

$$\frac{71 \cdot 1 \text{ yard}}{1 \cdot 3} = \underline{\hspace{1cm}} \text{ yards} \quad \text{Multiply.}$$

$$\frac{71 \text{ yards}}{3} = 23 \frac{2}{3} \text{ yards} \quad \text{Divide, and write as a mixed number.}$$

The interior decorator needs $23 \frac{2}{3}$ yards of border trim.

You Try 2.1

- Use the Factor-Label Method to determine the number of feet in $2 \frac{1}{2}$ miles.
- A fence company is measuring a rectangular area in order to install a fence around its perimeter. If the length of the rectangular area is 130 yards and the width is 75 feet, what is the total length of the distance to be fenced?

Section 2.2 - Weight

You often use the word **weight** to describe how heavy or light an object or person is. Weight is measured in the U.S. customary system using three units: ounces, pounds, and tons. An **ounce** is the smallest unit for measuring weight, a **pound** is a larger unit, and a **ton** is the largest unit. You can use any of the customary measurement units to describe the weight of something, but it makes more sense to use certain units for certain purposes. For example, it makes more sense to describe the weight of a human being in pounds rather than tons. It makes more sense to describe the weight of a car in tons rather than ounces.

The following table shows the unit conversions and conversion factors that are used to make conversions between customary units of weight.

Unit Equivalents	Conversion Factors (heavier to lighter units of measurement)	Conversion Factors (lighter to heavier units of measurement)
1 pound = 16 ounces	$\frac{16 \text{ ounces}}{1 \text{ pound}}$	$\frac{1 \text{ pound}}{16 \text{ ounces}}$
1 ton = 2,000 pounds	$\frac{2,000 \text{ pounds}}{1 \text{ ton}}$	$\frac{1 \text{ ton}}{2,000 \text{ pounds}}$

Example 3

Use the Factor Label Method to determine the number of ounces in $2\frac{1}{4}$ pounds.

$2\frac{1}{4}$ pounds = ___ ounces

Begin by reasoning about your answer. Since a pound is heavier than an ounce, expect your answer to be a number greater than $2\frac{1}{4}$.

$2\frac{1}{4}$ pounds $\cdot \frac{16 \text{ ounces}}{1 \text{ pound}} =$ ___ ounces

Multiply by the conversion factor that relates ounces and pounds: $\frac{16 \text{ ounces}}{1 \text{ pound}}$.

$\frac{9 \text{ pounds}}{4} \cdot \frac{16 \text{ ounces}}{1 \text{ pound}} =$ ___ ounces

Write the mixed number as an improper fraction. The common unit "pound" can be cancelled because it appears in both the numerator and denominator.

$\frac{9}{4} \cdot \frac{16 \text{ ounces}}{1} =$ ___ ounces

Multiply and simplify.

$\frac{9 \cdot 16 \text{ ounces}}{4 \cdot 1} =$ ___ ounces

$\frac{144 \text{ ounces}}{4} = 36 \text{ ounces}$

There are 36 ounces in $2\frac{1}{4}$ pounds.

There are times when you need to perform calculations on measurements that are given in different units. To solve these problems, you need to convert one of the measurements to the same unit of measurement as the other measurement. Think about whether the unit you are converting to is smaller or larger than the unit you are converting from. This will help you be sure that you are making the right computation. You can use the factor label method to make the conversion from one unit to another.

The following examples require converting between units of weight.

Example 4

A municipal trash facility allows a person to throw away a maximum of 30 pounds of trash per week. Last week, 140 people threw away the maximum allowable trash. How many tons of trash did this equal?

$140 \cdot 30 \text{ pounds} = 4,200 \text{ pounds}$ Determine the total trash for the week expressed in pounds.
If 140 people each throw away 30 pounds, you can find the total by multiplying.

$4,200 \text{ pounds} = \underline{\hspace{1cm}} \text{ tons}$ Then convert 4,200 pounds to tons.
Reason about your answer. Since a ton is heavier than a pound, expect your answer to be a number less than 4,200.

$\frac{4,200 \cancel{\text{ pounds}}}{1} \cdot \frac{1 \text{ ton}}{2,000 \cancel{\text{ pounds}}} = \underline{\hspace{1cm}} \text{ tons}$ Find the conversion factor appropriate for the situation:
 $\frac{1 \text{ ton}}{2,000 \text{ pounds}}$

$\frac{4,200}{1} \cdot \frac{1 \text{ ton}}{2,000} = \underline{\hspace{1cm}} \text{ tons}$

$\frac{4,200 \cdot 1 \text{ ton}}{1 \cdot 2,000} = \underline{\hspace{1cm}} \text{ tons}$ Multiply and simplify.

$\frac{4,200 \text{ ton}}{2,000} = 2\frac{1}{10} \text{ tons}$ The total amount of trash generated is $2\frac{1}{10}$ tons.

Example 5

The post office charges \$0.44 to mail something that weighs an ounce or less. The charge for each additional ounce, or fraction of an ounce, of weight is \$0.17. At this rate, how much will it cost to mail a package that weighs 2 pounds 3 ounces?

$2 \text{ pounds } 3 \text{ ounces} = \underline{\hspace{1cm}} \text{ ounces}$ Since the pricing is for ounces, convert the weight of the package from pounds and ounces into just ounces.

$\frac{2 \text{ pounds}}{1} \cdot \frac{16 \text{ ounces}}{\text{pound}} = \underline{\hspace{1cm}} \text{ ounces}$ First use the factor label method to convert 2 pounds to ounces.

$$\frac{2 \cancel{\text{ pounds}}}{1} \cdot \frac{16 \text{ ounces}}{\cancel{\text{ pound}}} = \underline{\quad} \text{ ounces} \quad 2 \text{ pounds} = 32 \text{ ounces.}$$

$$\frac{2}{1} \cdot \frac{16 \text{ ounces}}{1} = 32 \text{ ounces} \quad \text{Add the additional 3 ounces to find the weight of the package. The package weighs 35 ounces. There are 34 additional ounces, since}$$

$$32 \text{ ounces} + 3 \text{ ounces} = 35 \text{ ounces} \quad 35 - 1 = 34.$$

$$\$0.44 + \$0.17(34) \quad \text{Apply the pricing formula. } \$0.44 \text{ for the first ounce and } \$0.17 \text{ for each additional ounce.}$$

$$\$0.44 + \$5.78$$

$$\$0.44 + \$5.78 = \$6.22$$

It will cost \$6.22 to mail a package that weighs 2 pounds 3 ounces.

You Try 2.2

- How many pounds is 72 ounces?
- The average weight of a northern Bluefin tuna is 1,800 pounds. The average weight of a great white shark is $2\frac{1}{2}$ tons. On average, how much more does a great white shark weigh, in pounds, than a northern bluefin tuna?

Section 2.3 - Capacity

Capacity is the amount of liquid (or other pourable substance) that an object can hold when it's full. When a liquid, such as milk, is being described in gallons or quarts, this is a measure of capacity.

There are five main units for measuring capacity in the U.S. customary measurement system. The smallest unit of measurement is a **fluid ounce**. "Ounce" is also used as a measure of weight, so it is important to use the word "fluid" with ounce when you are talking about capacity. Sometimes the prefix "fluid" is not used when it is clear from the context that the measurement is capacity, not weight.

The other units of capacity in the customary system are the **cup**, **pint**, **quart**, and **gallon**. The table below describes each unit of capacity and provides an example to illustrate the size of the unit of measurement.

You can use any of these five measurement units to describe the capacity of an object, but it makes more sense to use certain units for certain purposes. For example, it makes more sense

to describe the capacity of a swimming pool in gallons and the capacity of an expensive perfume in fluid ounces.

The table below shows some of the most common equivalents and conversion factors for the five customary units of measurement of capacity.

Unit Equivalents	Conversion Factors (heavier to lighter units of measurement)	Conversion Factors (lighter to heavier units of measurement)
1 cup = 8 fluid ounces	$\frac{1 \text{ cup}}{8 \text{ fluid ounces}}$	$\frac{8 \text{ fluid ounces}}{1 \text{ cup}}$
1 pint = 2 cups	$\frac{1 \text{ pint}}{2 \text{ cups}}$	$\frac{2 \text{ cups}}{1 \text{ pint}}$
1 quart = 2 pints	$\frac{1 \text{ quart}}{2 \text{ pints}}$	$\frac{2 \text{ pints}}{1 \text{ quart}}$
1 quart = 4 cups	$\frac{1 \text{ quart}}{4 \text{ cups}}$	$\frac{4 \text{ cups}}{1 \text{ quart}}$
1 gallon = 4 quarts	$\frac{1 \text{ gallon}}{4 \text{ quarts}}$	$\frac{4 \text{ quarts}}{1 \text{ gallon}}$
1 gallon = 16 cups	$\frac{1 \text{ gallon}}{16 \text{ cups}}$	$\frac{16 \text{ cups}}{1 \text{ gallon}}$

As with converting units of length and weight, you can use the factor label method to convert from one unit of capacity to another.

Example 6	
Use the Factor Label Method to determine the number of pints in $2\frac{3}{4}$ gallons.	
$2\frac{3}{4} \text{ gallons} = \underline{\hspace{2cm}} \text{ pints}$	<p>Begin by reasoning about your answer. Since a gallon is larger than a pint, expect the answer in pints to be a number greater than $2\frac{3}{4}$.</p>
$\frac{11 \text{ gallons}}{4} \cdot \frac{4 \text{ quarts}}{1 \text{ gallon}} \cdot \frac{2 \text{ pints}}{1 \text{ quart}} = \underline{\hspace{2cm}} \text{ pints}$	<p>The table above does not contain a conversion factor for gallons and pints, so you cannot convert it in one step.</p>
$\frac{11 \cancel{\text{ gallons}}}{4} \cdot \frac{4 \cancel{\text{ quarts}}}{1 \cancel{\text{ gallon}}} \cdot \frac{2 \text{ pints}}{1 \cancel{\text{ quart}}} = \underline{\hspace{2cm}} \text{ pints}$	<p>However, you can use quarts as an intermediate unit, as shown here.</p>

$$\frac{11}{4} \cdot \frac{4}{1} \cdot \frac{2 \text{ pints}}{1} = \underline{\hspace{2cm}} \text{ pints}$$

Set up the equation so that two sets of labels cancel—gallons and quarts.

$$\frac{11 \cdot 4 \cdot 2 \text{ pints}}{4 \cdot 1 \cdot 1} = \underline{\hspace{2cm}} \text{ pints}$$

$$\frac{88 \text{ pints}}{4} = 22 \text{ pints}$$

$2\frac{3}{4}$ gallons is equivalent to 22 pints

Example 7

Natasha is making lemonade to bring to the beach. She has two containers. One holds one gallon and the other holds 2 quarts. If she fills both containers, how many cups of lemonade will she have?

1 gallon + 2 quarts = ___ cups This problem requires you to find the sum of the capacity of each container and then convert that sum to cups.

4 quarts + 2 quarts = 6 quarts First, find the sum in quarts. 1 gallon is equal to 4 quarts.

$$\frac{6 \text{ quarts}}{1} \cdot \frac{2 \text{ pints}}{1 \text{ quart}} \cdot \frac{2 \text{ cups}}{1 \text{ pint}} = \underline{\hspace{2cm}} \text{ cups}$$

Since the problem asks for the capacity in cups, convert 6 quarts to cups.

$$\frac{6 \cancel{\text{ quarts}}}{1} \cdot \frac{2 \cancel{\text{ pints}}}{1 \cancel{\text{ quart}}} \cdot \frac{2 \cancel{\text{ cups}}}{1 \cancel{\text{ pint}}} = \underline{\hspace{2cm}} \text{ cups}$$

Cancel units that appear in both the numerator and denominator.

Multiply.

$$6 \cdot 2 \cdot 2 = 24 \text{ cups}$$

Natasha will have 24 cups of lemonade.

Another way to work the problem above would be to first change 1 gallon to 16 cups and change 2 quarts to 8 cups. Then add: $16 + 8 = 24$ cups.

You Try 2.3

Alan is making chili. He is using a recipe that makes 24 cups of chili. He has a 5-quart pot and a 2-gallon pot and is trying to determine whether the chili will all fit in one of these pots. Which of the pots will fit the chili?

- A) The chili will not fit into either of the pots.
- B) The chili can fit into either pot.
- C) The chili will fit into the 5-quart pot only.
- D) The chili will fit into the 2-gallon pot only.

Section 2.4 - The Metric System

In the United States, both the **U.S. customary measurement system** and the **metric system** are used, especially in medical, scientific, and technical fields. In most other countries, the metric system is the primary system of measurement. If you travel to other countries, you will see that road signs list distances in kilometers and milk is sold in liters. People in many countries use words like “kilometer,” “liter,” and “milligram” to measure the length, volume, and weight of different objects. These measurement units are part of the metric system.

Unlike the U.S. customary system of measurement, the metric system is based on 10s. For example, a liter is 10 times larger than a deciliter, and a centigram is 10 times larger than a milligram. This idea of “10” is not present in the U.S. customary system—there are 12 inches in a foot, and 3 feet in a yard...and 5,280 feet in a mile!

What if you have to find out how many milligrams are in a decigram? Or, what if you want to convert meters to kilometers? Understanding how the metric system works is a good start.

What is Metric?

The metric system uses units such as **meter**, **gram**, and **liter** to measure length, mass, and liquid volume (capacity), just as the U.S. customary system uses feet, ounces, and quarts to measure these.

In addition to the difference in the basic units, the metric system is based on 10s, and different measures for length include kilometer, meter, decimeter, centimeter, and millimeter. Notice that the word “meter” is part of all of these units.

The metric system also applies the idea that units within the system get larger or smaller by a power of 10. This means that a meter is 100 times larger than a centimeter, and a kilogram is 1,000 times heavier than a gram. You will explore this idea a bit later. For now, notice how this idea of “getting bigger or smaller by 10” is very different than the relationship between units in the U.S. customary system, where 3 feet equals 1 yard, and 16 ounces equals 1 pound.

Length, Mass, and Volume



The table below shows the basic units of the metric system. Note that the names of all metric units follow from these three basic units.

Length	Mass	Volume
<i>basic units</i>		
meter	gram	liter
<i>other units you may see</i>		
kilometer	kilogram	dekaliter
centimeter	centigram	centiliter
millimeter	milligram	milliliter

In the metric system, the basic unit of length is the meter. A meter is slightly larger than a yardstick, or just over three feet.

The basic metric unit of mass is the gram. A regular-sized paperclip has a mass of about 1 gram. Among scientists, one gram is defined as the mass of water that would fill a 1-centimeter cube. You may notice that the word “mass” is used here instead of “weight.” In the sciences and technical fields, a distinction is made between weight and mass. Weight is a measure of the pull of gravity on an object. For this reason, an object’s weight would be different if it was weighed on Earth or on the moon because of the difference in the gravitational forces. However, the object’s mass would remain the same in both places because mass measures the amount of substance in an object. As long as you are planning on only measuring objects on Earth, you can use mass/weight fairly interchangeably—but it is worth noting that there is a difference!

Finally, the basic metric unit of volume is the liter. A liter is slightly larger than a quart.

 <p>The handle of a shovel is about 1 meter.</p>	 <p>A paperclip weighs about 1 gram.</p>	 <p>A medium-sized container of milk is about 1 liter.</p>
--	--	--

Prefixes in the Metric System

The metric system is a base 10 system. This means that each successive unit is 10 times larger than the previous one.

The names of metric units are formed by adding a prefix to the basic unit of measurement. To tell how large or small a unit is, you look at the **prefix**. To tell whether the unit is measuring length, mass, or volume, you look at the base.

Prefixes in the Metric System						
<i>kilo-</i>	<i>hecto-</i>	<i>deka-</i>	meter gram liter	<i>deci-</i>	<i>centi-</i>	<i>milli-</i>
1,000 times larger than base unit	100 times larger than base unit	10 times larger than base unit	base units	10 times smaller than base unit	100 times smaller than base unit	1,000 times smaller than base unit

Using this table as a reference, you can see the following:

- A kilogram is 1,000 times larger than one gram (so 1 kilogram = 1,000 grams).
- A centimeter is 100 times smaller than one meter (so 1 meter = 100 centimeters).
- A dekaliter is 10 times larger than one liter (so 1 dekaliter = 10 liters).

Here is a similar table that just shows the metric units of measurement for mass, along with their size relative to 1 gram (the base unit). The common abbreviations for these metric units have been included as well.

Measuring Mass in the Metric System						
kilogram (kg)	hectogram (hg)	dekagram (dag)	gram (g)	decigram (dg)	centigram (cg)	milligram (mg)
1,000 grams	100 grams	10 grams	gram	0.1 gram	0.01 gram	0.001 gram

Since the prefixes remain constant through the metric system, you could create similar charts for length and volume. The prefixes have the same meanings whether they are attached to the units of length (meter), mass (gram), or volume (liter).

Converting Within the Metric System

While knowing the different units used in the metric system is important, the real purpose behind learning the metric system is for you to be able to use these measurement units to calculate the size, mass, or volume of different objects. In practice, it is often necessary to convert one metric measurement to another unit—this happens frequently in the medical, scientific, and technical fields, where the metric system is commonly used.

The table below shows some of the **unit equivalents** and **unit fractions** for length in the metric system.

Unit Equivalents	Conversion Factors	
1 meter = 1,000,000 micrometers	$\frac{1\ m}{1,000,000\ \mu m}$	$\frac{1,000,000\ \mu m}{1\ m}$
1 meter = 1,000 millimeters	$\frac{1\ m}{1,000\ mm}$	$\frac{1,000\ mm}{1\ m}$
1 meter = 100 centimeters	$\frac{1\ m}{100\ cm}$	$\frac{100\ cm}{1\ m}$
1 meter = 10 decimeters	$\frac{1\ m}{10\ dm}$	$\frac{10\ dm}{1\ m}$
1 dekameter = 10 meters	$\frac{1\ dam}{10\ m}$	$\frac{10\ m}{1\ dam}$

1 hectometer = 100 meters	$\frac{1 \text{ hm}}{100 \text{ m}}$	$\frac{100 \text{ m}}{1 \text{ hm}}$
1 kilometer = 1,000 meters	$\frac{1 \text{ km}}{1,000 \text{ m}}$	$\frac{1,000 \text{ m}}{1 \text{ km}}$
1 megameter = 1,000,000 meters	$\frac{1 \text{ Mm}}{1,000,000 \text{ m}}$	$\frac{1,000,000 \text{ m}}{1 \text{ Mm}}$

Notice that all of the unit fractions contain a factor of 10. Remember that the metric system is based on the notion that each unit is 10 times larger than the one that came before it.

Example 8	
Convert 7,225 centimeters to meters.	
$7,225 \text{ cm} = \underline{\hspace{1cm}} \text{ m}$	Meters is larger than centimeters, so you expect your answer to be less than 7,225.
$\frac{7,225 \text{ cm}}{1} \cdot \frac{1 \text{ m}}{100 \text{ cm}} = \underline{\hspace{1cm}} \text{ m}$	Using the factor label method, write 7,225 cm as a fraction and use unit fractions to convert it to m.
$\frac{7,225 \cancel{\text{cm}}}{1} \cdot \frac{1 \text{ m}}{100 \cancel{\text{cm}}} = \underline{\hspace{1cm}} \text{ m}$	Cancel similar units, multiply, and simplify.
$\frac{7,225}{1} \cdot \frac{1 \text{ m}}{100} = \frac{7,225}{100} \text{ m}$	
$\frac{7,225 \text{ m}}{100} = 72.25 \text{ m}$	$7,225 \text{ centimeters} = 72.25 \text{ meters}$

Learning how to solve real-world problems using metric conversions is as important as learning how to do the conversions themselves. Mathematicians, scientists, nurses, and even athletes are often confronted with situations where they are presented with information using metric measurements, and must then make informed decisions based on that data.

To solve these problems effectively, you need to understand the context of a problem, perform conversions, and then check the reasonableness of your answer. Do all three of these steps and you will succeed in whatever measurement system you find yourself using.

Example 9

In the Summer Olympic Games, athletes compete in races of the following lengths: 100 meters, 200 meters, 400 meters, 800 meters, 1500 meters, 5000 meters and 10,000 meters. If a runner were to run in all these races, how many kilometers would he run?

$$\begin{array}{r} 10,000 \\ 5,000 \\ 1,500 \\ 800 \\ 400 \\ 200 \\ + 100 \\ \hline 18,000 \end{array}$$

To figure out how many kilometers he would run, you need to first add all of the lengths of the races together and *then* convert that measurement to kilometers.

$$\frac{18,000 \text{ m}}{1} \cdot \frac{1 \text{ km}}{1,000 \text{ m}} = \underline{\hspace{2cm}} \text{ km}$$

Use the factor label method and unit fractions to convert from meters to kilometers.

$$\frac{18,000 \cancel{\text{ m}}}{1} \cdot \frac{1 \text{ km}}{1,000 \cancel{\text{ m}}} = \underline{\hspace{2cm}} \text{ km}$$

Cancel, multiply, and solve.

$$\frac{18,000}{1} \cdot \frac{1 \text{ km}}{1,000} = \frac{18,000 \text{ km}}{1,000}$$

$$\frac{18,000 \text{ km}}{1,000} = 18 \text{ km}$$

The runner would run 18 kilometers.

Example 10

One bottle holds 295 dL while another one holds 28,000 mL. What is the difference in capacity between the two bottles?

295 dL = ___ L The two measurements are in different units. You can
28,000 mL = ___ L convert both units to liters and then compare them.

$$\frac{295 \text{ dL}}{1} \cdot \frac{1 \text{ L}}{10 \text{ dL}} = \underline{\hspace{2cm}} \text{ L}$$

Convert dL to liters.

$$\frac{295 \cancel{\text{ dL}}}{1} \cdot \frac{1 \text{ L}}{10 \cancel{\text{ dL}}} = \underline{\hspace{2cm}} \text{ L}$$

Cancel similar units and multiply.

$$\frac{295}{1} \cdot \frac{1 \text{ L}}{10} = \underline{\hspace{2cm}} \text{ L}$$

$$\frac{295 \cdot 1L}{10} = 29.5L \quad 295 \text{ dL} = 29.5 \text{ liters.}$$

$$\frac{28,000 \text{ mL}}{1} \cdot \frac{1L}{1,000 \text{ mL}} = \underline{\hspace{2cm}}L \quad \text{Convert mL to liters.}$$

$$\frac{28,000}{1} \cdot \frac{1L}{1,000} = \frac{28,000}{1,000}L$$

$$\frac{28,000L}{1,000} = 28L \quad 28,000 \text{ mL} = 28 \text{ liters}$$

29.5 liters – 28 liters = 1.5 liters The question asks for “difference in capacity” between the bottles.

There is a difference in capacity of 1.5 liters between the two bottles.

Example 11

**A two-liter bottle contains 87 centiliters of oil and 4.1 deciliters of water.
How much more liquid is needed to fill the bottle?**

87 cL + 4.1 dL + ___ = 2 L You are looking for the amount of liquid needed to fill the bottle. Convert both measurements to liters and then solve the problem.

$$87 \text{ cL} = \underline{\hspace{1cm}}L \quad \text{Convert 87 cL to liters.}$$

$$\frac{87 \text{ cL}}{1} \cdot \frac{1L}{100 \text{ cL}} = \underline{\hspace{2cm}}L$$

$$\frac{87}{1} \cdot \frac{1L}{100} = \frac{87}{100}L$$

$$\frac{87L}{100} = 0.87L \quad 87 \text{ cL is equal to 0.87 liters}$$

$$4.1 \text{ dL} = \underline{\hspace{1cm}}L \quad \text{Convert 4.1 dL to liters.}$$

$$\frac{4.1 \text{ dL}}{1} \cdot \frac{1L}{10 \text{ dL}} = \underline{\hspace{2cm}}L$$

$$\frac{4.1}{1} \cdot \frac{1 L}{10} = \frac{4.1}{10} L$$

$$\frac{4.1 L}{10} = 0.41 L$$

4.1 dL is equal to 0.41 liters

2 liters – 0.87 liter – 0.41 liter = 0.72 liter Subtract to find how much more liquid is needed to fill the bottle.

The amount of liquid needed to fill the bottle is 0.72 liter.

You Try 2.4

- a. Complete the table below.

	Centimeters	Meters	Kilometers
Distance from Scottsdale to Las Vegas			421

- b. One boxer weighs in at 85 kg. He is 80 dekagrams heavier than his opponent. How much does his opponent weigh?

Section 2.5 – Converting Between Systems

We have spent the last several sections learning about the U.S. customary system of measurement, and the metric system. As you might guess, there are many applications where it is useful to be able to convert between measurements of length, mass, and volume (capacity) in the two systems.

The table below gives some useful conversions between U.S. and metric measurements:

	Approximate Conversions Between Customary and Metric Systems
Length	1 inch = 2.540 centimeters
	1 foot = 0.3048 m
	1 yard = 0.9144 meters
	1 mile = 1.6093 kilometers
Mass	1 pound = 0.4536 kilograms
	1 ounce = 28 grams
Volume	1 fluid ounce = 29.574 milliliters
	1 quart = 0.9464 liters
	1 gallon = 3.785 liters

Example 12

An Olympic sprinter competes in the 400m dash. How many yards is the race?

400 m = ___ y A yard is less than a meter, so you expect your answer to be more than 400.

$$\frac{400 \text{ m}}{1} \cdot \frac{1 \text{ yard}}{0.9144 \text{ m}}$$

Using the factor label method, write 400 m as a fraction and use unit fractions to convert it to yards.

$$\frac{400 \cancel{\text{ m}}}{1} \cdot \frac{1 \text{ yard}}{0.9144 \cancel{\text{ m}}} = \text{___ yards}$$

Cancel similar units, multiply, and simplify.

$$\frac{400}{1} \cdot \frac{1 \text{ yard}}{0.9144} = \frac{400}{0.9144} \text{ yards}$$

$$\frac{400}{0.9144} = 437.45 \text{ yards}$$

400 meters = 437.45 yards

The race is 437.45 yards.

Example 13

A patient must be weighed prior to surgery so that the proper dosage of anesthesia can be given. A nurse weighs a patient and finds that he weighs 205 pounds. The anesthesiologist prefers weights in kilograms. What is the patient's weight in kilograms? Round to the nearest hundredth.

205 lbs = ___ kg Pounds are smaller than kilograms, so you expect your answer to be less than 205.

$$\frac{205 \text{ lbs}}{1} \cdot \frac{1 \text{ kg}}{2.2 \text{ lbs}}$$

Using the factor label method, write 205 lbs as a fraction and use unit fractions to convert it to kilograms.

$$\frac{205 \cancel{\text{ lbs}}}{1} \cdot \frac{1 \text{ kg}}{2.2 \cancel{\text{ lbs}}} = \text{___ kg}$$

Cancel similar units, multiply, and simplify.

$$\frac{205}{1} \cdot \frac{1 \text{ kg}}{2.2} = \frac{205 \cdot 1}{1 \cdot 2.2} \text{ kg}$$

$$\frac{205}{2.2} = 93.18 \text{ kg}$$

205 lbs is equal to 93.18 kg

The patient's weight is 93.18 kg.

Example 14

Your work is having its annual potluck, and you are asked to bring 5 gallons of lemonade. When you go to the store, each container of lemonade mix says it will make 6 liters. How many containers do you need to buy?

5 gal = ___ L Liters are smaller than gallons, so you expect your answer to be more than 5.

$$\frac{5 \text{ gal}}{1} \cdot \frac{3.785 \text{ L}}{1 \text{ gal}}$$

Using the factor label method, write 5 gal as a fraction and use unit fractions to convert it to liters.

$$\frac{5 \text{ gal}}{1} \cdot \frac{3.785 \text{ L}}{1 \text{ gal}} = \text{___} \text{ liters}$$

Cancel similar units, multiply, and simplify.

$$\frac{5}{1} \cdot \frac{3.785 \text{ L}}{1} = \frac{5 \cdot 3.785}{1} \text{ liters}$$

$$5 \cdot 3.785 = 18.925 \text{ liters}$$

$$5 \text{ gallons} = 18.925 \text{ liters}$$

$$\frac{18.925 \text{ L}}{1} \cdot \frac{1 \text{ container}}{6 \text{ L}}$$

You need 18.925 liters, and each container of mix will make 6 liters.

$$\frac{18.925}{6} = 3.15 \text{ containers}$$

You must buy 4 containers of mix (3 is not enough)

Temperature Conversions

There are three commonly used systems for measuring temperature. One such system is usually used in science, and is called the **Kelvin** scale. We will focus our attention on the other two scales for measuring temperature: Fahrenheit and Celsius. The United States usually uses the **Fahrenheit** system. In this system, water freezes to ice at 32°F and boils at 212°F. Another commonly used temperature scale is the **Celsius** scale, where water freezes to ice at 0°C and boils at 100°C. You might notice that in the Fahrenheit scale there is a 180 degree difference (212°F – 32°F) between the temperature where water boils and freezes, while in the Celsius scale there is a 100 degree difference (100°C – 0°C) between the temperature where water boils and freezes. Since neither of these two temperature scales has an absolute starting point (a lowest possible temperature) we cannot meaningfully compare temperatures in these scales using conversion factors.

Instead, we have temperature conversion formulas which allow us to convert temperatures back and forth between Fahrenheit and Celsius.

To Convert Between	Conversion Formula
Celsius and Fahrenheit	$F = 1.8C + 32$

Example 15

Your front yard is full of weeds, so you decide to spray it with weed killer. The bottle of weed killer that you purchase says “Do not apply in temperatures below 18°C or above 32°C. What are the corresponding temperatures in degrees Fahrenheit?”

$$F = 1.8C + 32$$

Both temperatures are in degrees Celsius and need to be converted into degrees Fahrenheit.

$$F = 1.8(18) + 32$$

$$F = 64.4^{\circ}\text{F}$$

The lower temperature corresponds to 64.4°F.

$$F = 1.8(32) + 32$$

$$F = 89.6^{\circ}\text{F}$$

The upper temperature corresponds to 89.6°F.

The weed killer should only be applied when the temperature is between 64.4 and 89.6°F.

Example 16

When leaving the hospital with your sick child, you are told to return immediately if her temperature exceeds 101.5°F. When you get home, you discover your thermometer will only measure temperature in degrees Celsius. At what temperature, in degrees Celsius, would you need to return your child to the hospital?

$$F = 1.8C + 32$$

The temperature is in degrees Fahrenheit and it needs to be converted into degrees Celsius.

$$101.5 = 1.8(C) + 32$$

$$101.5 - 32 = 1.8C$$

Subtract 32 from both sides of the equation.

$$69.5 = 1.8C$$

Divide both sides by 1.8

$$C = \frac{69.5}{1.8}$$

$$C = 38.61^{\circ}\text{C}$$

You should return your child to the hospital if her temperature exceeds 38.61°C.

You Try 2.5

What was the temperature in degrees Celsius, if the evening news reports that the high temperature in Phoenix, Arizona today was 115°F?

Section 2.6 – Problem Solving Using Rates and Dimensional Analysis

A **rate** is the ratio of two quantities. A **unit rate** is a rate with a denominator of one.

Example 17

Your car can drive 300 miles on a tank of 15 gallons.
Express this as a rate and as a unit rate, in miles per gallon.

Expressed as a rate, $\frac{300 \text{ miles}}{15 \text{ gallons}}$.

We can divide to find a unit rate: $\frac{20 \text{ miles}}{1 \text{ gallon}}$, which we could also write as $20 \frac{\text{miles}}{\text{gallon}}$,
or just 20 miles per gallon.

Notice that, had we wanted to find the unit rate in **gallons per mile**, we would have had to invert the original rate:

$$\frac{15 \text{ gallons}}{300 \text{ miles}} = \frac{15}{300} \text{ gallons per mile} = \frac{1}{20} \text{ gallon per mile}$$

You Try 2.6

Find the unit rates. If necessary, round your answers to the nearest hundredth.
6 pounds for \$5.29

_____ dollars per pound

_____ pounds per dollar

Example 18

Compare the electricity consumption per capita in China to the rate in Japan.

To address this question, we will first need data. From the CIA¹ website we can find the electricity consumption in 2011 for China was 4,693,000,000,000 KWH (kilowatt-hours), or 4.693 trillion KWH, while the consumption for Japan was 859,700,000,000, or 859.7 billion KWH. To find the rate per capita (per person), we will also need the population of the two countries. From the World Bank², we can find the population of China is 1,344,130,000, or 1.344 billion, and the population of Japan is 127,817,277, or 127.8 million.

Computing the consumption per capita for each country:

$$\text{China: } \frac{4,693,000,000,000 \text{ KWH}}{1,344,130,000 \text{ people}} \approx 3491.5 \text{ KWH per person}$$

¹ <https://www.cia.gov/library/publications/the-world-factbook/rankorder/2042rank.html>

² <http://data.worldbank.org/indicator/SP.POP.TOTL>

$$\text{Japan: } \frac{859,700,000,000 \text{ KWH}}{127,817,277 \text{ people}} \approx 6726 \text{ KWH per person}$$

While China uses more than 5 times the electricity of Japan overall, because the population of Japan is so much smaller, it turns out Japan uses almost twice the electricity per person compared to China.

Many problems can also be solved by multiplying a quantity by rates to change the units. This is the foundation of the Factor-Label process that we have been using already in this chapter.

Example 19

Your car can drive 300 miles on a tank of 15 gallons.

- How far can it drive on 40 gallons?
- How many gallons are needed to drive 50 miles?

We earlier found that 300 miles on 15 gallons gives a rate of 20 miles per gallon.

a. If we multiply the given 40 gallon quantity by this rate, the *gallons* unit “cancels” and we’re left with a number of miles:

$$40 \text{ gallons} \cdot \frac{20 \text{ miles}}{\text{gallon}} = \frac{40 \text{ gallons}}{1} \cdot \frac{20 \text{ miles}}{\text{gallon}} = 800 \text{ miles}$$

Notice that this could also have been achieved using the rate given in the problem:

$$40 \text{ gallons} \cdot \frac{300 \text{ miles}}{15 \text{ gallons}} = \frac{40 \text{ gallons}}{1} \cdot \frac{300 \text{ miles}}{15 \text{ gallons}} = \frac{40}{1} \cdot \frac{300 \text{ miles}}{15} = \frac{1200}{15} \text{ miles} = 800 \text{ miles}$$

b. Notice if instead we were asked “how many gallons are needed to drive 50 miles?” we could answer this question by inverting the 20 mile per gallon rate so that the *miles* unit cancels and we’re left with gallons:

$$50 \text{ miles} \cdot \frac{1 \text{ gallon}}{20 \text{ miles}} = \frac{50 \text{ miles}}{1} \cdot \frac{1 \text{ gallon}}{20 \text{ miles}} = \frac{50 \text{ gallons}}{20} = 2.5 \text{ gallons}$$

Example 20

A bicycle is traveling at 15 miles per hour. How many feet will it cover in 20 seconds?

To answer this question, we need to convert 20 seconds into feet. If we know the speed of the bicycle in feet per second, this question would be simpler. Since we don’t, we will need to do additional unit conversions. We will need to know that 5280 ft = 1 mile. We might start by converting the 20 seconds into hours:

$$20 \text{ seconds} \cdot \frac{1 \text{ minute}}{60 \text{ seconds}} \cdot \frac{1 \text{ hour}}{60 \text{ minutes}} = \frac{1}{180} \text{ hour}$$

Now we can multiply by the 15 miles/hr

$$\frac{1}{180} \text{ hour} \cdot \frac{15 \text{ miles}}{1 \text{ hour}} = \frac{1}{12} \text{ mile}$$

Now we can convert to feet

$$\frac{1}{12} \text{ mile} \cdot \frac{5280 \text{ feet}}{1 \text{ mile}} = 440 \text{ feet}$$

We could have also done this entire calculation in one long set of products:

$$20 \text{ seconds} \cdot \frac{1 \text{ minute}}{60 \text{ seconds}} \cdot \frac{1 \text{ hour}}{60 \text{ minutes}} \cdot \frac{15 \text{ miles}}{1 \text{ hour}} \cdot \frac{5280 \text{ feet}}{1 \text{ mile}} = 440 \text{ feet}$$

Example 21

You are walking through a hardware store and notice two sales on tubing.

- 3 yards of Tubing A costs \$5.49.
- Tubing B sells for \$1.88 for 2 feet.

Either tubing is acceptable for your project. Which tubing is less expensive?

Find the unit price for each tubing. This will make it easier to compare.

Tubing A: 3 yards = \$5.49

Tubing A is sold by the yard.

$$\frac{\$5.49 \div 3}{3 \text{ yards} \div 3} = \frac{\$1.83}{1 \text{ yard}}$$

Find the cost per yard of Tubing A by dividing the cost of 3 yards of the tubing by 3.

Tubing B: 2 feet = \$1.88

Tubing B is sold by the foot. Find the cost per foot by dividing \$1.88 by 2 feet.

$$\frac{\$1.88 \div 2}{2 \text{ feet} \div 2} = \frac{\$0.94}{1 \text{ foot}}$$

To compare the prices, you need to have the same unit of measure. You can choose to use dollars per foot (like we have for Tubing B) or dollars per yard (like we have for Tubing A). Either will work. For this example, we will go with dollars per yard.

Tubing A: \$1.83 per yard

$$\text{Tubing B: } \frac{\$0.94}{1 \text{ foot}} \cdot \frac{3 \text{ feet}}{1 \text{ yard}} = \frac{\$ \quad}{\quad \text{ yard}}$$

Use the conversion factor $\frac{3 \text{ feet}}{1 \text{ yard}}$

$$\frac{\$0.94}{\cancel{1 \text{ foot}}} \cdot \frac{\cancel{3 \text{ feet}}}{1 \text{ yard}} = \frac{\$2.82}{1 \text{ yard}}$$

Cancel and multiply.

\$2.82 per yard

Compare prices for 1 yard of each tubing.

Tubing A: \$1.83 per yard Tubing B: \$2.82 per yard

Tubing A is less expensive than Tubing B.

Example 22

The cost of gasoline in Arizona is about \$2.05 per gallon. When you travel over the border into Mexico, gasoline costs 14.81 pesos per liter. Where is gasoline more expensive?

Note: This problem requires a currency conversion factor. Currency conversions are constantly changing, but at the time of print \$1 = 18.68 pesos.

To answer this question, we need to convert from gallons to liters AND from U.S. dollars to Mexican pesos.

$$\frac{\$2.05}{1 \text{ gallon}} \cdot \frac{1 \text{ gallon}}{3.8 \text{ liters}} \cdot \frac{18.68 \text{ pesos}}{\$1}$$

$$\frac{\$2.05}{1 \text{ gallon}} \cdot \frac{1 \text{ gallon}}{3.8 \text{ liters}} \cdot \frac{18.68 \text{ pesos}}{\$1}$$

$$\frac{2.05}{1} \cdot \frac{1}{3.8 \text{ liters}} \cdot \frac{18.68 \text{ pesos}}{1} = \frac{2.05 \cdot 18.68 \text{ pesos}}{3.8 \text{ liters}}$$

$$\frac{2.05 \cdot 18.68 \text{ pesos}}{3.8 \text{ liters}} = 10.08 \text{ pesos per liter}$$

The price in Arizona of \$2.05 per gallon is equivalent to 10.08 pesos per liter. Since the actual price in Mexico is 14.81 pesos per liter, gasoline is more expensive in Mexico.

Chapter 2 – Answers to You Try Problems

2.1 a. 13200 feet b. 930 feet or 310 yards

2.2 a. 4.5 pounds b. 3200 pounds

2.3 D) The chili will fit into the 2-gallon pot only.

2.4 a.

Centimeters	Meters	Kilometers
42,100,000	421,000	421

b. 84.2kg

2.5 46.1°C

2.6 \$0.88 per pound, 1.13 pounds per dollar

Chapter 2 - Practice Problems

1. Use the Factor-Label Method to determine the number of inches in 8 feet.
2. Use the Factor-Label Method to determine the number of feet in 5 yards.
3. Use the Factor-Label Method to determine the number of inches in 6 yards.
4. Use the Factor-Label Method to determine the number of yards in 108 inches.
5. Use the Factor-Label Method to determine the number of yards in 203.1 miles. Round your answer to the nearest hundredth.
6. Use the Factor-Label Method to determine the number of inches in 275.2 miles.
7. The length of one student desk is 22 inches. If you line up 5 desks, what is the total length of the desks in feet?
8. You want to arrange your dorm room so that the length of your bed and the length of your desk are next to each other along the wall. Your bed is 80 inches long and your desk is 3 feet and 5 inches long. What is the total length of your bed and desk in feet?
9. Use the Factor-Label Method to determine the number of ounces in 4 pounds.
10. Use the Factor-Label Method to determine the number of pounds in 38 ounces. Round your answer to the nearest hundredth.
11. Use the Factor-Label Method to determine the number of tons in 413 ounces. Round your answer to the nearest thousandth.
12. Amy bought 5 lbs. 5 oz. of turkey cold cuts and 3 lbs. 15 oz. of ham cold cuts. How much did she buy in total? (You should convert any ounces over 15 into pounds).
13. Leslie had twin girls – the first baby weighed 5 lbs. 14 oz. and the second baby weighed 6 lbs. 4 oz. How much did the twin baby girls weigh together? (You should convert any ounces over 15 into pounds).
14. Use the Factor-Label Method to determine the number of gallons in 48 cups.
15. Use the Factor-Label Method to determine the number of cups in $9\frac{1}{2}$ gallons.
16. Use the Factor-Label Method to determine the number of fluid ounces in 9 quarts.
17. Betty brought one gallon of iced tea to a potluck and Denis brought 3 quarts of iced tea to the potluck. How many cups of iced tea are at the potluck?

18. Natasha is heating up four 18-fluid ounce cans of soup on her stovetop. What is the smallest pot she can use if she has a 2-quart, 3-quart, and 5-quart saucepan?
19. Use the Factor-Label Method to determine the number of centimeters in 7 meters.
20. Use the Factor-Label Method to determine the number of liters in 3520 milliliters.
21. Use the Factor-Label Method to determine the number of milliliters in 4.83 liters.
22. Use the Factor-Label Method to determine the number of meters in 4 millimeters.
23. Use the Factor-Label Method to determine the number of meters in 415 centimeters.
24. Use the Factor-Label Method to determine the number of kilograms in 1840 grams.
25. Use the Factor-Label Method to determine the number of grams in 6 kilograms.
26. Use the Factor-Label Method to determine the number of centimeters in 36.4 millimeters.
27. Use the Factor-Label Method to determine the number of milligrams in 0.0352 kilograms.
28. Apollo Spas services 176 hot tubs. If each hot tub needs 125 mL of muriatic acid, how many liters of acid are needed for all of the hot tubs?
29. A bicyclist rides 5500 meters, takes a break, and then rides an additional 4000 meters. How many kilometers did he ride?
30. Sandra has a small dog and two birds. Her dog weighs 3.2 kg. One bird weighs 112 grams and the other bird weighs 125 grams. How many more kg does the dog weigh when compared to the two birds?
31. Use the Factor-Label Method to determine the number of inches in 6 centimeters.
32. Use the Factor-Label Method to determine the number of centimeters in 4.5 inches.
33. Use the Factor-Label Method to determine the number of yards in 350 meters.
34. Use the Factor-Label Method to determine the number of kilometers in 7.2 miles.
35. Use the Factor-Label Method to determine the number of kilograms in 165 pounds.
36. Use the Factor-Label Method to determine the number of pounds in 0.8 kilograms.
37. Use the Factor-Label Method to determine the number of liters in 16 gallons.
38. An Olympic sprinter competes in the 400 meter dash. How many feet is the race?

39. Convert a temperature of 54°F to degrees Celsius.
40. Convert a temperature of 75°F to degrees Celsius.
41. Convert a temperature of -12°C to degrees Fahrenheit.
42. Convert a temperature of 37°C to degrees Fahrenheit.
43. You arrive in Paris with \$800. How many Euros do you have to spend? ($\$1 = 0.9033$ euros as of November, 2016)
44. A bicyclist is traveling at 540 feet in 30 seconds. Express this as a rate and as a unit rate, in feet per second.
45. Your car can drive 380 miles on a tank of 22 gallons.
 - a. How far can it drive on 50 gallons? Round your answer to the nearest hundredth.
 - b. How many gallons are needed to drive 650 miles? Round your answer to the nearest hundredth.
46. A bicycle is traveling at 16 miles per hour. How many feet will it cover in 40 seconds? Round your answer to the nearest tenth of a foot.
47. A car is traveling 33 miles per hour. How many feet will the car travel in 6 seconds? Round your answer to the nearest tenth of a foot.
48. A car is traveling at 60 kilometers per hour. How many meters does it travel in 4 seconds?
49. A car is driving at 100 kilometers per hour. How many meters does it travel in 2 seconds?
50. A chain weighs 10 pounds per foot. How many ounces will 4 inches weigh?
51. One 16-ounce can of vegetable soup costs \$1.34. One quart of vegetable soup costs \$3.49. Which option is less expensive?
52. An 8-foot length of 4 inch wide crown molding costs \$14. How much will it cost to buy 40 feet of crown molding?
53. A wire costs \$2 per meter. How much will 3 kilometers of wire cost?
54. A recipe for blueberry muffins states that it yields 12 muffins, with 270 calories per muffin. You instead decide to make mini-muffins, and the recipe yields 20 mini-muffins. If you eat 6 mini-muffins, how many calories will you consume?

55. Four 3-megawatt wind turbines can supply enough electricity to power 3000 homes. How many turbines would be required to power 55,000 homes?
56. A highway had a landslide, where 3,000 cubic yards of material fell on the road, requiring 200 dump truck loads to clear. On another highway, a slide left 40,000 cubic yards on the road. How many dump truck loads would be needed to clear this slide?
57. You read online that a 15-foot by 20-foot brick patio would cost about \$2,275 to have professionally installed. Estimate the cost of having an 18-foot by 22-foot brick patio installed. Round your answer to the nearest dollar.
58. The store is selling lemons at 2 for \$1. Each lemon yields about 2 tablespoons of juice. How much will it cost to buy enough lemons to make a 9-inch lemon pie requiring half a cup of lemon juice? (1 cup = 16 tablespoons)
59. When Ibuprofen is given for fever to children 6 months of age up to 2 years, the usual dose is 5 milligrams (mg) per kilogram (kg) of body weight. How much medicine would be a usual dose for an 18 month old weighing 28 pounds? Round your answer to the nearest milligram. (1kg = 2.2 pounds)
60. It is estimated that a driver takes, on average, 1.5 seconds from seeing an obstacle to reacting by applying the brake or swerving. How far will a car, traveling at 60 miles per hour, travel in feet before the driver reacts to an obstacle?
61. Sound travels about 750 miles per hour. If you stand in a canyon and sound a horn, you will hear an echo. Suppose it takes about 3 seconds to hear the echo. How far away is the canyon wall, in feet?
62. It takes a hose 2 minutes to fill a rectangular aquarium 9 inches long, 10 inches wide, and 13 inches tall. How long will it take the same hose to fill an aquarium measuring 21 inches by 27 inches by 35 inches? Round your answer to the nearest minute.
63. You want to put a 2-inch thick layer of topsoil for a new 20-foot by 30-foot garden. The dirt store sells by the cubic yards. How many cubic yards will you need to order? Round your answer to the nearest tenth.
64. Gasoline in Paris costs 1.32 euros per liter. What is the price of gas in dollars per gallon? (\$1 = 0.9033 euros as of November, 2016)
65. A 0.75 liter bottle of wine costs 83 euros. What is the price of the wine in dollars per ounce? (\$1 = 0.9033 euros as of November, 2016)

Chapter 3: Linear Functions

Chapter 3 Learning Objectives:

- Use function notation to represent the relationship between inputs and outputs
- Read function inputs and outputs from a graph, table, equation, or word problem
- Recognize a linear function, and identify the slope and initial value
- Calculate a slope and interpret it as a rate of change
- Use technology to create a scatterplot and find a linear regression equation
- Interpret the meaning of the slope and initial value of a regression equation
- Use a regression equation to predict the output for a given input
- Use technology to calculate the correlation
- Interpret the correlation from a value of r , or by looking at a scatterplot

Section 3.1 – Functions

Section 3.2 - Linear Functions

Section 3.3 – Linear Regression

Section 3.4 – Correlation

Section 3.1 – Functions

The natural world is full of relationships between quantities that change. When we see these relationships, it is natural for us to ask “If I know one quantity, can I then determine the other?” This establishes the idea of an input quantity, or independent variable, and a corresponding output quantity, or dependent variable. From this we get the notion of a functional relationship in which the output can be determined from the input.

For some quantities, like height and age, there are certainly relationships between these quantities. Given a specific person and any age, it is easy enough to determine their height, but if we tried to reverse that relationship and determine age from a given height, that would be problematic, since most people maintain the same height for many years.

A function is a rule for a relationship between an input, or independent, quantity and an output, or dependent, quantity in which each input value uniquely determines one output value. We say “the output is a function of the input.”

Function Notation

To simplify writing out expressions and equations involving functions, a simplified notation is often used.

FUNCTION NOTATION is used to indicate a functional relationship between two quantities as follows:

$$\text{Function Name (INPUT) = OUTPUT}$$

So, the statement $f(x) = y$ would refer to the function f , and correspond to the ordered pair (x,y) , where x is the input variable, and y is the output variable.

Rather than write “height is a function of age”, we could use the descriptive variable h to represent height and we could use the descriptive variable a to represent age.

“Height is a function of age”
 If we name the function f we write “ h is f of a ”
 or more simply “ $h = f(a)$ ”

We could instead name the function h and write “ $h(a)$ ”
 which is read “ h of a ” and still means “height is a function of age”.

Remember we can use any variable to name the function; the notation $h(a)$ shows us that h depends on a . The value “ a ” must be put into the function “ h ” to get a result. Be careful - the parentheses indicate that age is input into the function (Note: do not confuse these parentheses with multiplication!).

Example 1

The number of days in a month is a function of the name of the month, so if we name the function f , we could write “days = $f(\text{month})$ ” or $d = f(m)$. If we simply name the function d , we could write $d(m)$

For example, $d(\text{March}) = 31$, since March has 31 days. The notation $d(m)$ reminds us that the number of days, d is dependent on the name of the month, m . Here the number of days is the output, and the name of the month is the input.

Example 2

A function $P(n)$ gives the number of police officers in a town n years after 2000. What does $P(5) = 300$ tell us?

When we read $P(5) = 300$, we see the value for the input quantity of the function is 5, meaning 5 years after 2000. This gives us the year $2000 + 5 = 2005$. The output value is 300, the number of police officers.

So this tells us that in the year 2005 there were 300 police officers in the town.

When we work with functions, there are two typical things we do: evaluate and solve. **Evaluating a function** is what we do when we **know an input**, and use the function to determine the corresponding output. Evaluating will always produce one result, since each input of a function corresponds to exactly one output.

Solving equations involving a function is what we do when we **know an output**, and use the function to determine the inputs that would produce that output. Solving a function could produce more than one solution, since different inputs can produce the same output.

Example 3

Using the table shown, a) Evaluate $g(3)$ b) Determine n when $g(n) = 6$.

n	1	2	3	4	5
$g(n)$	8	6	7	6	8

- a) Evaluating $g(3)$ (read: “ g of 3”) means that we need to determine the output value of the function g given the input value of $n=3$. Looking at the table, we see the output corresponding to $n=3$ is $g(n)=7$, allowing us to conclude $g(3) = 7$.
- b) Determine n when $g(n) = 6$. Here, we need to determine what input (n) value(s) produce an output value of 6. Looking at the table we see there are two solutions: $n = 2$ and $n = 4$. When we input 2 into the function g , our output is 6. When we input 4 into the function g , our output is also 6.

You Try 3.1A

The function $k(m)$ is given by the table below.

m	-2	0	1	4	8	15
$k(m)$	4	8	32	51	33	1

- a. Evaluate $k(4)$. b. Determine m when $k(m)=8$.

Graphs as Functions

Oftentimes a graph of a relationship can be used to define a function. By convention, graphs are typically created with the input quantity along the horizontal axis and the output quantity along the vertical axis. The most common graph has y on the vertical axis and x on the horizontal axis, and we say y is a function of x , or $y = f(x)$ when the function is named f .

Evaluating a function using a graph requires taking the given input and using the graph to look up the corresponding output. Solving a function equation using a graph requires taking the given output and looking on the graph to determine the corresponding input.

Example 4

Given the graph below, a) Evaluate $f(2)$ b) Determine x when $f(x) = 4$

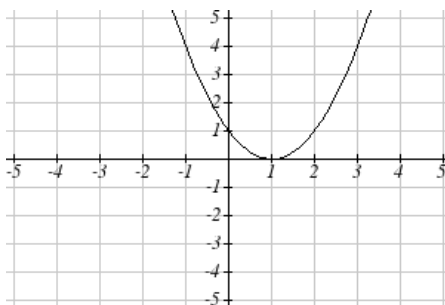

- a) To evaluate $f(2)$, we find the input of $x=2$ on the horizontal axis. Moving up to the graph gives the point $(2, 1)$, giving an output of $y=1$. So $f(2) = 1$
- b) To determine x when $f(x) = 4$, we find the value 4 on the vertical axis because if $f(x) = 4$ then 4 is the output. Moving horizontally across the graph gives two points with the output of 4: $(-1, 4)$ and $(3, 4)$. These give the two solutions to $f(x) = 4$: $x = -1$ or $x = 3$. This means $f(-1)=4$ and $f(3)=4$, or when the input is -1 or 3 , the output is 4.

You Try 3.1B

The function $f(x)$ is given below.

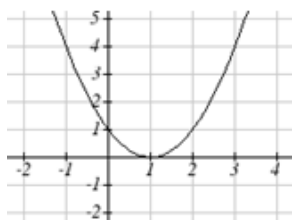

- a. Evaluate $f(1)$
- b. Determine x when $f(x)=1$.

Formulas as Functions

When possible, it is very convenient to define relationships using formulas. If it is possible to express the output as a formula involving the input quantity, then we can define a function. As with tables and graphs, it is common to evaluate and solve functions involving formulas. Evaluating will require replacing the input variable in the formula with the value provided and calculating. Solving will require replacing the output variable in the formula with the value provided, and solving for the input(s) that would produce that output.

Example 5

Given the function $k(t) = 2t + 5$

- Evaluate $k(8)$
- Determine t when $k(t) = 1$

a) To evaluate $k(8)$, we plug in the input value 8 into the formula wherever we see the input variable t , then simplify

$$k(8) = 2(8) + 5$$

$$k(8) = 16 + 5$$

$$\text{So } k(8) = 21$$

b) To determine t when $k(t) = 1$, we set the formula for $k(t)$ equal to 1, and solve for the input value that will produce that output

$$k(t) = 1 \quad \text{substitute the original formula } k(t) = 2t + 5$$

$$2t + 5 = 1 \quad \text{Solve for } t.$$

$$2t = -4$$

$$t = -2$$

When solving an equation using formulas, you can **check** your answer by using your solution in the original equation to see if your calculated answer is correct.

We want to know if $k(t) = 1$ is true when $t = -2$.

$$k(-2) = 2(-2) + 5$$

$$= -4 + 5$$

$$= 1 \quad \text{(which was the desired result).}$$

You Try 3.1C

Given the function $g(m) = 5m + 17$

- Evaluate $g(9)$
- Determine m when $g(m) = 2$

Graphical Behavior of Functions

As part of exploring how functions change, it is interesting to explore the graphical behavior of functions.

As we move from left to right (the inputs increase), we say a function is:

- **INCREASING** if the outputs get larger,
- **DECREASING** if the outputs get smaller,
- **CONSTANT** if the outputs do not change.

NOTE: We read graphs just like we read a book...from left to right.

The following functions are INCREASING

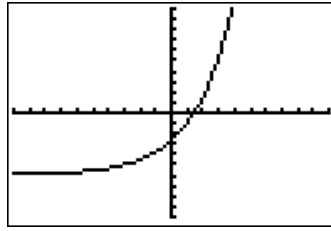
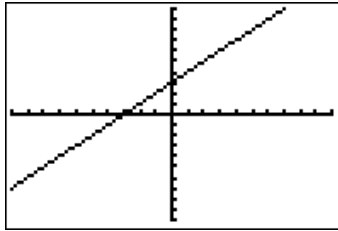

x	$f(x)$
0	4
1	6
2	12
3	24

The following functions are DECREASING

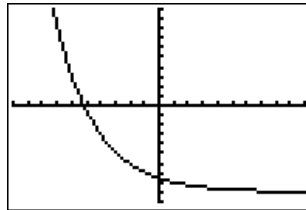
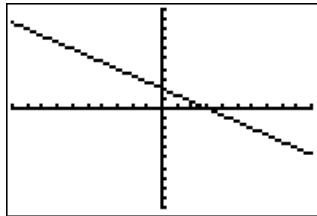

x	$g(x)$
0	10
1	5
2	0
3	-5

The following functions are CONSTANT

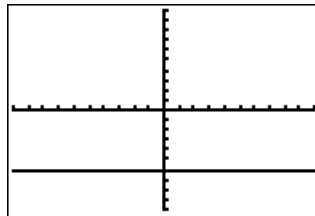
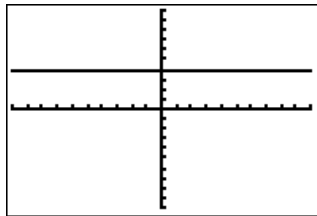

x	$h(x)$
0	4
1	4
2	4
3	4

Section 3.2 - Linear Functions

LINEAR FUNCTIONS

A linear function is a function whose graph produces a line.

Linear functions can always be written in the form:

$$f(x) = b + mx \quad \text{or} \quad f(x) = mx + b \quad \text{These are equivalent}$$

where b is the initial or starting value of the function (when input, $x = 0$), and m is the constant rate of change of the function.

Many people like to write linear functions in the form $f(x) = b + mx$ because it corresponds to the way we tend to speak: “The output starts at b and increases at a rate of m .”

For this reason alone we will use the form $f(x) = b + mx$ for many of the examples, but remember they are equivalent and can be written correctly both ways.

Here, m is the constant rate of change of the function (also called the **slope**). The slope determines if the function is an increasing function or a decreasing function.

If $m > 0$ then the function is **increasing**

If $m < 0$ then the function is **decreasing**

If $m = 0$, the rate of change is zero, and the function is a horizontal line

NOTE: A vertical line has a slope that is undefined. A vertical line is NOT a function.

Example 6

Marcus currently owns 200 songs in his iTunes collection. Every month, he adds 15 new songs. Write a formula for the number of songs, N , in his iTunes collection as a function of the number of months, m . How many songs will he own in a year?

The initial value for this function is 200, since he currently owns 200 songs, so $N(0) = 200$. The number of songs increases by 15 songs per month, so the rate of change is 15 songs per month. With this information, we can write the formula:

$$N(m) = 200 + 15m.$$

$N(m)$ is an increasing linear function.

With this formula we can predict how many songs he will have in 1 year (12 months): $N(12) = 200 + 15(12) = 200 + 180 = 380$. Marcus will have 380 songs in 12 months.

You Try 3.2A

You have just bought a new Sony 55" 3D television set for \$2300. The TV's value decreases at a rate of \$250 per year. Construct a linear function to represent this situation. Clearly indicate what your variables represent.

Calculating Rate of Change

Given two values for the input x_1 and x_2 , and two corresponding values for the output, y_1 and y_2 , or a set of points, (x_1, y_1) and (x_2, y_2) , if we wish to find a linear function that contains both points we can calculate the rate of change, m :

$$m = \frac{\text{change in output}}{\text{change in input}} = \frac{\Delta y}{\Delta x} = \frac{y_2 - y_1}{x_2 - x_1}$$

Rate of change of a linear function is also called the slope of the line.

Example 7

The population of a city increased from 23,400 to 27,800 between 2002 and 2006. Find the rate of change of the population during this time span.

The rate of change will relate the change in population to the change in time. The population increased by $27800 - 23400 = 4400$ people over the 4 year time interval. To find the rate of change, the number of people per year the population changed by:

$$\frac{4400 \text{ people}}{4 \text{ years}} = \frac{1100 \text{ people}}{1 \text{ year}} = 1100 \text{ people per year}$$

(Note: You should recognize the slope as a unit rate from chapter 2!)

Notice that we knew the population was increasing, so we would expect our value for m to be positive. This is a quick way to check to see if your value is reasonable.

You Try 3.2B

In the year 1998, the surface elevation of Lake Powell was 3,843 feet above sea level. In the year 2001, the surface elevation of Lake Powell was 3,609 feet above sea level. Determine the rate of change in this situation.

We can now find the rate of change given two input-output pairs, and can write an equation for a linear function once we have the rate of change and initial value. If we have two input-output pairs and they do not include the initial value of the function, then we will have to solve for it.

Example 8

Working as an insurance salesperson, David earns a base salary and a commission on each new policy, so David's weekly income, I , depends on the number of new policies, n , he sells during the week. Last week he sold 3 new policies, and earned \$760 for the week. The week before, he sold 5 new policies, and earned \$920. Find an equation for $I(n)$, and interpret the meaning of the components of the equation.

The given information gives us two input-output pairs: $(3,760)$ and $(5,920)$. We start by finding the rate of change.

$$m = \frac{920 - 760}{5 - 3} = \frac{160}{2} = \frac{80}{1} \text{ (or just 80)}$$

Keeping track of units can help us interpret this quantity. Income increased by \$160 when the number of policies increased by 2, so the rate of change is $\frac{\$80}{1 \text{ policy}}$. David earns a commission of \$80 for each policy sold during the week.

We can then solve for the initial value

$$\begin{aligned} I(n) &= b + 80n && \text{then when } n = 3, I(3) = 760, \text{ giving} \\ 760 &= b + 80(3) && \text{this allows us to solve for } b \\ b &= 760 - 80(3) = 520 \end{aligned}$$

This value is the starting value for the function. This is David's income when $n = 0$, which means no new policies are sold. We can interpret this as David's base salary for the week, which does not depend upon the number of policies sold.

Writing the final equation: $I(n) = 520 + 80n$

Our final interpretation is: David's base salary is \$520 per week and he earns an additional \$80 commission for each policy sold during the week.

You Try 3.2C

The balance in your college payment account, C , is a function of the number of quarters, q , you attend. Interpret the function $C(q) = 20000 - 4000q$ in words.

When working with applied problems involving functions, use the following strategy.

Problem Solving Strategy

- 1) Identify changing quantities, and then carefully and clearly define descriptive variables to represent those quantities. When appropriate, sketch a picture or define a coordinate system.
- 2) Carefully read the problem to identify important information. Look for information giving values for the variables, or values for parts of the functional model, like slope and initial value. Also identify what you are trying to find, identify, solve, or interpret.
- 3) Identify a solution pathway from the provided information to what we are trying to find. Often this will involve checking and tracking units, building a table or even finding a formula for the function being used to model the problem.
- 4) Solve or evaluate using the formula you found for the desired quantities.
- 5) Reflect on whether your answer is reasonable for the given situation and whether it makes sense mathematically.
- 6) Clearly convey your result using appropriate units, and answer in full sentences when appropriate.

This strategy will help you work through the following examples.

Example 9

Arielle saved up \$3500 for her summer visit to Seattle. She anticipates spending \$400 each week on rent, food, and fun. How long can she afford to stay in Seattle?

In the problem, there are two changing quantities: time and money. The amount of money she has remaining while on vacation depends on how long she stays. We can define our variables, including units.

Output: M , money remaining, in dollars

Input: t , time, in weeks

Reading the problem, we identify two important values. The first, \$3500, is the initial value for M . The other value appears to be a rate of change – the units of dollars per week match the units of our output variable divided by our input variable. She is spending money each week, so you should recognize that the amount of money remaining is decreasing each week and the slope is negative.

To answer the question, it would be helpful to have an equation modeling this scenario. Using the intercept and slope provided in the problem, we can write the equation: $M(t) = 3500 - 400t$, where M is the amount of money remaining after t weeks.

To find out how long she can stay, we need to find out how long it will take for her to use up all of the money she has saved. So we are looking for the number of weeks, t , when $M=0$. Set the output to zero, and solve for the input:

$$0 = 3500 - 400t$$

$$t = \frac{3500}{400} = 8.75$$

Interpreting this, we could say: **Arielle will have no money left after 8.75 weeks.**

When modeling any real life scenario with functions, there is typically a limited domain over which that model will be valid – almost no trend continues indefinitely. In this case, it certainly doesn't make sense to talk about input values less than zero. It is also likely that this model is not valid after the horizontal intercept (unless Arielle is going to start using a credit card and go into debt).

The domain represents the set of input values and so **the reasonable domain for this function is $0 \leq t \leq 8.75$.**

However, in a real world scenario, the rental might be weekly or nightly. She may not be able to stay a partial week and so all options should be considered. Arielle could stay in Seattle for 0 to 8 full weeks (and a couple of days), but would have to go into debt to stay 9 full weeks, so restricted to whole weeks, a reasonable domain without going in to debt would be $0 \leq t \leq 8$, or $0 \leq t \leq 9$ if she went into debt to finish out the last week.

The range represents the set of output values and she starts with \$3500 and ends with \$0 after 8.75 weeks so **the corresponding range is** $0 \leq M(t) \leq 3500$.

If we limit the rental to whole weeks however, if she left after 8 weeks because she didn't have enough to stay for a full 9 weeks, she would have $M(8) = 3500 - 400(8) = \$300$ dollars left after 8 weeks, giving a range of $300 \leq M(t) \leq 3500$. If she wanted to stay the full 9 weeks she would be \$100 in debt giving a range of $-100 \leq M(t) \leq 3500$.

Most importantly remember that domain and range are tied together, and whatever you decide is most appropriate for the domain (the independent variable) will dictate the requirements for the range (the dependent variable).

Example 10

Jamaal is choosing between two moving companies. The first, U-Haul, charges an up-front fee of \$20, then 59 cents per mile. The second, Budget, charges an up-front fee of \$16, then 63 cents per mile³. When will U-Haul be the better choice for Jamal?

The two important quantities in this problem are the cost, and the number of miles that are driven. Since we have two companies to consider, we will define two functions:

Input: m , miles driven

Outputs: $Y(m)$: cost, in dollars, for renting from U-Haul

$B(m)$: cost, in dollars, for renting from Budget

Reading the problem carefully, it appears that we were given an initial cost and a rate of change for each company. Since our outputs are measured in dollars but the costs per mile given in the problem are in cents, we will need to convert these quantities to match our desired units: \$0.59 a mile for U-Haul, and \$0.63 a mile for Budget.

Looking to what we're trying to find, we want to know when U-Haul will be the better choice. Since all we have to make that decision from is the costs, we are looking for when U-Haul will cost less, or when $Y(m) < B(m)$.

Using the rates of change and initial charges, we can write the equations:

$$Y(m) = 20 + 0.59m \qquad B(m) = 16 + 0.63m$$

These graphs are sketched below, with $Y(m)$ drawn dashed.

³ Rates retrieved Aug 2, 2010 from <http://www.budgettruck.com> and <http://www.uhaul.com/>

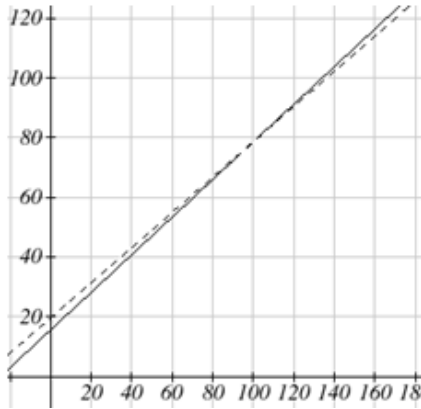

To find the intersection, we set the equations equal and solve: $Y(m) = B(m)$.

$$20 + 0.59m = 16 + 0.63m$$

$$-0.04m = -4$$

$$m = 100$$

This tells us that the cost from the two companies will be the same if 100 miles are driven. Either by looking at the graph, or noting that $Y(m)$ is growing at a slower rate, we can conclude that U-Haul will be the cheaper price when more than 100 miles are driven.

Example 11

A town's population has been growing linearly. In 2004 the population was 6,200. By 2009 the population had grown to 8,100. If this trend continues,

- Predict the population in 2013
- When will the population reach 15000?

The two changing quantities are the population and time.

Input: t , years since 2004 Output: $P(t)$, the town's population

The problem gives us two input-output pairs. Converting them to match our defined variables, the year 2004 would correspond to $t = 0$, giving the point $(0, 6200)$. Notice that through our clever choice of variable definition, we have "given" ourselves the vertical intercept of the function. The year 2009 would correspond to $t = 5$, giving the point $(5, 8100)$.

To predict the population in 2013 ($t = 9$), we would need an equation for the population. Likewise, to find when the population would reach 15000, we would need to solve for the input that would provide an output of 15000. Either way, we need an equation. To find it, we start by calculating the rate of change:

$$m = \frac{8100 - 6200}{5 - 0} = \frac{1900}{5} = \frac{380 \text{ people}}{1 \text{ year}} = 380 \text{ people per year}$$

Since we already know the vertical intercept of the line, we can immediately write the equation: $P(t) = 6200 + 380t$

To predict the population in 2013, we evaluate our function at $t = 9$

$$P(9) = 6200 + 380(9) = 9620$$

If the trend continues, our model predicts a population of 9,620 in 2013.

To find when the population will reach 15,000, we can set $P(t) = 15000$ and solve for t .

$$15000 = 6200 + 380t$$

$$8800 = 380t$$

$$t \approx 23.158$$

Our model predicts the population will reach 15,000 in a little more than 23 years after 2004, or somewhere around the year 2027.

You Try 3.2D

In 2004, a school population was 1001. By 2008 the population had grown to 1697. Assume the population is changing linearly.

- How much did the population grow between the year 2004 and 2008?
- How long did it take the population to grow from 1001 students to 1697 students?
- What is the average population growth per year?
- Find an equation for the population, P , of the school t years after 2004.
- Using your equation, predict the population of the school in 2011.

Section 3.3 – Linear Regression

In the last section we explored linear functions. Recall that linear functions have a constant rate of change, and can be written in the form $f(x) = b + mx$, or $f(x) = mx + b$. When graphed, a linear function is a straight line, where all points that satisfy the linear equation fall exactly on the graph of the line. This can be seen in the graph below:

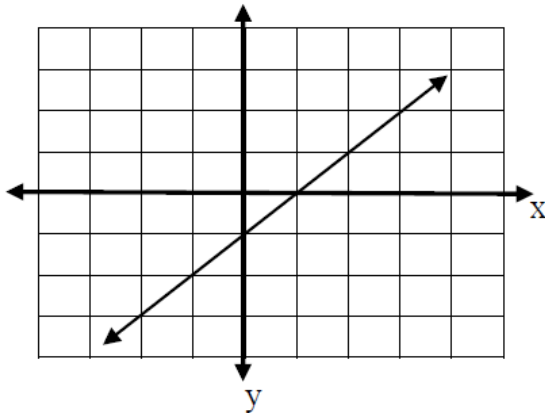

This is the graph of $f(x) = -1 + x$.

Some of the points on this line are: $(-2, -3)$, $(0, -1)$, $(1, 0)$, and $(3, 2)$. There are infinitely many other points on this line too.

Now consider the following graph that represents the relationship between the age of a vehicle (in years) and its value (in \$1000s) for 10 different vehicles.

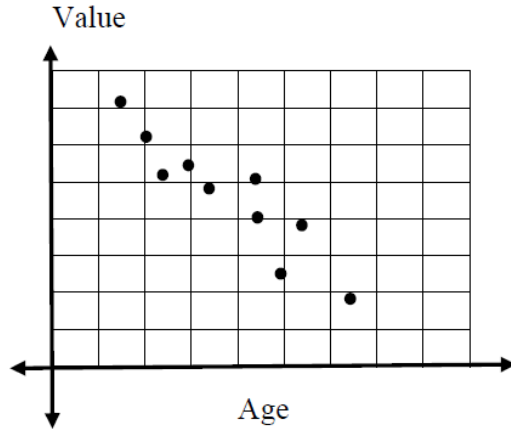

Can we write the equation of a linear function that represents this set of points?
No, not exactly.

There is no straight line that will go through ALL of these points, but there does appear to be a linear relationship between the two variables.

The graph that you see above is called a **scatterplot**. A scatterplot is used to show the relationship between two numerical variables. The **independent (predictor) variable** is plotted on the horizontal axis, and the **dependent (response) variable** is plotted on the vertical axis.

Example 12

The data below show a person's body weight during a diet program.

Time, t , in weeks	0	1	2	3	4	5
Weight, W , in pounds	196	192	193	190	190	186

Draw a scatterplot of the data. Does the data appear linear?

Step 1: Enter the data into your calculator

```

300) CALC TESTS
1) Edit...
2) SortA(
3) SortD(
4) ClrList
5) SetUpEditor
  
```

- Press STAT (Second Row of Keys)
- Press ENTER to access 1:Edit under EDIT menu
- *Note: Be sure all data columns are cleared. To do so, use your arrows to scroll up to L1 or L2 then click CLEAR then scroll down. (DO NOT CLICK DELETE!)*

Once your data columns are clear, enter the input data into L1 (press ENTER after each data value to get to the next row) then right arrow to L2 and enter the output data into L2. Your result should look like this when you are finished (for L1 and L2):

L1	L2	L3	1
-----	-----	-----	
L1(1) =			

L1	L2	L3	2
0	196	-----	
1	192		
2	193		
3	190		
4	190		
5	186		
-----	-----	-----	
L2(6) = 186			

Step 2: Turn on your Stat Plot

Plot1	Plot2	Plot3
✓ Y1 =		
✓ Y2 =		
✓ Y3 =		
✓ Y4 =		
✓ Y5 =		
✓ Y6 =		
✓ Y7 =		

- Press Y=
- Use your arrow keys to scroll up to Plot1
- Press ENTER
- Scroll down and Plot1 should be highlighted as at left
- Clear out all entries below

Step 3: Graph the Data in an Appropriate Viewing Window

Click the ZOOM key, and scroll down to Option 9: “ZoomStat”

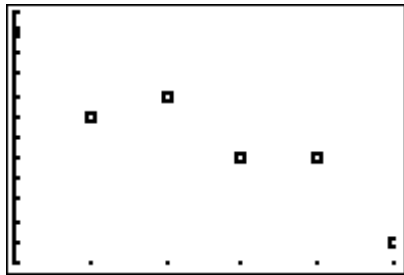

- Once your cursor is on “ZoomStat”, press the GRAPH key. A graph of your data should appear in an appropriate window so that all data points are clearly visible.

The scatterplot above shows that the data points seem to have a linear relationship.

From the previous scatterplot, it looks like there is a negative linear relationship between the time in weeks and the weight in pounds. We can see this linear relationship because the points are scattered around an imaginary straight line. More specifically, as the time increases, the weight seems to decrease by a fairly consistent amount.

You Try 3.3A

Consider the data set:

x	3	5	8	9	11	12	15
y	1.1	3.2	7.0	6.8	9.5	9.8	13.0

- a. Draw a scatterplot for the data set.
- b. Does the data set appear to be increasing or decreasing?
- c. Does the data set appear to have a linear relationship?

Just because data are not EXACTLY linear does not mean we cannot write an approximate linear model for the given data set. In fact, most data in the real world are NOT exactly linear and all we can do is write models that are close to the given values.

Once we have determined using a scatterplot that our two variables appear to have a roughly linear relationship, we can use a process called **linear regression** to find the equation of the line that best fits the data points. If you take a statistics class, you will learn a lot more about this process. In this class, you will be introduced to the basics. This process is also called “FINDING THE LINE OF BEST FIT”. This process is lengthy and calculation intensive by hand, but can be done quickly using our graphing calculator.

Our calculator will give us the best linear equation possible by taking into account ALL the given data points.

NOTE: Unless your data are exactly linear, the regression equation will not match all data points exactly. It is a model used to predict outcomes not provided in the data set.

Example 13

Consider the data set from the previous problem:

Time, t , in weeks	0	1	2	3	4	5
Weight, W , in pounds	196	192	193	190	190	186

Use your graphing calculator to find the regression equation.

Step 1: Enter the Data into your Graphing Calculator

Press STAT then select option 1:Edit under EDIT menu. Clear lists, then enter the values.

```

2nd 2nd CALC TESTS
1: Edit...
2: SortA(
3: SortD(
4: ClrList
5: SetUpEditor

```

L1	L2	L3	2
0	196	-----	
1	192		
2	193		
3	190		
4	190		
5	186		

L2(6) = 186			

****NOTE** If you ever accidentally **DELETE** a column, then go to **STAT, Option 5: SetUpEditor>ENTER**. When you go back to **STAT**, your column should be restored.

Step 2: Turn on your Stat Plot and Graph the Data in an Appropriate Viewing Window

(Refer to previous example for help)

```

2nd 2nd Plot1 Plot2 Plot3
Y1=
Y2=
Y3=
Y4=
Y5=
Y6=
Y7=

```

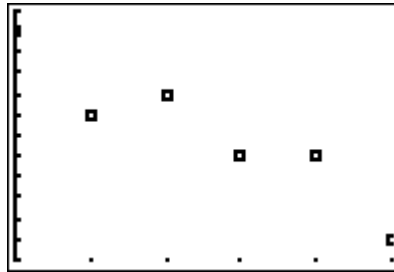

Note: Since we already graphed the scatterplot for this data set (and know the data looks linear), you could skip this step. Graphing the scatterplot is not required in order to calculate the regression equation, but you should always verify using a scatterplot that your data looks linear **BEFORE** doing a linear regression!

Step 3: Access the Linear Regression section of your calculator

```

EDIT 2nd 2nd TESTS
1: 1-Var Stats
2: 2-Var Stats
3: Med-Med
4: LinReg(ax+b)
5: QuadReg
6: CubicReg
7: QuartReg

```

- Press **STAT**
- Scroll to the right one place to **CALC**
- Scroll down to **4:LinReg(ax+b)**
- Your screen should look as the one at left

Step 4: Determine the linear regression equation

```

LinReg
y=ax+b
a=-1.685714286
b=195.3809524

```

- Press ENTER twice in a row to view the screen at left
- The calculator computes values for slope (a) and y-intercept (b) in what is called the equation of best-fit for your data.
- Identify these values and round to the appropriate places. Let's say 2 decimals in this case.
So, $a = -1.69$ and $b = 195.38$
- Now, replace the a and b in $y = ax + b$ with the rounded values to write the actual equation:
 $y = -1.69x + 195.38$
- To write the equation in terms of initial variables, we would write $W = -1.69t + 195.38$
- In function notation, $W(t) = -1.69t + 195.38$

Once we have the equation figured out, it's nice to graph it on top of our data to see how things match up.

GRAPHING THE REGRESSION EQUATION ON TOP OF THE STAT PLOT

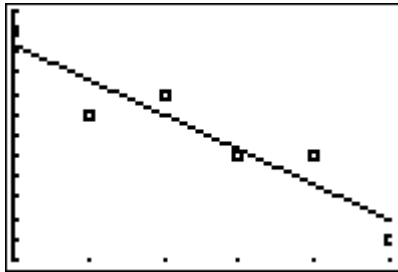

- Enter the Regression Equation with rounded values into Y=
- Press GRAPH
- You can see from the graph that the “best fit” line does not hit very many of the given data points. But, it will be the most accurate linear model for the overall data set.

IMPORTANT NOTE: When you are finished graphing your data, TURN OFF YOUR PLOT1. Otherwise, you will encounter an INVALID DIMENSION error when trying to graph other functions. To do this:

- Press Y=
- Use your arrow keys to scroll up to Plot1
- Press ENTER
- Scroll down and Plot1 should be UNhighlighted

You Try 3.3B

Consider the data set:

n	0	2	4	6	8	10	12
$f(n)$	23.76	24.78	25.93	26.24	26.93	27.04	27.93

Use your graphing calculator to find the linear regression equation for this data set.

Once you have a linear regression equation, you can then use that equation to provide you with information about *how your two variables change together*, and to make *predictions* about other values of your variables of interest.

Example 14

Consider again the data set from the previous problem:

Time, t , in weeks	0	1	2	3	4	5
Weight, W , in pounds	196	192	193	190	190	186

- a) Interpret the meaning of the vertical intercept.
- b) Interpret the meaning of the slope.
- c) Use your regression equation to predict the weight in pounds after 2.5 weeks.
- d) Use your regression equation to predict the weight in pounds after 6 weeks.

Recall, the regression equation for this data set was

```
LinReg
y=ax+b
a=-1.685714286
b=195.3809524
```

$$y = -1.69x + 195.38$$

To write the equation in terms of initial variables, we would write $W = -1.69t + 195.38$

- a) The vertical intercept is the value of W when $t = 0$. Based on the regression equation, we know that when $t = 0$, $W = 195.38$. This tells us that when first starting the weight loss program, the individual weighed approximately 195.38 pounds.

Note: In this particular case, we had a data point for time 0 weeks of 196 pounds. In general, the regression equation gives an estimate (or predicted value) of the response variable. Output from the regression equation will rarely equal the exact data values themselves.

- b) The slope of the regression equation is -1.69. Recall that the slope measures $\frac{\text{change in } y}{\text{change in } x}$, or in our problem, $\frac{\text{change in weight } (W)}{\text{change in time } (t)}$. We can write the slope for this equation of -1.69 as a fraction by writing it over 1:

$$\frac{\text{change in weight } (W)}{\text{change in time } (t)} = \frac{-1.69}{1}$$

To interpret the meaning of the slope, we would say that for each additional week, the weight decreases by approximately 1.69 pounds.

- c) To predict the weight in pounds after 2.5 weeks, plug in $t = 2.5$ to the regression equation, and solve for W .

$$W = -1.69(2.5) + 195.38$$

$$W = 191 \text{ pounds}$$

- d) To predict the weight in pounds after 6 weeks, plug in $t = 6$ to the regression equation, and solve for W .

$$W = -1.69(6) + 195.38$$

$$W = 185 \text{ pounds}$$

In the previous problem, we used our regression equation to tell us how our two variables change together, and to make predictions about other values. You may have noticed that we made predictions about the values of our dependent variable only for values of our independent variable that were close to the actual values in our data set. In other words, our original data set included values of time from 0-5 weeks. Based on that information, we created our model. It would not be appropriate to try to make predictions for values of time that are far outside our original range of time values (from 0 – 5 weeks). This is called **extrapolation** and can result in very poor predictions. Consider the following example.

Example 15

Consider again the data set from the previous problem:

Time, t , in weeks	0	1	2	3	4	5
Weight, W , in pounds	196	192	193	190	190	186

Would it be reasonable to use your regression equation to predict the weight in pounds after 100 weeks? Why or why not?

Recall, the regression equation for this data set was

$$W = -1.69t + 195.38$$

Our model was created based off of data from 0 to 5 weeks into a weight loss program. Is it reasonable to assume that the same pattern of weight loss that held in weeks 0-5 would be present in week 100? It certainly doesn't seem so. This is an example of extrapolation. Let's see what would happen if we tried to use the model to predict the weight in pounds after 100 weeks. We plug in $t = 100$ to the regression equation, and solve for W .

$$W = -1.69(100) + 195.38$$

$$W = 26 \text{ pounds}$$

If this pattern of weight loss continued, the individual would weigh only 26 pounds after 100 weeks! This is not likely to be an accurate prediction.

You Try 3.3C

The following table gives the total number of live Christmas trees sold, in millions, in the United States from 2004 to 2011. (Source: Statista.com).

Year	2004	2006	2008	2010	2011
Total Number of Christmas Trees Sold in the U.S. (in millions)	27.10	28.60	28.20	27	30.80

- a) Use your calculator to determine the equation of the *regression line*, $C(t)$ where t represents the number of years since 2004.

Start by entering new t values for the table below based upon the number of years since 2004. The first few are done for you:

$t =$ number of years since 2004	0	2			
$C(t) =$ Total number of Christmas trees sold in the U.S. (in millions)	27.10	28.60	28.20	27	30.80

- b) Identify the slope of the regression equation and explain its meaning in the context of this problem.
- c) Use the regression equation to predict the number of Christmas trees that will be sold in the year 2013. Write your answer as a complete sentence.
- d) Should you use your regression equation to predict the number of Christmas trees that will be sold in the year 2030? Why or why not?

Section 3.4 – Correlation

In the last section we learned about relationships between two variables that appeared to be linear. In some cases, the scatterplot shows very clearly that the two variables are linearly related, but in many cases it can be a bit challenging to tell exactly how strong the linear relationship is between the two variables of interest. The **linear correlation (r)**, also called the **correlation coefficient**, is a way to numerically measure the *strength* and the *direction* of the linear relationship between two variables.

Properties of Correlation:

- We use “ r ” to represent the correlation
- $-1 \leq r \leq 1$
- The sign of r indicates the direction of the linear relationship between the 2 variables
 - If $r < 0$, there is a negative linear relationship between the 2 variables (slope of the regression equation is negative).
 - If $r > 0$, there is a positive linear relationship between the 2 variables (slope of the regression equation is positive).
- The magnitude of r indicates the strength of the linear relationship between the 2 variables
 - If $r \approx 0$, then there is no linear relationship between the 2 variables
 - If $|r| \approx 1$, then there is a very strong linear relationship between the 2 variables
 - If $r = 1$ or -1 , then there is an exact linear relationship between the 2 variables (every data point falls exactly on the regression line)

These properties of correlation can be summarized in the graphic below:

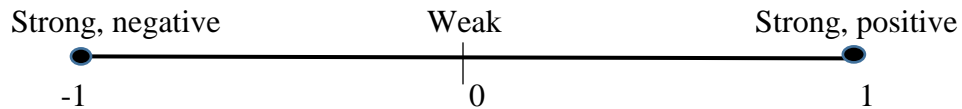

Example 16

Consider the following scatterplots, and their corresponding correlation values.

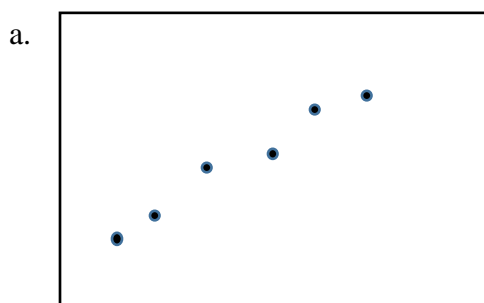

$$r = 0.94$$

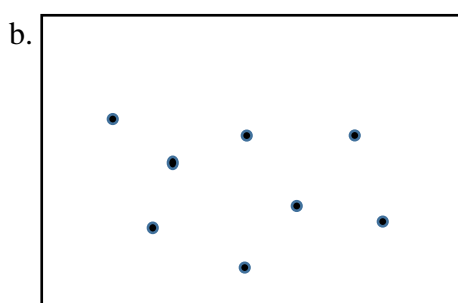

$$r = -0.15$$



$$r = -0.88$$

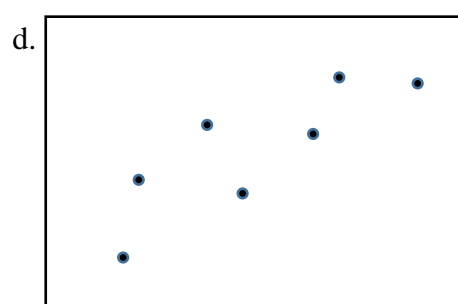

$$r = 0.58$$

Classify the strength and direction of the linear relationship between the 2 variables in each scatterplot

- Here $r = 0.94$, which is close to positive 1. We would say these 2 variables have a strong, positive linear relationship.
- Here $r = -0.15$, which is negative and close to 0. We could say these 2 variables have a very weak, negative linear relationship.
- Here $r = -0.88$, which is close to negative 1. We would say these 2 variables have a strong, negative linear relationship.
- Here $r = 0.58$, which is positive, but not particularly close to 0 or 1. We would say these 2 variables have a moderate, positive linear relationship.

Note: There is no “cutoff” value for which values of r are considered “strong” and which are considered “weak”. The interpretation of r can be fairly subjective. What you should know is that the farther the value of r is from 0, the stronger the linear relationship between the 2 variables is considered to be.

Now that we have a basic understanding of interpreting the correlation, we can discuss how to find it. As with linear regression, the calculations for finding correlation by hand are rather time consuming. We will again rely on the graphing calculator to find the correlation for us.

Example 17

Consider again the data set from the weight loss problem:

Time, t , in weeks	0	1	2	3	4	5
Weight, W , in pounds	196	192	193	190	190	186

- Use your graphing calculator to find the correlation between time and weight.
- Interpret the meaning of the correlation you found in part a.

To find the correlation on the graphing calculator, press the “2nd” key and then “Catalog”. “Catalog” is a 2nd function on the zero key. Use the arrow keys to scroll down to “DiagnosticOn”. Hit ENTER. On the main screen, your calculator should display DiagnosticOn followed by a blinking cursor. Hit ENTER. The calculator should display “Done”. Once you have turned on the DiagnosticON, you do not have to do it again. Also, it will not interfere with any other calculator functions, so you can just leave it on.

Once you have turned on “DiagnosticOn” you can follow the instructions for finding the linear regression equation from section 3.3. When the calculator displays the linear regression equation, it will also display the correlation value, r .

- Enter your data into L1 and L2, then press STAT, scroll over to CALC, and select option 4: LinReg(ax+b). Your output should consist of the values of a and b (just like we did in section 3.3) AND two new values: r^2 and r . The value of $r = -0.94$. (NOTE: The quantity r^2 is the coefficient of determination, which we do not cover in this course).
- The value of $r = -0.94$. This means that time and weight have a strong, negative linear relationship. This means that as time increases, weight tends to decrease. This can be confirmed by a scatterplot of the data which showed a negative slope to the data points.

You Try 3.4

Recall, the following table gives the total number of live Christmas trees sold, in millions, in the United States from 2004 to 2011. (Source: Statista.com).

t = number of years since 2004	0	2	4	6	7
$C(t)$ = Total Number of Christmas Trees Sold in the U.S. (in millions)	27.10	28.60	28.20	27	30.80

- Use your graphing calculator to find the numerical value of the correlation.
- Interpret the meaning of the correlation from part a).

Chapter 3 – Answers to You Try Problems

3.1A a. 51 b. 0

3.1B a. 0 b. 0 or 2

3.1C a. 28 b. -3

3.2A $V(n) = 2300 - 250n$, where $V(n)$ gives the value (in dollars) of the TV after n years.

3.2B The surface elevation of Lake Powell is decreasing at a rate of 78 feet per year.

3.2C Your College account starts with \$20,000 in it and you withdraw \$4,000 each quarter (or your account contains \$20,000 and decreases by \$4000 each quarter.) You can pay for 5 quarters before the money in this account is gone.

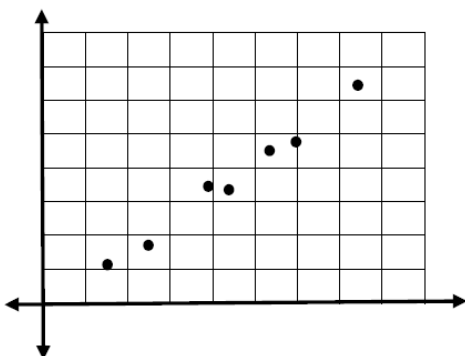
3.2D a. 696 students b. 4 years c. 174 students per year d. $P(t) = 174t + 1001$
e. 2219 students3.3A
a.

b. Increasing

c. Yes, there appears to be a linear trend

3.3B $y = 0.32x + 24.16$ 3.3C a. $C(t) = 0.279t + 27.28$ b. For each additional year since 2004, the number of Christmas trees sold in the U.S. will increase by approximately 279,000 trees.
c. 29.79 million Christmas trees
d. No. The original data is for years 2004 through 2011. The year 2030 is too far from the original data set.3.4 a. $r = 0.52$ b. There is a moderate, positive linear relationship between the time in years since 2004 and the number of Christmas trees sold in the U.S.

Chapter 3 - Practice Problems

1. A function $P(n)$ gives the wholesale price in dollars of a package of cookies after n packages have been sold. Interpret the meaning of $P(124) = 0.8$.
2. The function $C(g)$ represents the cost to produce g gallons of chocolate chunk ice cream. Interpret the meaning of $C(751) = 160$.
3. The function $D(t)$ can be used to approximate the total average credit card debt in a U.S. household (in thousands of dollars) t years after 1995. Interpret the meaning of $D(29) = 21.5$.
4. A function $d(h)$ gives the number of miles Billy has driven in his car from his house h hours after leaving his house.
 - a. Interpret $d(4) = 160$
 - b. Interpret $d(0.1) = 2$
5. The function $g(t)$ is given by the table below.

t	0	1	2	3	4	5	6
$g(t)$	12	24	3	24	27	0	3

- a. Evaluate $g(1)$
 - b. Evaluate $g(6)$
 - c. Determine t when $g(t) = 24$
6. The function $f(x)$ is represented below as a graph. Use $f(x)$ to answer the following questions:

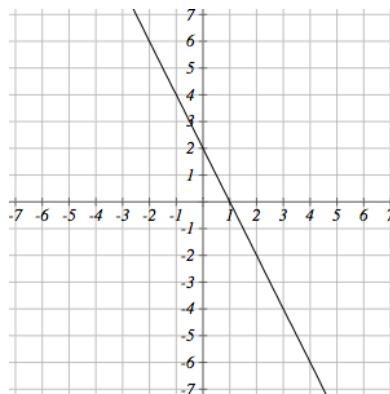

- a. Evaluate $f(-1)$
- b. Evaluate $f(3)$
- c. Determine x when $f(x) = 0$
- d. Determine x when $f(x) = 6$

7. The function $f(x)$ is represented below as a graph. Use $f(x)$ to answer the following questions:

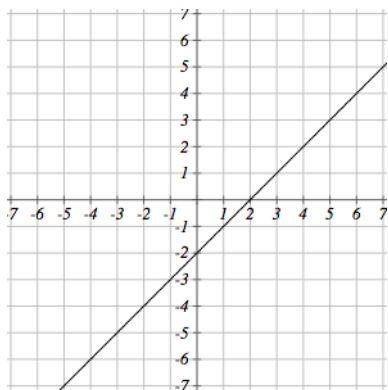

- a. Evaluate $f(0)$
 - b. Evaluate $f(4)$
 - c. Determine x when $f(x) = -3$
 - d. Determine x when $f(x) = 1$
8. Given the function $g(x) = x + 2$
- a. Evaluate $g(-5)$
 - b. Evaluate $g(0)$
 - c. Determine x when $g(x) = -2$
9. Given the function $k(t) = -8t + 9$
- a. Evaluate $k(3)$
 - b. Evaluate $k(0)$
 - c. Determine t when $k(t) = -39$
10. Identify the rate of change and initial value for the function $f(x) = 3x + 7$
11. Identify the rate of change and initial value for the function $f(x) = -9 - 10x$
12. Identify the rate of change and initial value for the function $f(x) = -5x$
13. Identify the rate of change and initial value for the function $f(x) = 1$
14. Calculate the rate of change of the linear function that contains the points $(1, 8)$ and $(4, 17)$.
15. Calculate the rate of change of the linear function that contains the points $(-15, 30)$ and $(7, -14)$.
16. Calculate the rate of change of the linear function that contains the points $(3, 2)$ and $(10, 2)$.

17. Determine the rate of change and initial value of the linear function that generates the following table of values.

x	-4	-3	-2	-1	0	1	2	3	4
$f(x)$	-70	-49	-28	-7	14	35	56	77	98

18. Determine the rate of change and initial value of the linear function that generates the following table of values.

x	-4	-3	-2	-1	0	1	2	3	4
$f(x)$	102	75	48	21	-6	-33	-60	-87	-114

19. Determine the rate of change and initial value of the linear function that generates the following table of values.

x	-4	-2	0	2	4
$f(x)$	-90	-14	62	138	214

20. The function $V(t) = -5.4t + 34.2$ gives the value (in thousands of dollars) of an investment after t years. Interpret the rate of change in this situation.
21. The function $V(x) = 2.5x + 25.4$ gives the value (in thousands of dollars) of an investment after x months. Interpret the rate of change in this situation.
22. Paul is planning to sell bottled water at the local carnival. Paul's profit (in dollars) from selling b bottles of water is given by the formula $P(b) = 1.4b - 338$. Interpret the rate of change in this situation.
23. When a new charter school opened in 1996, there were 440 students enrolled. Write a formula for the function $N(t)$, representing the number of students attending this charter school t years after 1996, assuming that the student population:
- Increased by 44 students per year
 - Decreased by 32 students per year
 - Remained constant (did not change)
24. A town's population has been growing linearly. In 2003, the population was 59,000 and the population has been growing by 1,700 people each year.
- Write a formula for the population x years after 2003.
 - What will the town's population be in 2007?
 - In what year will the population be 77,700 people?

25. Last year, Pinwheel Industries introduced a new toy. It cost \$1,300 to develop the toy and \$30 to manufacture each toy.
- Write a formula for the total cost to produce n of these toys.
 - What is the total cost to produce 4,400 toys?
 - How many total toys can be produced with \$124,300?
26. In the year 1999, the surface elevation of Lake Powell was 3848 feet above sea level. In the year 2007, the surface elevation of Lake Powell was 3,227.2 feet above sea level. Find the rate of change of the surface elevation during this time span.
27. In the year 1987, an investment was worth \$29,800. In the year 1997, this investment was worth \$43,800.
- Find the rate of change of the investment during this time span.
 - Is the investment increasing or decreasing?
28. In the year 1982, an investment was worth \$26,200. In the year 1990, this investment was worth \$39,000.
- Find the rate of change of the investment during this time span.
 - Is the investment increasing or decreasing?
29. In 1995, the cost of tuition at a large Midwestern university was \$170 per credit hour. In 2000, tuition had risen to \$235 per credit hour.
- Find the rate of change of the cost of tuition during this time span.
 - Write a formula for the cost of tuition as a function of the number of years since 1990.
 - What will the tuition be in 2007?
 - What year will the tuition be \$417 per credit hour?
30. Robert has \$100 in his school lunch account. If the school charges \$3.50 per lunch, how many lunches can he purchase? How much money will remain in his account?
31. You are interested in starting a gym membership and have narrowed your selection to two gyms. The first, Phoenix Fitness, charges a one-time membership fee of \$99 and charges \$35 per month. The second, Slim Gym, charges a one-time membership fee of \$10 and charges \$40 per month.
- Which gym is the more affordable choice if you are going to commit to a 1-year membership?
 - Which gym is the more affordable choice if you are going to commit to a 2-year membership?

32. a. Use your graphing calculator to create of scatterplot of the data set shown below.

x	1	3	4	6	7	9	10
y	437	901	1155	1358	1768	2103	2437

- b. Does the data set appear to be increasing or decreasing?
c. Does the data set appear to be roughly linear?

33. a. Use your graphing calculator to create of scatterplot of the data set shown below.

x	2	9	14	23	33	42
y	-60.2	-130.1	-243.7	-328.9	-580.5	-643.8

- b. Does the data set appear to be increasing or decreasing?
c. Does the data set appear to be roughly linear?

34. a. Use your graphing calculator to create of scatterplot of the data set shown below.

x	8	12	14	23	24	29	33
y	10	20	15	24	35	30	28

- b. Does the data set appear to be increasing or decreasing?
c. Does the data set appear to be roughly linear?

35. a. Use your graphing calculator to create of scatterplot of the data set shown below.

x	20	24	27	32	48	60	68
y	12	20	28	41	24	15	11

- b. Does the data set appear to be increasing or decreasing?
c. Does the data set appear to be roughly linear?

36. Calculate the linear regression equation for the data from problem 32:

x	1	3	4	6	7	9	10
y	437	901	1155	1358	1768	2103	2437

37. Calculate the linear regression equation for the data from problem 33:

x	2	9	14	23	33	42
y	-60.2	-130.1	-243.7	-328.9	-580.5	-643.8

38. Calculate the linear regression equation for the data from problem 34:

x	8	12	14	23	24	29	33
y	10	20	15	24	35	30	28

39. Consider the following 4 scatterplots. Match each scatterplot with the most appropriate value from the 4 correlations listed below.

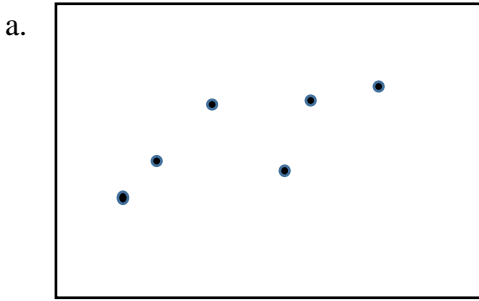

$r = \underline{\hspace{2cm}}$

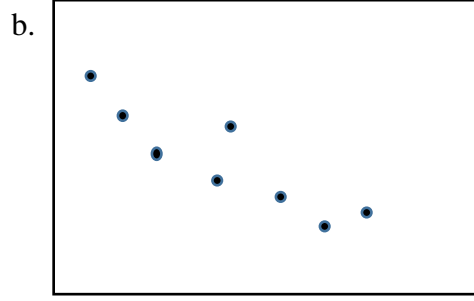

$r = \underline{\hspace{2cm}}$

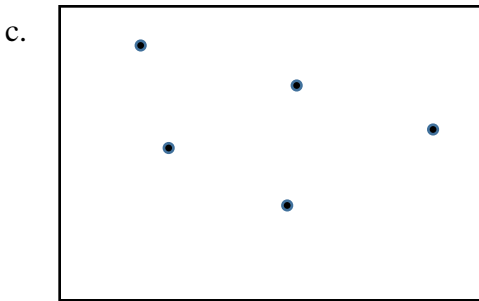

$r = \underline{\hspace{2cm}}$

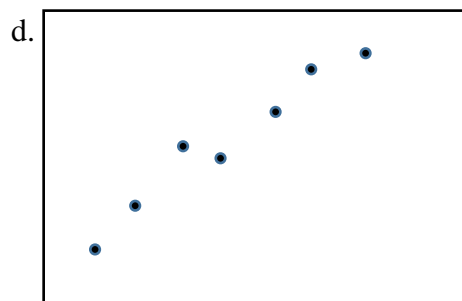

$r = \underline{\hspace{2cm}}$

$r = 0.38$ $r = 0.94$ $r = -0.15$ $r = -0.85$

40. Find and interpret the linear correlation for the data from problem 32:

x	1	3	4	6	7	9	10
y	437	901	1155	1358	1768	2103	2437

41. Find and interpret the linear correlation for the data from problem 33:

x	2	9	14	23	33	42
y	-60.2	-130.1	-243.7	-328.9	-580.5	-643.8

42. Find and interpret the linear correlation for the data from problem 34:

x	8	12	14	23	24	29	33
y	10	20	15	24	35	30	28

43. Find and interpret the linear correlation for the data from problem 35:

x	20	24	27	32	48	60	68
y	12	20	28	41	24	15	11

44. The following table shows the number of newspaper subscriptions in Middletown, USA where t represents the number of years since 2002 ($t = 0$ in 2002) and $S(t)$ represents the total subscriptions each year measured in thousands.

t (year)	0	2	4	6	8
$S(t)$ (total subscriptions in 1000's)	448	372	198	145	45

Find and interpret the linear correlation.

45. Scott is hiking the Appalachian Trail from Georgia to Maine. The distance of his hike is 2200 miles. It took Scott 123 days to complete the hike. The data below represent the distance, D , he had hiked t days after the start of his trip.

t (days hiking)	0	32	47	73	99	123
$D(t)$ (distance in miles)	0	590	912	1212	1876	2200

Find and interpret the linear correlation.

46. Which implies a stronger linear relationship, a correlation of -0.84 or -0.47 ? Explain.

47. Which implies a stronger linear relationship, a correlation of -0.73 or 0.51 ? Explain.

48. The following table shows the number of newspaper subscriptions in Middletown, USA where t represents the number of years since 2002 ($t = 0$ in 2002) and $S(t)$ represents the total subscriptions each year measured in thousands.

t (year)	0	2	4	6	8
$S(t)$ (total subscriptions in 1000's)	448	372	198	145	45

a) Use your graphing calculator to create of scatterplot of the data set.

b) Based on your graph above, do the data appear to be approximately linear?

- c) Use your calculator to determine the *regression equation* in $S(t) = at + b$ form. (Round to 2 decimal places)
- d) What is the slope of your regression model for $S(t)$ and what is its meaning in the context of this problem?
- e) What is the initial value of your linear regression model for $S(t)$ and what is its meaning in the context of the problem.
- f) Use your linear regression equation to estimate the total number of subscriptions in 2007 (i.e. when $t = 5$). Show your computations here and your final result.
- g) Use your linear regression equation to estimate the total number of subscriptions in 2004. How does this value compare to the data value in the table?
- h) Should you use your linear regression equation to estimate the circulation in the year 2030? Why or why not?

49. Scott is hiking the Appalachian Trail from Georgia to Maine. The distance of his hike is 2200 miles. It took Scott 123 days to complete the hike. The data below represent the distance, D , he had hiked t days after the start of his trip.

t (days hiking)	0	32	47	73	99	123
$D(t)$ (distance in miles)	0	590	912	1212	1876	2200

- a) Use your graphing calculator to create of scatterplot of the data set.
- b) Based on your graph above, do the data appear to be approximately linear?
- c) Use your calculator to determine the *regression equation* in $D(t) = at + b$ form. (Round to 2 decimal places)
- d) What is the slope of your regression model for $D(t)$ and what is its meaning in the context of this problem?
- e) Use your linear regression equation to estimate the total number of miles Scott has hiked in 50 days. Show your computations here and your final result.
- f) Should you use your linear regression equation to estimate when Scott has hiked 2500 miles? Why or why not?

Chapter 4: Percentages

Chapter 4 Learning Objectives:

- Convert between fractions, decimals, and percentages
- Solve for part, whole, or percent given any two of the three values
- Calculate and interpret both absolute and relative change
- Find percent increase and percent decrease
- Recognize an exponential function and identify both the growth factor and initial value
- Determine the growth or decay rate from an exponential function
- Model real world problems using exponential functions

Section 4.1 – Percentage Basics

Section 4.2 – Applications Involving Percentages

Section 4.3 – Absolute and Relative Change

Section 4.4 – Percent Increase and Percent Decrease

Section 4.5 – Exponential Functions

Section 4.1 – Percentage Basics

Percent literally means “per 100,” or “parts per hundred.” When we write 40%, this is equivalent to the fraction $\frac{40}{100}$ or the decimal 0.40. Notice that 80 out of 200 and 10 out of 25 are also 40%, since $\frac{80}{200} = \frac{10}{25} = \frac{40}{100}$.

Example 1		
Write each as a percent: a) $\frac{1}{4}$ b) 0.02 c) 2.35		
a) $\frac{1}{4} = 0.25 = 25\%$	b) $0.02 = 2\%$	c) $2.35 = 235\%$

You Try 4.1

Complete the table below.

Fraction	Decimal	Percent
$\frac{3}{5}$		
	0.02	
		72%
	0.025	
$4\frac{1}{2}$		

Section 4.2 – Applications Involving Percentages**Percent**

If we have a *part* that is some *percent* of a *whole*, then

$$\text{percent} = \frac{\text{part}}{\text{whole}}, \text{ or equivalently, } \text{part} = \text{percent} \cdot \text{whole}$$
 To do the calculations, we write the percent as a decimal.

Example 2

243 people out of 400 state that they like dogs. What percent is this?

$$\frac{243}{400} = 0.6075 = \frac{60.75}{100}. \text{ This is } 60.75\%.$$

Notice that the percent can be found from the equivalent decimal by moving the decimal point two places to the right.

You Try 4.2A

To win the election as president of the United States of America, a person must obtain 270 out of 538 possible votes from the electoral college. What percentage of the overall electoral votes is this? Round your answer to the nearest tenth of a percent.

Example 3

The sales tax in a town is 9.4%. How much tax will you pay on a \$140 purchase?

Here, \$140 is the whole, and we want to find 9.4% of \$140. We start by writing the percent as a decimal by moving the decimal point two places to the left (which is equivalent to dividing by 100). We can then compute: Tax = $0.094(140) = \$13.16$

You Try 4.2B

In a recent poll, 28% of the 750 individuals polled indicated that they would vote purely Democratic in the next election. How many of the individuals would vote a straight Democratic ticket?

Example 4

A lender requires a minimum down payment of 12% of the value of the home. You have \$22,020 cash available to use as a down payment toward a home. Determine the maximum home value that you can finance.

To compute the maximum home value, we need to understand what the \$22,020 represents. This is the down payment; we need to find the value of the home. In this case, the down payment is the “part” and the home value is the “whole.” Recall that
part = percent · whole

Let V represent the value of the home. Since we know that the down payment is 12% of the value of the home, we can write the equation: $22,020 = 0.12V$.

Solving this equation for V , we get $V = \frac{22,020}{0.12} = 183,500$

So, with \$22,020 cash available to use as a down payment, you can afford to finance a home worth at most \$183,500.

You Try 4.2C

One banana contains about 425mg of potassium. That is about 13% of the recommended daily amount of potassium. How much potassium should be consumed daily?

When working with percentages, it is very important to understand the quantities being compared. Consider the examples below.

Example 5

In the 2004 vice-presidential debates, Edwards's claimed that US forces have suffered "90% of the coalition casualties" in Iraq. Cheney disputed this, saying that in fact Iraqi security forces and coalition allies "have taken almost 50 percent" of the casualties. Who is correct?

Without more information, it is hard for us to judge who is correct, but we can easily conclude that these two percentages are talking about different things, so one does not necessarily contradict the other. Edward's claim was a percent of *coalition forces*, while Cheney's claim was a percent with *both coalition and Iraqi security forces*. It turns out both statistics are in fact fairly accurate.

Example 6

Over the basketball season, Isaac scores on 40% of 2-point field goal attempts, and on 30% of 3-point of field goal attempts. Find Isaac's overall field goal percentage.

It is very tempting to average these values, and claim the overall average is 35%, but this is likely not correct, since most players make many more 2-point attempts than 3-point attempts. We don't actually have enough information to answer the question. Suppose Isaac attempted 200 2-point field goals and 100 3-point field goals. Then he made $200(0.40) = 80$ 2-point shots and $100(0.30) = 30$ 3-point shots. Overall, Isaac made 110 shots out of 300, for a $\frac{110}{300} = 0.367 = 36.7\%$ overall field goal percentage.

Section 4.3 – Absolute and Relative Change

Oftentimes, percentages are used to compare how a quantity has changed over time. When making this type of comparison, we use absolute change and relative change.

Absolute and Relative Change

Given two quantities,

Absolute change = ending quantity – starting quantity
 Absolute change has the **same units** as the original quantity.

Relative change: $\frac{\text{absolute change}}{\text{starting quantity}}$ (multiply by 100 to write as a %)

Relative change gives a **percent** change.

Example 7

The value of a car dropped from \$7,400 to \$6,800 over the last year. What percent decrease is this?

To compute the percent change, we first need to find the dollar value change:

$$\$6,800 - \$7,400 = -\$600.$$

The **absolute change** is -600.

Since we are computing the decrease relative to the starting value, we compute this percent out of \$7,400:

$$\frac{-600}{7,400} = -0.081 = -8.1\%$$

The value of -8.1% is called a **relative change**.

The fact that it is negative indicates that the value of the car **decreased** over the last year.

Example 8

There are about 75 QFC supermarkets in the U.S. Albertsons has about 215 stores. Compare the size of the two companies.

When we make comparisons, we must ask first whether an absolute or relative comparison. The absolute difference is $215 - 75 = 140$. From this, we could say “Albertsons has 140 more stores than QFC.” However, if you wrote this in an article or paper, that number does not mean much. The relative difference may be more meaningful. There are two different relative changes we could calculate, depending on which store we use as the base:

$$\text{Using QFC as the base, } \frac{140}{75} = 1.867.$$

This tells us Albertsons is 186.7% larger than QFC.

$$\text{Using Albertsons as the base, } \frac{140}{215} = 0.651.$$

This tells us QFC is 65.1% smaller than Albertsons.

Notice both of these are showing percent *differences*. We could also calculate the size of Albertsons relative to QFC: $\frac{215}{75} = 2.867$, which tells us Albertsons is 2.867 times the size of QFC.

Likewise, we could calculate the size of QFC relative to Albertsons: $\frac{75}{215} = 0.349$, which tells us that QFC is 34.9% of the size of Albertsons.

Example 9

Suppose a stock drops in value by 60% one week, then increases in value the next week by 75%. Is the value higher or lower than where it started?

To answer this question, suppose the value started at \$100. After one week, the value dropped by 60%:

$$\$100 - \$100(0.60) = \$100 - \$60 = \$40.$$

In the next week, notice that base of the percent has changed to the new value, \$40. Computing the 75% increase:

$$\$40 + \$40(0.75) = \$40 + \$30 = \$70.$$

In the end, the stock is still \$30 lower, or $\frac{\$30}{\$100} = 30\%$ lower, valued than it started.

You Try 4.3

The U.S. federal debt at the end of 2001 was \$5.77 trillion, and grew to \$6.20 trillion by the end of 2002. At the end of 2005 it was \$7.91 trillion, and grew to \$8.45 trillion by the end of 2006⁴. Calculate the absolute and relative increase for 2001-2002 and 2005-2006. Which year saw a larger increase in federal debt?

Example 10

A Seattle Times article on high school graduation rates reported “The number of schools graduating 60 percent or fewer students in four years – sometimes referred to as “dropout factories” – decreased by 17 during that time period. The number of kids attending schools with such low graduation rates was cut in half.”

- Is the “decrease by 17” number a useful comparison?
- Considering the last sentence, can we conclude that the number of “dropout factories” was originally 34?

⁴ <http://www.whitehouse.gov/sites/default/files/omb/budget/fy2013/assets/hist07z1.xls>

- a) This number is hard to evaluate, since we have no basis for judging whether this is a larger or small change. If the number of “dropout factories” dropped from 20 to 3, that’d be a very significant change, but if the number dropped from 217 to 200, that’d be less of an improvement.
- b) The last sentence provides relative change which helps put the first sentence in perspective. We can estimate that the number of “dropout factories” was probably previously around 34. However, it’s possible that students simply moved schools rather than the school improving, so that estimate might not be fully accurate.

Example 11

A politician’s support increases from 40% of voters to 50% of voters. Describe the change.

When talking about a change of quantities that are already measured in percentages, we have to be careful in how we describe the change.

We could describe this using an absolute change: $|50\% - 40\%| = 10\%$. Notice that since the original quantities were percents, this change also has the units of percent. In this case, it is best to describe this as an increase of 10 **percentage points**.

In contrast, we could compute the percent change: $\frac{10\%}{40\%} = 0.25 = 25\%$ increase. This is the relative change, and we’d say the politician’s support has increased by 25%.

Section 4.4 – Percent Increase and Percent Decrease

In the previous section, we calculated the relative, or percent, change. Now, we will use the idea of percent change to determine the future value of the quantity.

Example 12

In the news, you hear “tuition is expected to increase by 7% next year.” If tuition this year was \$1,200 per quarter, what will it be next year?

There are a couple of ways to approach this problem:

1. The tuition next year will be the current tuition plus an additional 7%, so it will be $100\% + 7\% = 107\%$ of this year’s tuition. Calculate 107% of \$1,200:

$$\$1,200(1.07) = \$1,284.$$
2. Alternatively, we could have first calculated 7% of \$1,200: $\$1,200(0.07) = \$84.$

Notice this is NOT the expected tuition for next year (we could only wish). Instead, this is the expected increase, so to calculate the expected tuition, we'll need to add this change to the previous year's tuition: $\$1200 + \$84 = \$1,284$.

Example 13

A TV originally priced at \$869 is on sale for 35% off. Determine the sale price of the TV.

There are a couple of ways to approach this problem:

1. After the discount, you will wind up paying $100\% - 35\% = 65\%$ of the original price of the item. Calculate 65% of the original price to find the sale price:

$$\$869(0.65) = \$564.85.$$
2. Alternatively, we could have first calculated 35% of \$869: $\$869(0.35) = \304.15 . *Notice this is the amount of the discount, NOT the sale price!* So, to calculate the sale price, we will need to subtract discount from the original price of the item:

$$\$869 - \$304.15 = \$564.85.$$

You Try 4.4

- a. The bill for dinner (after tax) was \$85.20. You decide to leave a 15% tip. Calculate the total amount paid.
- b. A clothing store is having a 15% off sale. Determine the sale price for an item that was originally priced at \$74

Example 14

You purchased a new phone in Scottsdale, which has 7.95% sales tax. The total cost (including tax) for your new phone was \$505.40. What was the pre-tax price?

To compute the pre-tax price, we need to understand what the \$505.40 represents. Since \$505.40 is the total cost including tax, we know:

$$\text{Cost of phone} + \text{tax} = \$505.40$$

We know the dollar amount of tax is 7.95% of the cost of the phone, or $0.0795(\text{cost of phone})$. If we call the cost of the phone C , we can write the equation:

$$\begin{array}{ll} C + 0.0795C = 505.40 & \text{Combine like terms} \\ 1.0795C = 505.40 & \text{Divide to solve for } C \end{array}$$

$$C = \$468.18 \quad \text{The pre-tax cost of the phone was } \$468.18.$$

Section 4.5 – Exponential Functions

India is the second most populous country in the world, with a population in 2008 of about 1.14 billion people. The population is growing by about 1.34% each year⁵. We might ask if we can find a formula to model the population, P , as a function of time, t , in years after 2008, if the population continues to grow at this rate.

In **linear growth**, we had a constant rate of change – a constant *number* that the output increased for each increase in input. For example, in the equation $f(x) = 3x + 4$, the slope tells us the output increases by three each time the input increases by one.

This population scenario is different – we have a *percent* rate of change rather than a constant number of people as our rate of change.

To see the significance of this difference consider these two companies:

- Company A has 100 stores, and expands by opening 50 new stores a year
- Company B has 100 stores, and expands by increasing the number of stores by 50% of their total each year.

Looking at a few years of growth for these companies:

Year	Stores, company A	Stores, company B	
0	100	100	Starting with 100 each
1	$100 + 50 = 150$	$100 + 50\% \text{ of } 100$ $100 + 0.50(100) = 150$	They both grow by 50 stores in the first year.
2	$150 + 50 = 200$	$150 + 50\% \text{ of } 150$ $150 + 0.50(150) = 225$	Store A grows by 50, Store B grows by 75
3	$200 + 50 = 250$	$225 + 50\% \text{ of } 225$ $225 + 0.50(225) = 337.5$	Store A grows by 50, Store B grows by 112.5

Notice that with the percent growth, each year the company grows by 50% of the current year's total, so as the company grows larger, **the number of stores added** in a year grows as well. To try to simplify the calculations, notice that after 1 year the number of stores for company B was: $100 + 0.50(100)$ or equivalently by factoring $100(1 + 0.50) = 150$. We can think of this as “the new number of stores is the original 100% plus another 50%”.

After 2 years, the number of stores was:

$$150 + 0.50(150) \quad \text{or equivalently by factoring}$$

$$150(1 + 0.50) \quad \text{now recall the 150 came from } 100(1 + 0.50). \text{ Substituting that,}$$

$$100(1 + 0.50)(1 + 0.50) = 100(1 + 0.50)^2 = 225$$

⁵ World Bank, World Development Indicators, as reported on <http://www.google.com/publicdata>, retrieved August 20, 2010

After 3 years, the number of stores was:

$$225 + 0.50(225) \quad \text{or equivalently by factoring}$$

$$225(1 + 0.50) \quad \text{now recall the 225 came from } 100(1 + 0.50)^2. \text{ Substituting that,}$$

$$100(1 + 0.50)^2(1 + 0.50) = 100(1 + 0.50)^3 = 337.5$$

From this, we can generalize, noticing that to show a 50% increase, each year we multiply by a factor of $(1+0.50)$, so after n years, our equation would be:

$$B(n) = 100(1+0.50)^n$$

In this equation, the 100 represented the initial quantity, and the 0.50 was the percent growth rate. Generalizing further, we arrive at the general form of exponential functions.

An **exponential growth or decay function** is a function that grows or shrinks at a constant percent growth rate. An exponential function has the form $f(x) = ab^x$ where

a is the initial or starting value of the function

b is the growth factor (or decay factor)

If $b > 1$, then the function is increasing (growth).

If $0 < b < 1$, then the function is decreasing (decay).

If r is the percent growth or decay rate (in decimal form), the exponential function can be written as follows: Growth: $f(x) = a(1 + r)^x$ or Decay: $f(x) = a(1 - r)^x$

To see more clearly the difference between exponential and linear growth, compare the two tables and graphs below, which illustrate the growth of company A and B described above over a longer time frame if the growth patterns were to continue.

years	Company A	Company B
2	200	225
4	300	506
6	400	1139
8	500	2563
10	600	5767

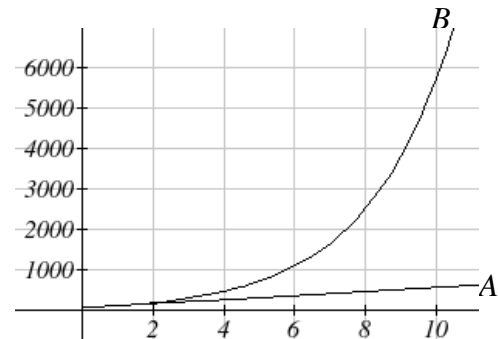

Example 15

Complete the table below.

Function	Initial Value	Growth or Decay	Rate (as a %)
$f(x) = 430(1.15)^x$			
$f(x) = 23(0.8)^x$			
	1.87	Growth	5%
	52	Decay	10%

Function	Initial Value	Growth or Decay	Rate (as a %)
$f(x) = 430(1.15)^x$	430	Growth	$1.15 - 1 = 0.15$ Growth Rate: 15%
$f(x) = 23(0.8)^x$	23	Decay	$1 - 0.8 = 0.2$ Decay Rate = 20%
$f(x) = 1.87(1 + 0.05)^x$ $f(x) = 1.87(1.05)^x$	1.87	Growth	5%
$f(x) = 52(1 - 0.10)^x$ $f(x) = 52(0.9)^x$	52	Decay	10%

Example 16

$T(q)$ represents the total number of Android smart phone contracts, in thousands, held by a certain Verizon store region measured q quarters since January 1, 2010.

Interpret all of the parts of the equation $T(2) = 86(1.64)^2 = 231.3056$.

Interpreting this from the basic exponential form, we know that **86 is our initial value**. This means that on Jan. 1, 2010 this region had 86,000 Android smart phone contracts.

Since $b = 1 + r = 1.64$, we know that every quarter the number of smart phone contracts **grows by 64%**.

$T(2) = 231.3056$ means that in the 2nd quarter (or at the end of the second quarter) there were approximately 231,306 Android smart phone contracts.

You Try 4.5A

- a. Given the three statements below, identify which represent exponential functions.
1. The cost of living allowance for state employees increases salaries by 3.1% each year
 2. The value of an investment is increasing by \$300 each year
 3. Tuition costs have increased by 2.8% each year for the last 3 years.
- b. Looking at the following two equations that represent the balance in two different savings accounts, which account is growing faster, and which account will have a higher balance after 3 years?

$$A(t) = 1,000(1.05)^t \qquad B(t) = 900(1.075)^t$$

- c. Complete the table. The first one has been done for you.

Function	Initial Value	Growth or Decay	Rate (as a %)
$f(x) = 615(0.79)^x$	615	Decay	21%
$f(x) = 500(1.03)^x$			
$f(x) = 3,200(1.2)^x$			
$f(x) = 19,611(0.98)^x$			
	50	Growth	12%
	377	Decay	8%

Example 17

In the year 2008, India's population was 1.14 billion and growing at a rate of 1.34% per year. Write an exponential function for India's population, and use it to predict the population in 2020.

Using 2008 as our starting time ($t = 0$), our initial population will be 1.14 billion. Since the percent growth rate was 1.34%, our value for r is 0.0134. Using the basic formula for exponential growth $f(x) = a(1 + r)^x$ we can write the formula,

$$P(t) = 1.14(1 + 0.0134)^t = 1.14(1.0134)^t,$$

where $P(t)$ is the population of India (measured in billions) t years after 2008.

To estimate the population in 2020, we evaluate the function at $t = 12$, since 2020 is 12 years after 2008.

$$P(12) = 1.14(1.0134)^{12} \approx 1.337 \text{ billion people in 2020}$$

Example 18

Bismuth-210 is an isotope that radioactively decays by about 13% each day, meaning 13% of the remaining Bismuth-210 transforms into another atom (polonium-210 in this case) each day. If you begin with 100 mg of Bismuth-210, how much remains after one week?

With radioactive decay, instead of the quantity increasing at a percent rate, the quantity is decreasing at a percent rate. Our initial quantity is $a = 100$ mg, and our decay rate is 13%, so $r = 0.13$.

This gives the equation: $Q(d) = 100(1 - 0.13)^d = 100(0.87)^d$ where $Q(d)$ is the amount (in mg) of Bismuth-210 remaining after d days.

This can also be explained by recognizing that if 13% decays, then 87% remains.

After one week, 7 days, the quantity remaining would be
 $Q(7) = 100(0.87)^7 = 37.73$ mg of Bismuth-210 remains.

Example 19

An investment is initially worth \$10,000. Write a formula for the value of this investment for each situation described below.

- The value increases by 5% every year.
- The value increases by 5% every 3 years.
- The value increases by 5% every 6 months.

In this problem, we are looking for three exponential functions of the form $V(t) = ab^t$, where $V(t)$ represents the value of the investment (in dollars) after t years. Since the initial value is \$10,000, we know that $a = 10,000$. In each case, the value of the investment is increasing by 5%, so $b = 1 + 0.05 = 1.05$. The only difference in these three cases is the *time period* for which the 5% increase occurs.

- a) Since the 5% increase occurs every year, we have $V(t) = 10,000(1.05)^t$

t	$V(t) = 10000(1.05)^t$
0	$10000(1.05)^0 = 10,000$
1	$10000(1.05)^1 = 10,500$
2	$10000(1.05)^2 = 11,025$
3	$10000(1.05)^3 = 11,576$

- b) Since the 5% increase occurs every three years, we need to multiply by the growth factor, 1.05, only every three years. When $t = 3$ we multiply by the growth factor once. If $t = 6$, we multiply by the growth factor twice, and so on. The formula would then be $V(t) = 10,000(1.05)^{t/3}$

t	$V(t) = 10000(1.05)^{t/3}$
0	$10000(1.05)^{0/3} = 10000(1.05)^0 = 10,000$
3	$10000(1.05)^{3/3} = 10000(1.05)^1 = 10,500$
6	$10000(1.05)^{6/3} = 10000(1.05)^2 = 11,025$
9	$10000(1.05)^{9/3} = 10000(1.05)^3 = 11,576$

- c) Since the 5% increase occurs every six months, or twice each year, we need to multiply by the growth factor, 1.05, *two times* each year. The formula would then be $V(t) = 10,000(1.05)^{2t}$

t	$V(t) = 10000(1.05)^{2t}$
0	$10000(1.05)^{2(0)} = 10000(1.05)^0 = 10,000$
1/2	$10000(1.05)^{2(1/2)} = 10000(1.05)^1 = 10,500$
1	$10000(1.05)^{2(1)} = 10000(1.05)^2 = 11,025$
3/2	$10000(1.05)^{2(3/2)} = 10000(1.05)^3 = 11,576$

To verify that these formulas are correct, we can compare the following tables of values:

a) Every year

t	$V(t) = 10000(1.05)^t$
0	10,000
1	10,500
2	11,025
3	11,576
4	12,155
5	12,763
6	13,401

b) Every 3 years

t	$V(t) = 10000(1.05)^{t/3}$
0	10,000
1	10164
2	10331
3	10,500
4	10672
5	10847
6	11,025

c) Every 6 months

t	$V(t) = 10000(1.05)^{2t}$
0	10,000
0.5	10,500
1	11,025
1.5	11,576
2	12,155
2.5	12,763
3	13,401

Example 20

Consider the following situations:

- The population of a town is 83.6 thousand in the year 2005 and grows at a rate of 11.5% every 8 years.
- A company's sales are \$14.2 million at the beginning of 2011, and have been decreasing at a rate of about 3.2% per quarter.

Write a formula for each of these situations using time, *in years*, as the input quantity

- In this situation, let $P(t)$ represent the population of the town (in thousands) t years after 2005. Since the population is increasing at a rate of 14% *every 8 years*, the formula would then be:

$$P(t) = 83.6(1 + 0.115)^{t/8}$$

$$P(t) = 83.6(1.115)^{t/8}$$

- In this situation, let $S(t)$ represent the sales (in millions of dollars) t years after 2011. Since sales are decreasing at a rate of 3.2% *per quarter, or 4 times each year*, the formula for $S(t)$ would then be:

$$S(t) = 14.2(1 - 0.032)^{4t}$$

$$S(t) = 14.2(0.968)^{4t}$$

You Try 4.5B

An investment is initially worth \$84,300. Write a formula for the function $V(t)$, representing the value of this investment after t years in each of the following situations.

- The value increases by 6.5% every year.
- The value decreases by 3% every year.
- The value increases by \$600 every year.
- The value decreases by \$1400 every year.
- The value increases by 26% every 2 years.
- The value decreases by 13% every month.

Chapter 4 – Answers to You Try Problems

4.1

$\frac{3}{5}$	0.6	60%
$\frac{2}{100} = \frac{1}{50}$	0.02	2%
$\frac{72}{100} = \frac{18}{25}$	0.72	72%
$\frac{25}{1000} = \frac{1}{40}$	0.025	2.5%
$4\frac{1}{2}$	4.5	450%

4.2A 50.2%

4.2B 210

4.2C 3,269mg, or 3.269 g

4.3 2001-2002: Absolute Change=\$0.43 trillion Relative Change = 7.45% increase
 2005-2006: Absolute Change=\$0.54 trillion Relative Change = 6.83% increase
 2005-2006 saw a larger absolute increase, but a smaller relative increase.

4.4 a. \$97.98

b. \$62.90

- 4.5A a. 1 & 3 are exponential functions; they grow by a % not a constant number.
 b. B(t) is growing faster, but after 3 years A(t) still has a higher account balance
 c.

$f(x) = 500(1.03)^x$	500	Growth	3%
$f(x) = 3,200(1.2)^x$	3,200	Growth	20%
$f(x) = 19,611(0.98)^x$	19,611	Decay	2%
$f(x) = 50(1.12)^x$	50	Growth	12%
$f(x) = 377(0.92)^x$	377	Decay	8%

- 4.5B a. $V(t) = 84,300(1.065)^t$
 b. $V(t) = 84,300(0.97)^t$
 c. $V(t) = 84,300 + 600t$
 d. $V(t) = 84,300 - 1,400t$
 e. $V(t) = 84,300(1.26)^{t/2}$
 f. $V(t) = 84,300(0.87)^{12t}$

Chapter 4 - Practice Problems

- Write each as a percent:
 - $\frac{3}{4}$
 - $\frac{4}{5}$
 - $\frac{7}{10}$
- The fraction $\frac{5}{7}$ is equivalent to what percent? Round your answer to the nearest tenth of a percent.
- The fraction $\frac{7}{9}$ is equivalent to what percent? Round your answer to the nearest tenth of a percent.
- The fraction $\frac{2}{11}$ is equivalent to what percent? Round your answer to the nearest tenth of a percent.
- Write each as a percent:
 - 0.23
 - 0.215
 - 1.09
- Write each as a decimal:
 - 15%
 - 4%
 - 7.5%
- 20% is equivalent to what fraction in reduced terms?
- 86% is equivalent to what fraction in reduced terms?
- 58% is equivalent to what fraction in reduced terms?
- What number is 70% of 40?
- What number is 45% of 155?
- 105 is what percent of 225?
- 170 is what percent of 245?
- 18 is 30% of what number?
- 130 is 65% of what number?

16. Valerie paid \$170 for an item that was originally priced at \$550. What percent of the original price did Valerie pay? Round your answer to the nearest tenth of a percent.
17. Trader Joe's sold 8,132 bags of tortilla chips last month. If 7,687 of these bags were fat free, find the percent that were fat free. Round your answer to the nearest percent.
18. 76% of the questions on a student's test were correct. There were 50 questions. How many of the questions were correct?
19. At a restaurant, the bill comes to \$35. If you decide to leave a 15% tip, how much is the tip? Round your answer to the nearest cent.
20. What is the sales tax on a suit priced at \$295 if the sales tax is 7%?
21. What is the sales tax on a suit priced at \$1266 if the sales tax is 6%?
22. A lender requires a minimum down payment of 16% of the value of the home. You have \$39,000 cash available to use as a down payment toward a home. Determine the maximum home value that you can finance.
23. The population of a town increased from 3,850 in 2005 to 5,900 in 2012. By what percent did the population increase?
24. The price of a latte dropped from \$3.12 to \$3.00. Find the absolute change and relative change of the price of a latte.
25. Theresa's annual income increased from \$31,000 to \$48,000. Find the absolute change and relative change of Joe's annual income.
26. A shirt that was originally marked as \$24.95 rings up at the register as \$19.96. What is the percent discount on the shirt?
27. The U.S. Weather Bureau has a station on Mauna Loa in Hawaii that has measured carbon dioxide levels since 1959. At that time, there were 307 parts per million of carbon dioxide in the atmosphere. In 2005, the figure was 391 parts per million. Find the increase in carbon dioxide levels and the percent of increase. Round to the nearest tenth of a percent.
28. Anthony and his son Johnny are exercising more regularly and keeping track of their weight loss. Both Anthony and Johnny lost 10 pounds.
 - a. From this information alone, can you determine if they both lost the same percentage of weight?
 - b. Suppose Anthony's starting weight is 190 pounds and Johnny's starting weight is 155. Who lost a larger percent of their starting weight?

29. A company calls to notify you that the interest rate on your credit card will increase from 16% to 18%.
- Determine the number of percentage points the interest rate increased by.
 - Determine the percent increase of the interest rate.
30. The sales tax rate for the state of Washington was 5.7%. If the sticker price of a car in Washington is \$4,100, what will be the final cost of the car, including tax?
31. A store is having a 35% off sale. If the original price of the shirt is \$18.00, what is the price of the shirt after the discount is applied (not including tax)?
32. Hank currently makes \$13.00 per hour and is going to receive a 7% raise. What will be Hank's new hourly wage?
33. At a restaurant, the bill comes to \$50. If you decide to leave a 15% tip, what is the total amount you paid?
34. At a restaurant, the bill comes to \$32.20. If you decide to leave an 18% tip, what is the total amount you paid?
35. Sam lost 11% of his body weight after including healthier foods in his diet and exercising regularly. If his original weight was 218 lbs, what is his current weight?
36. A sales clerk received an increase in her annual salary, which is now \$27,300. If she received a 5% raise, what was her starting salary? Round your answer to the nearest cent.
37. Joyce paid \$84.50 for an item at the store that was 35% off the original price. What was the original price? Round your answer to the nearest cent.
38. You purchased a new car for a total cost of \$19,241.94, which includes the 13% sales tax. What was the original price of the car? Round your answer to the nearest cent.
39. Given the function $f(x) = 24(0.72)^x$, evaluate the following.
- $f(-3)$
 - $f(0)$
 - $f(2)$
40. Given the function $f(x) = 5(1.08)^x$, evaluate the following.
- $f(-1)$
 - $f(0)$
 - $f(3)$
41. For the function $f(x) = 170(0.8)^x$
- Identify the initial value
 - Identify the functions behavior as growth or decay
 - Identify the growth/decay factor
 - Identify the growth/decay rate (as a percent)

42. For the function $f(x) = 5(2)^x$
- Identify the initial value
 - Identify the functions behavior as growth or decay
 - Identify the growth/decay factor
 - Identify the growth/decay rate (as a percent)
43. For the function $h(t) = 110(1.3)^t$
- Identify the initial value
 - Identify the functions behavior as growth or decay
 - Identify the growth/decay factor
 - Identify the growth/decay rate (as a percent)
44. For the function $f(x) = 60(0.7)^x$
- Identify the initial value
 - Identify the functions behavior as growth or decay
 - Identify the growth/decay factor
 - Identify the growth/decay rate (as a percent)
45. Write the exponential function with an initial value of 110 and a growth rate of 3.5%.
46. Write the exponential function with an initial value of 1504 and a growth rate of 12%.
47. Write the exponential function with an initial value of 63 and a decay rate of 28%.
48. Write the exponential function with an initial value of 545 and a decay rate of 0.4%.
49. Write the exponential function with an initial value of 79 and a growth rate of 119%.
50. Given the three statements below, identify which represent exponential functions.
- The number of pennies in your piggy bank doubles every year.
 - The value of a car depreciates at a rate of 22% per year.
 - The temperature is decreasing at the rate of 3°F per hour.
51. When a new charter school opened in 2010, there were 970 students enrolled. Using function notation, write a formula representing the number of students attending this charter school t years after 2010, assuming that the student population:
- Increases by 73 students per year
 - Decreases by 36 students per year
 - Decreases by 9.4% per year
 - Increases by 6.1% per year
 - Remains constant (does not change)
52. A population numbers 1,944 organisms initially and increases by 5.2% each year.
- Write an exponential function for the population of the organisms.
 - Predict the number of organisms after 7 years.

53. A population numbers 17,000 organisms initially and decreases by 8% each year.
- Write an exponential function for the population of the organisms.
 - Predict the number of organisms after 2 years.
54. In 2014 Rose invested \$16,000 in a savings account for her newborn son. The account pays 3.6% interest each year. Determine the total value of the account in the year 2032, when her son will go to college. Round your answer the nearest cent.
55. You have saved \$1,000 to invest in a savings account. Write an exponential function for the value of this investment for each situation that follows:
- The value increases by 4% every year.
 - The value increases by 4% every 2 years.
 - The value increases by 4% every 6 months.
 - The value increases by 4 % every 3 months.
56. An investment is initially worth \$7,400. Write an exponential function representing the value of this investment after t years in each of the following situations.
- The value increases by 3.6% every year.
 - The value decreases by 2% every year.
 - The value increases by 11% every 3 years.
 - The value decreases by 5% every 6 months.
57. A new home is purchased for \$150,000. The value of the home increases by 11% every 2 years. Write an exponential function for the value of the home using time in years as the input quantity.
58. A new home is purchased for \$200,000. The value of the home increases by 1.5% every 5 years. Write an exponential function for the value of the home using time in years as the input quantity.
59. A new home is purchased for \$195,000. The value of the home decreases by 4% every 3 years. Write an exponential function for the value of the home using time in years as the input quantity.
60. A new home is purchased for \$420,000. The value of the home decreases by 8% every 4 years. Write an exponential function for the value of the home using time in years as the input quantity.

Chapter 5: Savings

Chapter 5 Learning Objectives:

- Recognize that simple interest grows linearly
- Be able to correctly apply the simple interest formula to solve for A, r, t, or P_0
- Recognize that compound interest grows exponentially
- Correctly apply the compound interest formula to solve for A, r, or P_0
- Recognize that the compound interest formula is used for solving when you have a one-time, lump sum deposit
- Calculate the APY for an account earning compound interest

Section 5.1 – Simple Interest

Section 5.2 – Compound Interest

Section 5.3 – Annual Percentage Yield (APY)

Section 5.1 – Simple Interest

Discussing interest starts with the **principal**, or amount your account starts with initially. This could be a starting investment, or the starting amount of a loan. Interest, in its most simple form, is calculated as a percent of the principal.

APR – Annual Percentage Rate

Interest rates are usually given as an **annual percentage rate (APR)** – the total interest that will be paid in the year.

For most long term, simple interest loans, it is common for interest to be paid on an annual basis. In that case, interest would be earned each year on the principal.

For example, suppose you borrowed \$10,000 from a friend and agree to repay it with 3% annual interest, in 5 years. You would not only repay your friend the \$10,000 you borrowed. You would also pay simple interest for each year you had borrowed the money.

Year	Starting balance	Interest earned	Ending Balance
1	10,000.00	300.00	10,300.00
2	10,300.00	300.00	10,600.00
3	10,600.00	300.00	10,900.00
4	10,900.00	300.00	11,200.00
5	11,200.00	300.00	11,500.00

The total amount you would repay your friend would be \$11,500.00, which is the original principal plus the interest over 5 years.

This process can be generalized with the following formulas:

Simple Interest over Time
$I = P_0rt$ $A = P_0 + I = P_0 + P_0rt = P_0(1 + rt)$ <p>I is the dollar amount of interest A is the balance in the account after t years P_0 is the balance in the account at the beginning (starting amount, or principal). r is the annual interest rate (APR) in decimal form (Example: 5% = 0.05) t is the number of years we plan to leave the money in the account</p>

Bonds are essentially a loan made to the bond issuer (a company or government) by you, the bond holder. In return for the loan, the issuer agrees to pay interest, often annually. Bonds have a maturity date, at which time the issuer pays back the original bond value.

Example 1
<p>Suppose your city is building a new park, and issues bonds to raise the money to build it. You obtain a \$5,000 bond that pays 4.5% interest annually that matures in 5 years.</p> $A = 5000(1 + 0.045(5))$ $A = \$6125$ <p>When the bond matures, you would receive back the \$5,000 you originally paid, plus \$1125 in interest, leaving you with a total of \$6125.</p>

You Try 5.1
<p>Maria invests \$16,000 at 3% simple interest for 19 years.</p> <ul style="list-style-type: none"> • How much interest will she earn? • How much is in the account at the end of the 19 year period?

Section 5.2 – Compound Interest

With simple interest, we were assuming that we pocketed the interest when we received it. In a standard bank account, any interest we earn is automatically added to our balance, and we earn interest on that interest in future years. This reinvestment of interest is called **compounding**.

Suppose that we deposit \$1,000 in a bank account offering 3% interest, compounded monthly. How will our money grow?

The 3% interest is an annual percentage rate (APR) – the total interest to be paid during the year. Since our interest is being paid monthly, each month we will earn $\frac{1}{12}$ of the 3% annual interest, or $\frac{3\%}{12} = 0.25\%$ per month.

In the first month,

$$P_0 = \$1,000$$

$$r = 0.0025 \text{ (0.25\%)}$$

$$I = \$1,000 (0.0025) = \$2.50$$

$$A = \$1,000 + \$2.50 = \$1,002.50$$

In the first month, we will earn \$2.50 in interest, raising our account balance to \$1002.50.

In the second month,

$$P_0 = \$1,002.50$$

$$I = \$1,002.50 (0.0025) = \$2.51 \text{ (rounded)}$$

$$A = \$1,002.50 + \$2.51 = \$1,005.01$$

Notice that in the second month we earned more interest than we did in the first month. This is because we earned interest not only on the original \$1000 we deposited, but we also earned interest on the \$2.50 of interest we earned the first month. This is the key advantage that **compounding** of interest gives us.

Calculating out a few more months (rounding to the nearest cent):

Month	Starting balance	Interest earned	Ending Balance
1	1000.00	2.50	1002.50
2	1002.50	2.51	1005.01
3	1005.01	2.51	1007.52
4	1007.52	2.52	1010.04
5	1010.04	2.53	1012.57
6	1012.57	2.53	1015.10
7	1015.10	2.54	1017.64
8	1017.64	2.54	1020.18
9	1020.18	2.55	1022.73
10	1022.73	2.56	1025.29
11	1025.29	2.56	1027.85
12	1027.85	2.57	1030.42

The standard formula for compound interest is as follows:

Compound Interest:

$$A = P_0 \left(1 + \frac{r}{n} \right)^{nt}$$

A is the balance in the account after t years

t is the number of years we plan to leave the money in the account

P_0 is the balance in the account at the beginning (starting amount, or principal).

r is the annual interest rate (APR) in decimal form (Example: 5% = 0.05)

n is the number of compounding periods in one year.

If the compounding is done annually (once a year), $n = 1$.

If the compounding is done quarterly, $n = 4$.

If the compounding is done monthly, $n = 12$.

If the compounding is done daily, $n = 365$.

The most important thing to remember about using this formula is that it assumes that we put money in the account once and let it sit there earning interest.

Example 2

If you invest \$3,000 in an investment account paying 3% interest compounded quarterly, how much will the account be worth in 10 years?

Since we are starting with \$3,000, $P_0 = 3,000$

Our interest rate is 3%, so $r = 0.03$

Since we are compounding quarterly, we are compounding 4 times per year, so $n = 4$

We want to know the value of the account in 10 years, so we are looking for the ending value, A , when $t = 10$.

$$A = 3,000 \left(1 + \frac{0.03}{4} \right)^{4(10)} = \$4,045.05$$

The account will be worth \$4,045.05 in 10 years.

You Try 5.2

If you invest \$3,000 in an investment account paying 3% interest compounded *weekly*, how much will the account be worth in 10 years?

Example 3

A certificate of deposit (CD) is a savings instrument that many banks offer. It usually gives a higher interest rate, but you cannot access your investment for a specified length of time. Suppose you deposit \$3,000 in a CD paying 6% interest, compounded monthly. How much will you have in the account after 20 years?

In this example,

$P_0 = \$3,000$	the initial deposit
$r = 0.06$	6% annual rate
$n = 12$	12 months in 1 year
$t = 20$	since we're looking for how much we'll have after 20 years

$$\text{So } A = 3,000 \left(1 + \frac{0.06}{12} \right)^{12 \cdot 20} = \$9,930.61 \quad (\text{round your answer to the nearest penny})$$

Let us compare the amount of money earned from compounding against the amount you would earn from simple interest

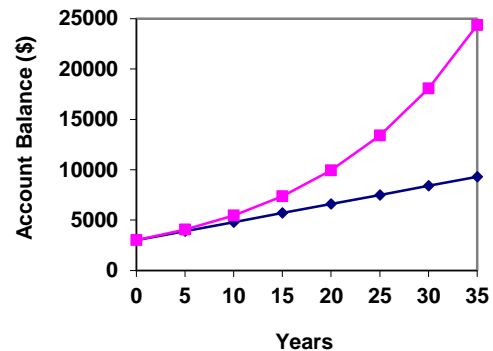

Years	Simple Interest (\$15 per month)	6% compounded monthly = 0.5% each month.
5	\$3900	\$4046.55
10	\$4800	\$5458.19
15	\$5700	\$7362.28
20	\$6600	\$9930.61
25	\$7500	\$13394.91
30	\$8400	\$18067.73
35	\$9300	\$24370.65

As you can see, over a long period of time, compounding makes a large difference in the account balance. You may recognize this as the difference between linear growth and exponential growth.

Example 4

A 529 plan is a college savings plan in which a relative can invest money to pay for a child's later college tuition, and the account grows tax free. If Lily wants to set up a 529 account for her new granddaughter, wants the account to grow to \$40,000 over 18 years, and she believes the account will earn 6% compounded semi-annually (twice a year), how much will Lily need to invest in the account now?

Since the account is earning 6%, $r = 0.06$

Since interest is compounded twice a year, $n = 2$

In this problem, we don't know how much we are starting with, so we will be solving for P_0 , the initial amount needed. We do know we want the end amount, A , to be \$40,000, so we will be looking for the value of P_0 so that $A = 40,000$.

$$40,000 = P_0 \left(1 + \frac{0.06}{2} \right)^{2(18)}$$

$$40,000 = P_0 (2.898278328)$$

$$P_0 = \frac{40,000}{2.898278328} \approx \$13,801.30$$

Lily will need to invest \$13,801.30 to have \$40,000 in 18 years.

A Note on Rounding

It is important to be very careful about rounding when performing calculations. If possible, enter the entire calculation in one step into your calculator to avoid rounding error. If this is not possible, you want to keep as many decimals during calculations as you can. Try calculating example 2 using 2.898 instead of 2.898278328, and compare your answer with the example.

You Try 5.2

If Lily wants to set up a 529 account for her new granddaughter, wants the account to grow to \$40,000 over 18 years, and she believes the account will earn 6% compounded *daily*, how much will Lily need to invest in the account now?

Section 5.3 – Annual Percentage Yield (APY)

Because of compounding throughout the year, with compound interest the actual increase in a year is usually *more* than the annual percentage rate. If \$1,000 were invested at 10%, the following table shows the value after 1 year at different compounding frequencies:

Frequency	Value after 1 year
Annually	\$1100
Semiannually	\$1102.50
Quarterly	\$1103.81
Monthly	\$1104.71
Daily	\$1105.16

If we were to compute the actual percentage increase for the daily compounding (last row of the table above), there was an increase of \$105.16 from an original amount of \$1,000, for a percentage increase of $\frac{105.16}{1000} = 0.10516 = 10.516\%$ increase. This quantity is called the **annual percentage yield (APY)**.

Notice that given any starting amount, the amount after 1 year would be

$A(1) = P_0 \left(1 + \frac{r}{n}\right)^n$. To find the total change, we would subtract the original amount, then to find the percentage change we would divide that by the original amount:

Annual Percentage Yield

The **annual percentage yield** is the actual percent a quantity increases in one year. It can be calculated as

$$APY = \frac{\text{Balance after one year} - \text{Starting Principal}}{\text{Starting Principal}} = \frac{P_0 \left(1 + \frac{r}{n}\right)^n - P_0}{P_0} = \left(1 + \frac{r}{n}\right)^n - 1$$

The above formula should look very similar to the one we used to find the Relative Change in Chapter 4.

Example 5

Bank A offers an account paying 1.2% compounded quarterly. Bank B offers an account paying 1.1% compounded monthly. Which is offering a better rate?

We can compare these rates using the annual percentage yield – the actual percent increase in a year.

$$\text{Bank A: } APY = \left(1 + \frac{0.012}{4}\right)^4 - 1 = 0.012054 = 1.2054\%$$

$$\text{Bank B: } APY = \left(1 + \frac{0.011}{12}\right)^{12} - 1 = 0.011056 = 1.1056\%$$

Bank B's monthly compounding is not enough to catch up with Bank A's better APR. Bank A offers a better rate.

You Try 5.3

- | |
|--|
| <p>a. Calculate the APY for an account that pays 4% compounded daily.</p> <p>b. Calculate the APY for an account that pays 4% compounded monthly.</p> <p>c. Calculate the APY for an account that pays 4% compounded annually.</p> |
|--|

The table below shows the APY for \$1000 invested in an account that pays 10% at different compounding frequencies:

Frequency	Value after 1 year	APY
Annually	\$1100	10%
Semiannually	\$1102.50	10.25%
Quarterly	\$1103.81	10.381%
Monthly	\$1104.71	10.471%
Daily	\$1105.16	10.516%

Notice that the APY is always greater than the APR if interest is compounded more than once a year.

Chapter 5 – Answers to You Try Problems

- 5.1. At the end of the 19 year period, she will have earned \$9120 in interest. The balance in her account will be \$25120.
- 5.2 Lily will need to invest \$13,693.20 to have \$40,000 in 18 years.
- 5.3
- a. 4% compounded daily: $APY = 4.081\%$
 - b. 4% compounded monthly: $APY = 4.074\%$
 - c. 4% compounded annually: $APY = 4\%$

Chapter 5 – Practice Problems

When needed, round your answer to the nearest cent.

1. Janelle invests \$18,000 at 8% simple interest for 41 years. How much is in the account at the end of the 41-year period?
2. Carlos invests \$15,000 at 2% simple interest for 29 years. How much is in the account at the end of the 29-year period?
3. Kristina invests \$13,000 at 7% simple interest for 32 years. How much is in the account at the end of the 32-year period?
4. How much would you need to deposit in an account now in order to have \$3,000 in the account in 5 years? Assume the account earns 2% simple interest.
5. How much would you need to deposit in an account now in order to have \$2,000 in the account in 15 years? Assume the account earns 6% simple interest.
6. You invest \$9600 in a savings account that pays 3.6% simple interest. How long will it take for this investment to double in value? Round your answer to the nearest cent.
7. Jenelle wants to invest \$500 in a savings account that pays 4.3% simple interest. How long will it take for this investment to triple in value? Round your answer to the nearest cent.
8. Brian invests \$1200 in a savings account that pays 5.1% simple interest. How long will it take for this investment to double in value? Round your answer to the nearest cent.
9. You deposit \$300 in an account earning 5% interest compounded annually. How much will you have in the account in 10 years?
10. How much will \$1,000 deposited in an account earning 7% interest compounded annually be worth in 20 years?
11. You deposit \$9,400 in an account earning 4% interest compounded semi-annually. How much will you have in the account in 5 years?
12. You deposit \$2,100 in an account earning 2.5% interest compounded semi-annually. How much will you have in the account in 7 years?
13. You deposit \$4,000 in an account earning 8% interest compounded monthly. How much will you have in the account in 10 years?

14. You deposit \$200 in an account earning 5.2% interest compounded monthly. How much will you have in the account in 15 years?
15. You deposit \$2,000 in an account earning 3% interest compounded monthly.
 - a. How much money will you have in the account in 20 years?
 - b. How much interest will you earn?
16. You deposit \$10,000 in an account earning 4% interest compounded monthly.
 - a. How much money will you have in the account in 25 years?
 - b. How much interest will you earn?
17. You deposit \$5,300 in an account earning 5% interest compounded quarterly. How much will you have in the account in 6 years?
18. You deposit \$7,000 in an account earning 3.5% interest compounded quarterly. How much will you have in the account in 8 years?
19. You deposit \$3,000 in an account earning 8% interest compounded quarterly. How much will you have in the account in 10 years?
20. How much would you need to deposit in an account now in order to have \$4,000 in the account in 10 years? Assume the account earns 3% interest compounded monthly.
21. How much would you need to deposit in an account now in order to have \$2,500 in the account in 5 years? Assume the account earns 2.5% interest compounded monthly.
22. How much would you need to deposit in an account now in order to have \$6,000 in the account in 8 years? Assume the account earns 6% interest compounded monthly.
23. How much would you need to deposit in an account now in order to have \$20,000 in the account in 10 years? Assume the account earns 7% interest compounded quarterly.
24. How much would you need to deposit in an account now in order to have \$3,000 in the account in 15 years? Assume the account earns 2% interest compounded quarterly.
25. How much would you need to deposit in an account now in order to have \$7,000 in the account in 10 years? Assume the account earns 3% interest compounded annually.

26. You deposit \$23,000 in an account. Find the value of the investment at the end of 10 years if the account earns
 - a. 7% interest compounded annually
 - b. 7% simple interest

27. You deposit \$4,000 in an account. Find the value of the investment at the end of 10 years if the account earns
 - a. 5% interest compounded annually
 - b. 5% simple interest

28. A bank features a savings account that has an annual percentage rate of 2.8% with interest compounded monthly. Devin deposits \$9,500 into the account.
 - a. How much money will Devin have in the account in 1 year?
 - b. What is the annual percentage yield (APY) for the savings account?

29. A bank features a savings account that has an annual percentage rate of 5.1% with interest compounded quarterly. Miranda deposits \$3,000 into the account.
 - a. How much money will Miranda have in the account in 1 year?
 - b. What is the annual percentage yield (APY) for the savings account?

30. Calculate the APY for an account that pays 3.6% compounded monthly.

31. Calculate the APY for an account that pays 5.8% compounded semi-annually.

32. Calculate the APY for an account that pays 4.7% compounded quarterly.

33. Calculate the APY for an account that pays 2.3% compounded quarterly.

34. Calculate the APY for an account that pays 5.9% compounded annually.

35. Calculate the APY for an account that pays 6%
 - a. compounded daily
 - b. compounded monthly
 - c. compounded annually

36. Calculate the APY for an account that pays 15%
 - a. compounded daily
 - b. compounded monthly
 - c. compounded annually

Chapter 6 – Annuities and Loans

Chapter 6 Learning Objectives:

- Recognize that an annuity involves equal, regular payments or deposits
- Be able to correctly apply the savings annuity formula and solve for any unknown using the TVM solver
- Be able to correctly apply the payout annuity formula and solve for any unknown using the TVM solver
- Be able to correctly apply the loan formula for amortized loans and solve for any unknown using the TVM solver
- Solve real world problems that involve both planning for retirement and withdrawing from retirement accounts
- Recognize how the proportions of a payment going toward principal and interest change over the life of a loan

Section 6.1 – Annuities

Section 6.2 – Payout Annuities

Section 6.3 – Loans

Section 6.1 – Annuities

Most of us aren't able to put a large sum of money in the bank today. Instead, we save by depositing a smaller amount of money from each paycheck into the bank. This idea is called a **savings annuity**. This is how most retirement accounts work.

In this course, we will assume that you put equal amounts of money into the account on a regular schedule (every month, year, quarter, etc.) and let it sit there earning interest.

Suppose you start out by making monthly deposits of \$100 into an account that earns 12% annual interest. We assume that the account is compounded with the same frequency as we make deposits unless stated otherwise. If payments are made monthly, we assume interest is compounded monthly. If payments are made annually, we assume interest is compounded annually. We will also assume in this course that all compounding and payments occur at the END of the month.

In this example with monthly payments, we assume the 12% is compounded monthly (or 1% each month). So, you make your first \$100 deposit at the end of the first month. At the end of the second month, you make another \$100 deposit PLUS you earn 1% interest on the prior balance (in this case 1% of \$100 = \$1) making the balance in your account \$201 at the end of month 2.

In general,

Ending Balance = Prior Balance + 1% Interest on Prior Balance + Monthly Payment

The table below shows this process repeated for 6 months.

Month	Prior Balance	1% Interest on Prior Balance	Monthly Payment	Ending Balance
1	\$0	\$0	\$100	\$100
2	\$100	\$1	\$100	\$201
3	\$201	\$2.01	\$100	\$303.01
4	\$303.01	\$3.03	\$100	\$406.04
5	\$406.04	\$4.06	\$100	\$510.10
6	\$510.10	\$5.10	\$100	\$615.20

This process can be generalized by the Annuity Formula.

Annuity Formula
$A = \frac{PMT \left(\left(1 + \frac{r}{n} \right)^{nt} - 1 \right)}{\left(\frac{r}{n} \right)}$
<p>A is the balance in the account after t years. PMT is the regular deposit (the amount you deposit each year, each month, etc.) r is the annual interest rate (APR) in decimal form (Example: 5% = 0.05) n is the number of compounding periods in one year t is the number of years we plan to make monthly deposits</p>

If the compounding frequency is not explicitly stated, assume there are the same number of compounds in a year as there are deposits made in a year. For example, if the compounding frequency isn't stated:

If you make your deposits every month, use monthly compounding, $n = 12$.

If you make your deposits every year, use yearly compounding, $n = 1$.

If you make your deposits every quarter, use quarterly compounding, $n = 4$.

Etc...

When do you use the Annuity formula?
<p>Annuities assume that you put money in the account <u>on a regular schedule (every month, year, quarter, etc.)</u> and let it sit there earning interest.</p>
<p>Compound interest assumes that you put money in the account <u>once</u> and let it sit there earning interest.</p>
<p>Compound interest: <u>One</u> deposit Annuity: <u>Many</u> deposits.</p>

Example 1

A traditional individual retirement account (IRA) is a special type of retirement account in which the money you invest is exempt from income taxes until you withdraw it. If Charlotte deposits \$100 each month into an IRA earning 6% interest, how much will she have in the account after 20 years?

In this example,

$PMT = \$100$	the monthly deposit
$r = 0.06$	6% annual rate
$n = 12$	since we're doing monthly deposits, we'll compound monthly
$t = 20$	we want the amount after 20 years

Putting this into the equation:

$$A = \frac{100 \left(\left(1 + \frac{0.06}{12} \right)^{12 \cdot 20} - 1 \right)}{\left(\frac{0.06}{12} \right)}$$

$$A = \frac{100 \left((1.005)^{240} - 1 \right)}{(0.005)}$$

$$A = \frac{100(3.310 - 1)}{0.005}$$

$$A = \frac{100(2.310)}{0.005} = \$46,204.09$$

Charlotte's account will grow to \$46,204.09 after 20 years.

Notice that she deposited into the account a total of \$24,000 (\$100 a month for 240 months). The difference between what she ends up with and how much she put in is the interest earned. In this case it is $\$46,204.09 - \$24,000 = \$22,204.09$.

In the example above, each step was shown individually to demonstrate how to work your way through this formula when doing the steps by hand. The TVM Solver program on your graphing calculator can perform this calculation for you, and do it much quicker! The following guide will introduce you to the TVM solver.

Using the TVM Solver on your graphing calculator

Press **APPS**, then **Finance**, and **TVM Solver** (Note: If you have an older TI-83 calculator and do not have an APPS key, look for a key labeled Finance.)

You will see a screen like the following: (Note: You will see different numbers after each parameter. There's no reason to reset to zero--you will type right over them.)

```

N=240
I%=5
PV=0
PMT=243.28907...
FV=100000
P/Y=12
C/Y=12
PMT:END BEGIN
  
```

N **Total number of payment/compounding periods** (this is nt where n is the number of compoundings per year and t is the time in years)

I% **Annual interest rate (APR)** (Entered as a percent, NOT as a decimal.)

PV **Present Value** (the principal or beginning amount)

PMT **Payment Amount** (must be equal regular payments)

FV **Future Value** (accumulated value or end amount)

P/Y Number of payment periods per year

C/Y Number of compounding periods per year

PMT: For this class, keep the setting on END, indicating end-of-the month payments.

For our applications, C/Y will always be the same value as P/Y. If you change P/Y, your calculator will automatically reset C/Y.

NOTES:

- Cash outflows are considered negative.
- Cash inflows are considered positive.
- Deposits and loan payments are negative because they represent an amount you must pay *out* every month.

TVM Solver will calculate the value of ANY of the first five values in the above list (N, I%, PV, PMT or FV) if the other four values are known. To solve for an unknown value, you will put the cursor on the line you wish to find and then press SOLVE (press ALPHA, then the ENTER key).

Example 2 – Repeat Example 1 TVM Solver

A traditional individual retirement account (IRA) is a special type of retirement account in which the money you invest is exempt from income taxes until you withdraw it. If you deposit \$100 each month into an IRA earning 6% interest. How much will you have in the account after 20 years?

We are looking for the future value (FV) of this account after 20 years. In this example,

$$N = 20 \cdot 12$$

$$I\% = 6$$

PV = 0 (There is no initial lump sum deposit)

$$PMT = -100$$

FV = This is what you are solving for.

$$P/Y = 12$$

$$C/Y = 12$$

PMT: END

Once all of the given parameters are entered in, move your cursor to FV= and press ALPHA – ENTER.

FV = 46,204.08952 so the future value (ending balance) will be \$46,204.09.

Example 3

You want to have \$200,000 in your account when you retire in 30 years. Your retirement account earns 8% interest. How much do you need to deposit each month to meet your retirement goal?

In this example, we're looking for *PMT*.

$$r = 0.08 \quad \text{8\% annual rate}$$

$$n = 12 \quad \text{since we're depositing monthly}$$

$$t = 30 \quad \text{30 years}$$

$$A = \$200,000 \quad \text{The amount we want to have in 30 years}$$

By hand, we could set up the equation, and solve for *d*:

$$200,000 = \frac{PMT \left(\left(1 + \frac{0.08}{12} \right)^{12 \cdot 30} - 1 \right)}{\left(\frac{0.08}{12} \right)}$$

$$PMT = \$134.20$$

Using the TVM Solver: We are looking for the monthly deposit required (PMT) to have a future value of \$200,000 in the account after 30 years, with an annual interest rate of 8%. In this example,

$$N = 30 * 12$$

$$I\% = 8$$

$$PV = 0 \quad (\text{There is no initial lump sum deposit})$$

PMT = This is what you are solving for.

$$FV = 200000$$

$$P/Y = 12$$

$$C/Y = 12$$

PMT: END

Once all of the given parameters are entered in, move your cursor to PMT = and press ALPHA – ENTER.

$$PMT = -134.20.$$

So you would need to deposit \$134.20 each month to have \$200,000 in 30 years if your account earns 8% interest.

You Try 6.1A

A more conservative investment account pays 3% interest. If you deposit \$5 a day into this account, how much will you have after 10 years? How much is from interest?

Example 4

You want to have \$200,000 in your account when you retire in 30 years. Your retirement account earns 8.2% interest. How much do you need to deposit each month to meet your retirement goal?

In this example,

$$N = 30 * 12$$

$$I\% = 8.2$$

$$PV = 0$$

PMT = This is what you are solving for.

$$FV = 200,000$$

$$P/Y = 12$$

$$C/Y = 12$$

PMT: END

Once all of the given parameters are entered in, move your cursor to PMT= and press ALPHA – ENTER.

PMT = -128.84224 so you will need to deposit \$128.85 each month to reach the goal.

You Try 6.1B

If you want to end up with \$30,000 after 5 years in an account earning 5.2% interest, compounded monthly, how much is your monthly deposit?

Example 5

Emily invests \$250 a month for 5 years into an account earning 4% interest compounded monthly. After 5 years, she leaves the money, without making additional deposits, in the account for another 25 years. How much will Emily have in the end?

This problem requires two steps.

Step 1: Initially, monthly deposits are being made into a saving annuity for a period of 5 years. This is new for section 6.1.

Step 2: After that, the amount that has accrued from step 1 will sit (as a lump sum) and continue to earn compound interest for 25 more years. This is regular compound interest from section 5.2.

Step 1: Find the amount in the account after monthly payments are made for 5 years.

$$N = 12 * 5$$

$$I\% = 4$$

$$PV = 0$$

$$PMT = -250$$

FV = This is what you are solving for

$$P/Y = 12$$

$$C/Y = 12$$

PMT: END

Once all of the given parameters are entered in, move your cursor to FV= and press ALPHA – ENTER.

FV = \$16,574.74. After 5 years of making monthly payments, Emily will have \$16,574.74 in the account.

Step 2: Find the amount in the account after 25 years.

Recall, the compound interest formula is: $A = P_o \left(1 + \frac{r}{n}\right)^{nt}$

$$A = 16,574.74 \left(1 + \frac{0.04}{12}\right)^{12 * 25}$$

$A = \$44,979.95$ The final amount Emily will have in the account is \$44,979.95

Section 6.2 – Payout Annuities

In the last section you learned about annuities. In an annuity, you start with nothing, put money into an account on a regular basis, and end up with money in your account. In this section, we will learn about a variation called a **Payout Annuity**. With a payout annuity, you start with money in the account, and pull money out of the account on a regular basis. Any remaining money in the account earns interest. After a fixed amount of time, the account will end up empty. Payout annuities are typically used after retirement. Perhaps you have saved \$500,000 for retirement, and want to take money out of the account each month to live on. You want the money to last you 20 years. This is a payout annuity.

Payout Annuity Formula

$$P_0 = \frac{PMT \left(1 - \left(1 + \frac{r}{n} \right)^{-nt} \right)}{\left(\frac{r}{n} \right)}$$

P_0 is the balance in the account at the beginning (starting amount, or principal).

PMT is the regular withdrawal (the amount you take out each year, each month, etc.)

r is the annual interest rate (APR) in decimal form (Example: 5% = 0.05)

n is the number of compounding periods in one year.

t is the number of years we plan to take withdrawals

Like with annuities, the compounding frequency is not always explicitly given, but is determined by how often you take the withdrawals.

When do you use the Payout Annuity Formula?

Payout annuities assume that you take money from the account on a regular schedule (every month, year, quarter, etc.) and let the rest sit there earning interest.

Compound interest: One deposit

Annuity: Many deposits.

Payout Annuity: Many withdrawals

Example 6

After retiring, you want to be able to take \$1,000 every month for a total of 20 years from your retirement account. The account earns 6% interest. How much will you need in your account when you retire?

Putting this into the equation:
$$P_0 = \frac{1,000 \left(1 - \left(1 + \frac{0.06}{12} \right)^{-12 \cdot 20} \right)}{\left(\frac{0.06}{12} \right)} = \$139,580.77$$

Using TVM Solver:

$$N = 12 \cdot 20$$

$$I\% = 6$$

PV = This is what you are solving for.

$$PMT = 1000$$

$$FV = 0$$

$$P/Y = 12$$

$$C/Y = 12$$

PMT: END

Once all of the given parameters are entered in, solve for PV. $PV = -139,580.7717$

You will need \$139,580.78 in the account by the time you retire

Example 7

You know you will have \$500,000 in your account when you retire. You want to be able to take annual withdrawals from the account for a total of 30 years. Your retirement account earns 8% interest. How much will you be able to withdraw each year?

Putting this into the equation:
$$500,000 = \frac{PMT \left(1 - \left(1 + \frac{0.08}{1} \right)^{-1 \cdot 30} \right)}{\left(\frac{0.08}{1} \right)}$$

Solve for PMT to get $PMT = 44,413.71669$

Using TVM Solver:

$$N = 1 \cdot 30$$

$$I\% = 8$$

$$PV = -500000$$

PMT = This is what you are solving for.

$$FV = 0$$

$$P/Y = 1$$

$$C/Y = 1$$

PMT: END

Once all of the given parameters are entered in, solve for PMT.

$$PMT = 44,413.71669$$

So you would be able to withdraw \$44,413.72 each year for 30 years.

You Try 6.2

After retiring, you want to be able to take \$50,000 every year for a total of 25 years from your retirement account. The account earns 7% interest. How much will you need in your account when you retire?

Example 8

You want to be able to withdraw \$65,000 from your account each year for 30 years after you retire. You expect to retire in 25 years. If your account earns 6% interest, how much will you need to deposit each year until retirement to achieve your retirement goals?

This problem requires two steps.

Step 1: Initially, figure out how much money you need to have in your account at retirement so that you can withdraw \$65,000 per year for 30 years.

Step 2: After that, figure out how much money you need to deposit every year before retirement, so that you have the amount needed from Step 1 after 25 years.

Step 1: Find the amount you need to have in your account at retirement so that you can make annual withdrawals of \$65,000 per year for 30 years.

$$N = 1 * 30$$

$$I\% = 6$$

PV = This is what you are solving for.

$$PMT = -65,000$$

$$FV = 0$$

$$P/Y = 1$$

$$C/Y = 1$$

PMT: END

Once all of the given parameters are entered in, move your cursor to PV= and press ALPHA – ENTER.

PV = \$894,714.02. You need to have \$894,714.02 in your retirement account so that you can withdraw \$65,000 per year for 30 years.

Step 2: Find the amount you need to deposit each year in order to have \$894,714.02 in 25 years.

$$N = 1 * 25$$

$$I\% = 6$$

$$PV = 0$$

PMT = This is what you are solving for.

$$FV = 894,714.02$$

$$P/Y = 1$$

$$C/Y = 1$$

PMT: END

Once all of the given parameters are entered in, move your cursor to PMT= and press ALPHA – ENTER.

$$PMT = -\$16,307.70.$$

You need to deposit \$16,307.70 each year for 25 years, so that you will have enough money in your account when you retire to withdraw \$65,000 per year for 30 years.

Section 6.3 – Loans

In the last section, you learned about payout annuities.

In this section, you will learn about conventional loans (also called amortized loans or installment loans). Examples include auto loans and home mortgages. These techniques do not apply to payday loans, add-on loans, or other loan types where the interest is calculated up front.

One great thing about loans is that they use exactly the same formula as a payout annuity. To see why, imagine that you had \$10,000 invested at a bank, and started taking out payments while earning interest as part of a payout annuity, and after 5 years your balance was zero. Flip that around, and imagine that you are acting as the bank, and a car lender is acting as you. The car lender invests \$10,000 in you. Since you're acting as the bank, you pay interest. The car lender takes payments until the balance is zero.

Suppose you borrow \$1,000 at a 12% annual interest rate. Again, we assume that the account is compounded with the same frequency as we make payments unless stated otherwise.

In this example with monthly payments, we assume the 12% is compounded monthly (or 1% each month). So, you make your first \$100 payment at the end of the first month. At the end of the second month, you make another \$100 payment, but you also have to add 1% interest on the prior balance (in this case 1% of \$1,000 = \$10) making the new balance (amount owed) \$910 at the end of month 2.

In general,

$$\text{Ending Balance} = \text{Prior Balance} + 1\% \text{ Interest on Prior Balance} - \text{Monthly Payment}$$

The table below shows this process over 4 months.

Month	Prior Balance	1% Interest on Prior Balance	Monthly Payment	Ending Balance
1				\$1,000
2	\$1,000	\$10	\$100	\$910
3	\$910	\$9.10	\$100	\$819.10
4	\$819.10	\$8.19	\$100	\$727.29
And so on

Notice that each month, the interest that must be paid decreases slightly (because you have made a payment that has decreased the principal). In an installment loan, the monthly payments are a fixed amount, so early on in the loan a larger proportion of your payment is being applied to interest, and a smaller proportion of your payment is being applied toward paying down the principal. As the term of the loan proceeds, the proportion of the payment going toward interest gradually decreases, and the proportion of the payment going toward principal gradually increases.

As an example, the graph below shows the relationship between the amount of the payment going towards principal, and the amount of the payment going towards interest for a 30 year mortgage.

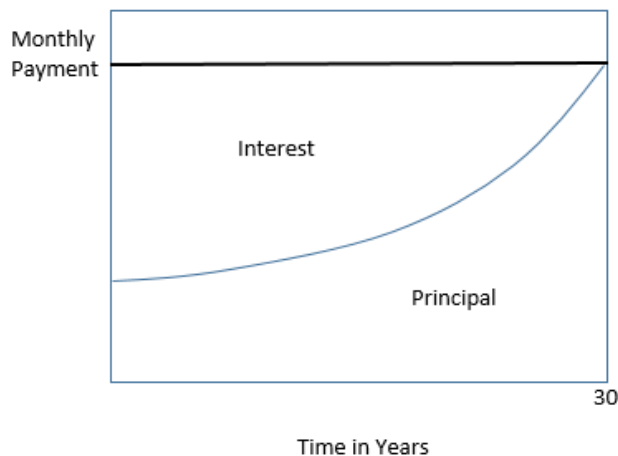

Example 9

You take out a 5 year installment loan to purchase a new vehicle. Your monthly payment is fixed at \$485.22 for those 5 years, after which you will have paid off the loan in full. Will a larger proportion of your payment go towards principal during year 1 of the loan, or year 4 of the loan?

You owe the most money on your car when you first buy it. Since the interest due is calculated based on how much you currently owe on the loan, you owe the most interest during the first month. Keep in mind that your payment is a fixed amount, \$485.22. Early in the loan, a larger proportion of your payment is going towards paying interest, while a smaller proportion of your payment is being applied to principal. As you gradually decrease your principal (the amount you owe), your interest due each month decreases as well. This means that over the life of the loan, a larger proportion of your payment can be used to pay down the principal.

During year 4 of the loan, a larger proportion of the fixed payment will go towards principal than during year 1 of the loan.

The following formula generalizes the installment loan process:

Loan Formula

$$P_0 = \frac{PMT \left(1 - \left(1 + \frac{r}{n} \right)^{-nt} \right)}{\left(\frac{r}{n} \right)}$$

P_0 is the balance in the account at the beginning (starting amount, or principal).

PMT is your loan payment (your monthly payment, annual payment, etc)

r is the annual interest rate (APR) in decimal form (Example 5% = 0.05)

n is the number of compounding periods in one year.

t is the number of years we plan to borrow the money (length of the loan, in years)

Like before, the compounding frequency is not always explicitly given, but is determined by how often you make payments.

When do you use the Loan Formula?

The loan formula assumes that you make loan payments on a regular schedule (every month, year, quarter, etc.) and are paying interest on the loan.

Compound interest: One deposit

Annuity: Many deposits.

Payout Annuity: Many withdrawals

Loans: Many payments

Example 10

Abigale can afford \$200 per month as a car payment. If she can get an auto loan at 3% interest for 60 months (5 years), how expensive of a car can she afford (in other words, what amount loan can Abigale pay off with \$200 per month)?

In this example, we are looking for P_0 , the starting amount of the loan.

Putting this into the equation:
$$P_0 = \frac{200 \left(1 - \left(1 + \frac{0.03}{12} \right)^{-5(12)} \right)}{\left(\frac{0.03}{12} \right)} = \$11,130.47$$

So Abigale can afford a \$11,130.47 loan. She will pay a total of \$12,000 (\$200 per month for 60 months) to the loan company. The difference between the amount she pays and the amount of the loan is the interest paid.

In this case, Abigale is paying $\$12,000 - \$11,130.47 = \$869.53$ interest total.

You can also use TVM Solver to do this calculation.

Example 10b – Repeat Previous Example Using TVM Solver

Abigale can afford \$200 per month as a car payment. If she can get an auto loan at 3% interest for 60 months (5 years), how expensive of a car can she afford (in other words, what amount loan can she pay off with \$200 per month)?

In this example, we are looking for PV , the starting amount of the loan.

Using TVM Solver:

$$N = 12 * 5$$

$$I\% = 3$$

$PV =$ This is what you are solving for.

$$PMT = -200$$

$$FV = 0$$

$$P/Y = 12$$

$$C/Y = 12$$

PMT: END

Once all of the given parameters are entered in, solve for $PV =$ to get $PV = 11,130.47153$

So Abigale can afford a car loan of up to \$11,130.47.

Example 11

You want to take out a \$140,000 mortgage (home loan). The interest rate on the loan is 6%, and the loan is for 30 years. How much will your monthly payments be?

Using TVM Solver:

$$N = 12 * 30$$

$$I\% = 6$$

$$PV = 140,000$$

PMT = This is what you are solving for.

$$FV = 0$$

$$P/Y = 12$$

$$C/Y = 12$$

PMT: END

Once all of the given parameters are entered in, solve for PMT=

$$PMT = -839.37073$$

So you will make payments of \$839.38 per month for 30 years.

You're paying a total of \$302,176.80 to the loan company (\$839.38 per month for 360 months). You are paying a total of \$302,176.80 - \$140,000 = \$162,176.80 in interest over the life of the loan.

You Try 6.3A

Janine bought \$3,000 of new furniture on credit. Because her credit score isn't very good, the store is charging her a fairly high interest rate on the loan: 16%. If she agreed to pay off the furniture over 2 years, how much will she have to pay each month?

With loans, it is often desirable to determine what the **remaining loan balance** will be after some number of years. For example, if you purchase a home and plan to sell it in five years, you might want to know how much of the loan balance you will have paid off and how much you have to pay from the sale.

Remember that only a portion of your loan payments go towards the loan balance; a portion is going to go towards interest. For example, if your payments were \$1,000 a month, after a year you will *not* have paid off \$12,000 of the loan balance.

Example 12 (Continued from Example 11)

You want to take out a \$140,000 mortgage (home loan). The interest rate on the loan is 6%, and the loan is for 30 years. Your monthly payments are \$839.38. How much will still be owed after making payments for 10 years?

Using TVM Solver:

$$N = 12 \cdot 10$$

$$I\% = 6$$

$$PV = 140,000$$

$$PMT = -839.38$$

FV = This is what you are solving for.

$$P/Y = 12$$

$$C/Y = 12$$

PMT: END

Once all of the given parameters are entered in, solve for FV.

$$FV = -117,158.50$$

So you will still owe \$117,158.50 after making payments for 10 years.

You Try 6.3B

You finance a \$30,000 car at 2.9% interest for 60 months (5 years). What will your monthly payments be? How much will you still owe on the car after making payments for 2 years?

NOTE: Be sure to round the monthly payment UP to the nearest cent. Then use this (rounded) value when calculating the amount still owed. Round the amount owed UP to the nearest cent.

Chapter 6 – Answers to You-Try Problems

6.1A After 10 years, you will have \$21,282.07 in the account. \$3,032.07 is from interest.

6.1B Your monthly deposit should be \$438.89.

6.2 You will need \$582,679.16 in your account when you retire.

6.3A She will have to pay \$146.89 each month.

6.3B Monthly payments: \$537.73 per month
You will still owe \$18,518.61 after 2 years.

Chapter 6 – Practice Problems

When needed, round your answer to the nearest cent.

1. You deposit \$1,000 each year into an account earning 4% interest compounded annually. How much will you have in the account in 25 years?
2. You deposit \$3,000 each year into an account earning 7% interest compounded annually. How much will you have in the account in 15 years?
3. You deposit \$1,000 each year into an account earning 8% compounded annually.
 - a. How much will you have in the account in 10 years?
 - b. How much total money will you put into the account?
 - c. How much total interest will you earn?
4. You deposit \$100 each month into an account earning 6% interest compounded monthly.
 - a. How much will you have in the account in 15 years?
 - b. How much total money will you put into the account?
 - c. How much total interest will you earn?
5. You deposit \$200 each month into an account earning 3% interest compounded monthly.
 - a. How much will you have in the account in 30 years?
 - b. How much total money will you put into the account?
 - c. How much total interest will you earn?
6. Suppose you want to have \$500,000 for retirement in 20 years. Your account earns 10% interest.
 - a. How much would you need to deposit in the account each month?
 - b. How much total money will you put into the account?
 - c. How much interest will you earn?
7. Jose has determined he needs to have \$800,000 for retirement in 30 years. His account earns 6% interest.
 - a. How much would you need to deposit in the account each month?
 - b. How much total money will you put into the account?
 - c. How much total interest will you earn?
8. You wish to have \$3,000 in 2 years to buy a new stereo system. How much should you deposit each quarter into an account paying 8% compounded quarterly?
9. After retiring, you want to be able to withdraw \$1,500 each month for 25 years. Your account earns 6% interest. How much do you need in your account when you retire?

10. After retiring, you want to be able to withdraw \$20,000 each year for 15 years. Your account earns 7% interest. How much do you need in your account when you retire?
11. How much money will you need to have at retirement so you can withdraw \$60,000 a year for 20 years from an account earning 8% compounded annually?
12. You want to be able to withdraw \$30,000 each year for 25 years. Your account earns 8% interest.
 - a. How much do you need in your account at the beginning?
 - b. How much total money will you pull out of the account?
 - c. How much of that money is interest?
13. You want to be able to withdraw \$35,000 each year for 20 years. Your account earns 6% interest.
 - a. How much do you need in your account at the beginning?
 - b. How much total money will you pull out of the account?
 - c. How much of that money is interest?
14. You have \$500,000 saved for retirement. Your account earns 6% interest. How much will you be able to pull out each month, if you want to be able to take withdrawals for 20 years?
15. You have \$400,000 saved for retirement. Your account earns 7% interest. How much will you be able to pull out each month, if you want to be able to take withdrawals for 25 years?
16. You have \$300,000 saved for retirement. Your account earns 9% interest. How much will you be able to pull out each month, if you want to be able to take withdrawals for 15 years?
17. You can afford a \$700 per month mortgage payment. You can get a loan at 5% interest for 30 years.
 - a. What is the largest loan you can afford?
 - b. How much total money will you pay the loan company?
 - c. How much of that money is interest?
18. Marie can afford a \$250 per month car payment. She can get a loan at 7% interest for 5 years.
 - a. How expensive of a car can she afford?
 - b. How much total money will she pay the loan company?
 - c. How much of that money is interest?

19. You can afford a \$1,500 per month mortgage payment. You can get a loan at 8% interest for 25 years.
 - a. How big of a loan can you afford?
 - b. How much total money will you pay the loan company?
 - c. How much of that money is interest?

20. You can afford an \$850 per month mortgage payment. You can get a loan at 6% interest for 30 years.
 - a. What is the largest loan you afford?
 - b. How much total money will you pay the loan company?
 - c. How much of that money is interest?

21. You want to buy a \$28,000 car. You can make a 10% down payment, and will finance the balance with a 2% interest rate for 48 months (4 years). What will your monthly payments be?

22. You want to buy a \$32,000 car. You can make a 10% down payment, and will finance the balance with a 5% interest rate for 36 months (3 years). What will your monthly payments be?

23. You want to buy a \$200,000 home. You plan to pay 10% as a down payment, and take out a 30-year loan for the rest.
 - a. How much is the loan amount going to be?
 - b. What will your monthly payments be if the interest rate is 5%?
 - c. What will your monthly payments be if the interest rate is 6%?

24. Lynn bought a \$300,000 house, paying 10% down, and financing the rest at 6% interest for 30 years.
 - a. Find her monthly payments.
 - b. How much interest will she pay over the life of the loan?

25. You want to buy a \$25,000 car. The company is offering a 2% interest rate for 48 months (4 years). What will your monthly payments be?

26. You want to buy a \$33,000 car. The company is offering a 4% interest rate for 36 months (3 years). What will your monthly payments be?

27. You want to buy a \$16,000 car. The company is offering a 3% interest rate for 48 months (4 years). What will your monthly payments be?

28. You decide finance a \$12,000 car at 3% compounded monthly for 4 years.
 - a. What will your monthly payments be?
 - b. How much interest will you pay over the life of the loan?

29. Emily bought a car for \$24,000 three years ago. The loan had a 5-year term at 3% interest rate. How much does she still owe on the car?

30. A friend bought a house 15 years ago, taking out a \$120,000 mortgage at 6% for 30 years. How much does she still owe on the mortgage?
31. Suppose you invest \$140 a month for 6 years into an account earning 7% compounded monthly. After 6 years, you leave the money, without making additional deposits, in the account for another 26 years. How much will you have in the end?
32. Suppose you invest \$170 a month for 5 years into an account earning 6% compounded monthly. After 5 years, you leave the money, without making additional deposits, in the account for another 29 years. How much will you have in the end?
33. Lucy invests \$130 a month for 7 years into an account earning 9% compounded monthly. After 7 years, she leaves the money, without making additional deposits, in the account for another 23 years.
Alternatively, Monica didn't invest anything for the first 7 years, then deposited \$130 a month for 23 years into an account earning 9% compounded monthly.
- How much total money will Lucy have in the end?
 - How much total money will Monica have in the end?
 - How much of the total amount in Lucy's account is interest?
 - How much of the total amount in Monica's account is interest?
 - Which account had more total amount of money? Which account made more interest? Based on these observations, who made the better investment?
34. Robert invests \$180 a month for 6 years into an account earning 10% compounded monthly. After 6 years, you leave the money, without making additional deposits, in the account for another 20 years.
Alternatively, Nick didn't invest anything for the first 6 years, then deposited \$180 a month for 20 years into an account earning 10% compounded monthly.
- How much total money will Robert have in the end?
 - How much total money will Nick have in the end?
 - How much of the total amount in Robert's account is interest?
 - How much of the total amount in Nick's account is interest?
 - Which account had more total amount of money? Which account made more interest? Based on these observations, who made the better investment?
35. You want to be able to withdraw \$50,000 from your account each year for 30 years after you retire. You expect to retire in 25 years. If your account earns 9% interest, how much will you need to deposit each year until retirement to achieve your retirement goals?

36. You want to be able to withdraw \$25,000 from your account each year for 20 years after you retire. You expect to retire in 30 years. If your account earns 10% interest, how much will you need to deposit each year until retirement to achieve your retirement goals?

37. Mike wants to be able to withdraw \$10,000 from his retirement account every quarter for 10 years. He expects to retire in 15 years. If Mike's account earns 8% interest compounded quarterly, how much will he need to deposit each quarter during the first 15 years in order to accomplish his goal?

Chapter 7: Sets and Venn Diagrams

Chapter 7 Learning Objectives:

- Distinguish between a subset and a proper subset
- Use correct set notation and terminology
- Find intersection, unions, and complements of sets
- Model relationships between sets using Venn diagrams
- Recognize and be able to apply cardinality notation
- Use cardinality notation and formulas to solve Venn diagrams

Section 7.1 – Set Basics

Section 7.2 - Union, Intersection, and Complement

Section 7.3 - Venn Diagrams

Section 7.4 - Cardinality

Section 7.1 – Set Basics

It is natural for us to classify items into groups, or sets, and consider how those sets overlap with each other. We can use these sets to understand relationships between groups, and to analyze survey data.

An art collector might own a collection of paintings, while a music lover might keep a collection of CDs. Any collection of items can form a **set**.

Set

A **set** is a collection of distinct objects, called **elements** of the set.

A set can be defined by describing the contents, or by listing the elements of the set, enclosed in curly brackets.

Example 1

Some examples of sets that are defined by describing the contents of the set:

- a) The set of all even numbers
- b) The set of all books written about travel to Chile

Some examples of sets that are defined by listing the elements of the set:

- a) {1, 3, 9, 12}
- b) {red, orange, yellow, green, blue, indigo, purple}

A set simply specifies the contents; order is not important. The set represented by {1, 2, 3} is equivalent to the set {3, 1, 2}.

Notation

We will use a variable to represent a set, to make it easier to refer to that set later.

The symbol \in means “is an element of”.

A set that contains no elements, $\{ \}$, is called the **empty set** and is notated \emptyset .

Example 2

Let $A = \{1, 2, 3, 4\}$

To notate that 2 is element of the set, we'd write $2 \in A$

Sometimes a collection might not contain all the elements of a set. For example, Chris owns three Madonna albums. While Chris's collection is a set, we can also say it is a **subset** of the larger set of all Madonna albums.

Subset

A **subset** of a set A is another set that contains only elements from the set A , but may not contain all the elements of A .

If B is a subset of A , we write $B \subseteq A$

A **proper subset** is a subset that is not identical to the original set – it contains fewer elements.

If B is a proper subset of A , we write $B \subset A$

Example 3

Consider these three sets

$A =$ the set of all even numbers $B = \{2, 4, 6\}$ $C = \{2, 3, 4, 6\}$

Here $B \subset A$ since every element of B is also an even number, so is an element of A .

It is also true that $B \subset C$.

C is not a subset of A , since C contains an element, 3, that is not contained in A .

Example 4

Suppose a set contains the plays “Much Ado About Nothing”, “MacBeth”, and “A Midsummer’s Night Dream”. What is a larger set this might be a subset of?

There are many possible answers here. One would be the set of plays by Shakespeare. This is also a subset of the set of all plays ever written. It is also a subset of all British literature.

You Try 7.1

The set $A = \{1, 3, 5\}$. What is a larger set that this might be a subset of?

Section 7.2 - Union, Intersection, and Complement

It is very common for sets to interact. For example, you and a new roommate decide to have a house party, and you both invite your circle of friends. At this party, two sets are being combined, though it might turn out that there are some friends that were in both sets.

Union, Intersection, and Complement

The **union** of two sets contains all the elements contained in either set A, or set B, or in both sets. The union is written “ $A \cup B$ ” or “A or B”.

The **intersection** of two sets contains only the elements that are in both sets A and B. The intersection is written “ $A \cap B$ ” or “A and B”.

The **complement** of a set A contains everything that is *not* in the set A. The complement of A can be written A^c , \bar{A} , A' , not A, or sometimes $\sim A$. For consistency, this text will use \bar{A} .

Example 5

Consider the sets:

$$A = \{\text{red, green, blue}\}$$

$$B = \{\text{red, yellow, orange}\}$$

$$C = \{\text{red, orange, yellow, green, blue, purple}\}$$

$$D = \{\text{yellow, white}\}$$

a) Find $A \cup B$

The union contains all the elements in either set A or set B, or both:
 $A \cup B = \{\text{red, green, blue, yellow, orange}\}$
Notice we only list red once.

b) Find $A \cap B$

The intersection contains all the elements in both sets: $A \cap B = \{\text{red}\}$

c) Find $\bar{A} \cap C$

Here we're looking for all the elements that are *not* in set A and are also in C.
 $\bar{A} \cap C = \{\text{orange, yellow, purple}\}$

d) Find $A \cap D$.

Because set A and set B have no elements in common, we can write:
 $A \cap D = \emptyset$ or $A \cap D = \{ \}$

You Try 7.2A

Using the sets from the previous example, find $A \cup C$ and $\bar{B} \cap A$.

Notice that in the example above, it would be hard to just ask for \bar{A} since everything from the color fuchsia to puppies and peanut butter are included in the complement of the set. For this reason, complements are usually only used with intersections, or when we have a universal set in place.

Universal Set

A **universal set** is a set that contains all the elements we are interested in.
This would have to be defined by the context.

A complement is relative to the universal set, so \bar{A} contains all the elements in the universal set that are not in A.

Example 6

- If we were discussing searching for books, the universal set might be all the books in the library.
- If we were grouping your Facebook friends, the universal set would be all your Facebook friends.
- If you were working with sets of numbers, the universal set might be all whole numbers, all integers, or all real numbers.
- If you were working with letters, the universal set might include all 26 letters in the English alphabet.

Example 7

Suppose the universal set is $U =$ all whole numbers from 1 to 9.

$$\text{If } A = \{1, 2, 4\}, \text{ then } \bar{A} = \{3, 5, 6, 7, 8, 9\}$$

You Try 7.2B

Suppose the universal set is $U =$ all odd numbers from 1 to 15.

$$\text{If } A = \{1, 3, 9, 11\}, \text{ then } \bar{A} = \underline{\hspace{10em}}$$

Set Operations

As we saw earlier with the expression $\bar{A} \cap C$, set operations can be grouped together.

Grouping symbols can be used like they are with arithmetic – to force an order of operations.

Example 8

Suppose $H = \{\text{cat, dog, rabbit, mouse}\}$, $F = \{\text{dog, cow, duck, pig, rabbit}\}$
 $W = \{\text{duck, rabbit, deer, frog, mouse}\}$

a) Find $(H \cap F) \cup W$

We start with the intersection:

$$H \cap F = \{\text{dog, rabbit}\}$$

Now we union that result with W :

$$(H \cap F) \cup W = \{\text{dog, duck, rabbit, deer, frog, mouse}\}$$

b) Find $H \cap (F \cup W)$

We start with the union:

$$F \cup W = \{\text{dog, cow, rabbit, duck, pig, deer, frog, mouse}\}$$

Now we intersect that result with H :

$$H \cap (F \cup W) = \{\text{dog, rabbit, mouse}\}$$

c) Find $\overline{(H \cap F)} \cap W$

We start with the intersection: $H \cap F = \{\text{dog, rabbit}\}$

Now we want to find the elements of W that are *not* in $H \cap F$

$$\overline{(H \cap F)} \cap W = \{\text{duck, deer, frog, mouse}\}$$

Section 7.3 - Venn Diagrams

To visualize the interaction of sets, John Venn in 1880 thought to use overlapping circles, building on a similar idea used by Leonhard Euler in the 18th century. These illustrations are now called **Venn Diagrams**.

Venn Diagram

A Venn diagram represents each set by a circle, usually drawn inside of a rectangle. The rectangle represents the universal set. Overlapping areas of circles indicate elements common to both sets.

Note: There is no meaning to the size of the circle.

Basic Venn diagrams can illustrate the interaction of two or three sets

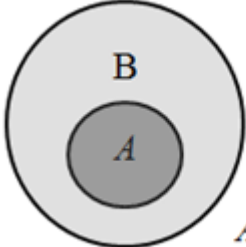
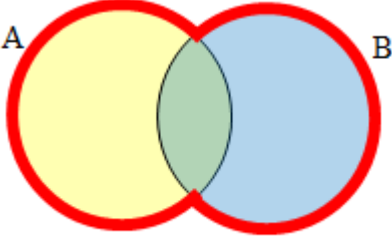
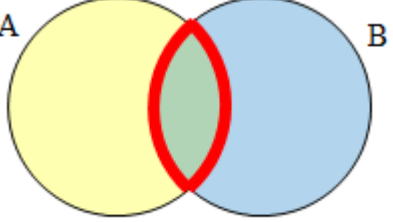
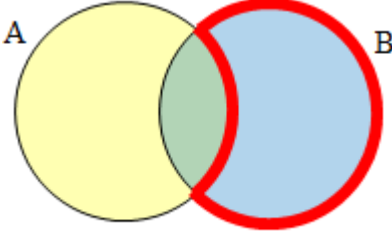
Example 9	
Create Venn diagrams to illustrate $B \subset A$, $A \cup B$, $A \cap B$, and $\bar{A} \cap B$	
<p>$A \subset B$ means that A is a proper subset of set B. So all elements in set A are also elements in Set B.</p>  <p style="text-align: right;">$A \subset B$</p>	<p>$A \cup B$ contains all elements in <i>either</i> set.</p>  <p style="text-align: center;">$A \cup B$</p>
<p>$A \cap B$ contains only those elements in both sets – in the overlap of the circles.</p>  <p style="text-align: center;">$A \cap B$</p>	<p>\bar{A} will contain all elements <i>not</i> in the set A. $\bar{A} \cap B$ will contain the elements in set B that are not in set A.</p>  <p style="text-align: center;">$\bar{A} \cap B$</p>

You Try 7.3A
Draw a Venn Diagram to represent that set G is a proper subset of set P.

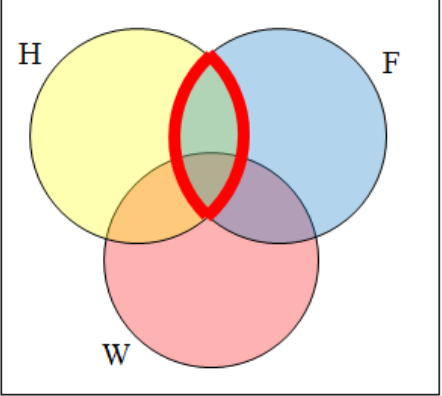
Example 10	
Use a Venn diagram to illustrate $\overline{(H \cap F)} \cap W$	
<p>We'll start by identifying everything in the set $H \cap F$</p>	

Now, $\overline{(H \cap F)} \cap W$ will contain everything *not* in the set identified above that is also in set W .

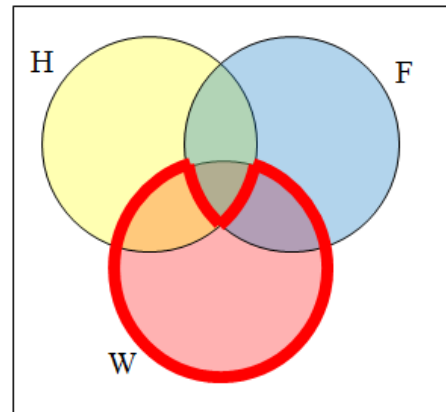

Example 11

Create an expression to represent the outlined part of the Venn diagram shown.

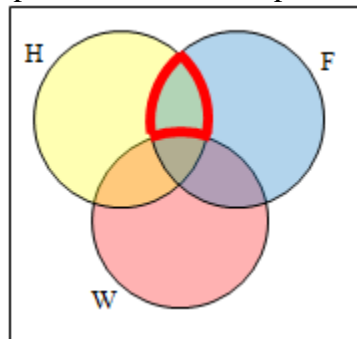

The elements in the outlined set *are* in sets H and F , but are not in set W .
So we could represent this set as $H \cap F \cap \bar{W}$

You Try 7.3B

Create an expression to represent the outlined portion of the Venn diagram shown below.

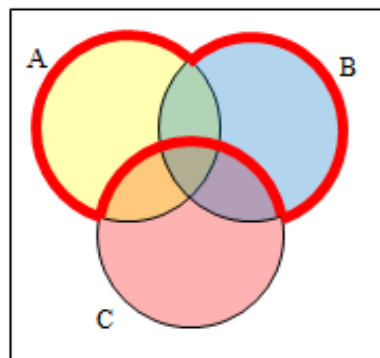

Section 7.4 - Cardinality

Often times we are interested in the number of items in a set or subset. This is called the cardinality of the set.

Cardinality
<p>The number of elements in a set is the cardinality of that set.</p> <p>The cardinality of the set A is often notated as $n(A)$.</p>

Example 12
<p>Let $A = \{1, 2, 3, 4, 5, 6\}$ and $B = \{2, 4, 6, 8\}$.</p> <p>What is the cardinality of B? $A \cup B$? $A \cap B$?</p> <p>The cardinality of B is 4, since there are 4 elements in the set.</p> <p>The cardinality of $A \cup B$ is 7, since $A \cup B = \{1, 2, 3, 4, 5, 6, 8\}$, which contains 7 elements.</p> <p>The cardinality of $A \cap B$ is 3, since $A \cap B = \{2, 4, 6\}$, which contains 3 elements.</p>

Example 13
<p>What is the cardinality of $P =$ the set of English names for the months of the year?</p> <p>The cardinality of this set is 12, since there are 12 months in the year.</p>

Example 14						
<p>Consider the Venn diagram below</p> <div style="text-align: center;">  </div> <p>Determine $n(A)$, $n(\bar{A})$, $n(B)$, $n(\bar{B})$, $n(A \cup B)$, $n(A \cap \bar{B})$.</p> <table style="width: 100%; margin-top: 20px;"> <tr> <td style="width: 50%;">$n(A) = 11 + 8 = 19$</td> <td style="width: 50%;">$n(\bar{B}) = 11 + 2 = 13$</td> </tr> <tr> <td>$n(\bar{A}) = 2 + 4 = 6$</td> <td>$n(A \cup B) = 11 + 8 + 4 = 23$</td> </tr> <tr> <td>$n(B) = 8 + 4 = 12$</td> <td>$n(A \cap \bar{B}) = 11$</td> </tr> </table>	$n(A) = 11 + 8 = 19$	$n(\bar{B}) = 11 + 2 = 13$	$n(\bar{A}) = 2 + 4 = 6$	$n(A \cup B) = 11 + 8 + 4 = 23$	$n(B) = 8 + 4 = 12$	$n(A \cap \bar{B}) = 11$
$n(A) = 11 + 8 = 19$	$n(\bar{B}) = 11 + 2 = 13$					
$n(\bar{A}) = 2 + 4 = 6$	$n(A \cup B) = 11 + 8 + 4 = 23$					
$n(B) = 8 + 4 = 12$	$n(A \cap \bar{B}) = 11$					

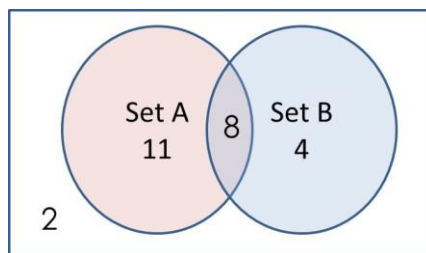

Sometimes (as in the previous example) we may be interested in the cardinality of the union or intersection of sets, but not know the actual elements of each set. This is common in surveying applications like the ones below.

Example 15

A survey asks 200 people “What beverage do you drink in the morning?”, and offers choices:

- Tea only
- Coffee only
- Both coffee and tea

Suppose 20 report tea only, 80 report coffee only, 40 report both. How many people drink tea in the morning? How many people drink neither tea nor coffee?

This question can most easily be answered by creating a Venn diagram. We can see that we can find the people who drink tea by adding those who drink only tea to those who drink both coffee and tea: 60 people.

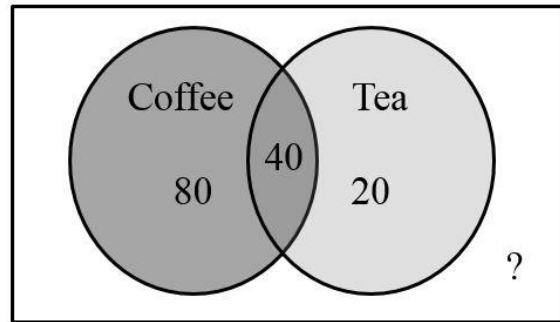

We can also see that those who drink neither are those not contained in the any of the three other groupings, so we can count those by subtracting from the cardinality of the universal set, 200.
 $200 - 20 - 80 - 40 = 60$ people who drink neither.

Example 16

A survey asks: Which online services have you used in the last month:

- Twitter
- Facebook
- Have used both

The results show 42% of those surveyed have used Twitter, 70% have used Facebook, and 20% have used both. How many people have used neither Twitter nor Facebook?

Let T be the set of all people who have used Twitter, and F be the set of all people who have used Facebook. Notice that while the cardinality of F is 70% and the cardinality of T is 42%, the cardinality of $F \cup T$ is not simply $70\% + 42\%$, since that would count those who use both services twice (and would, in this example, add up to more than 100%). To find the cardinality of $F \cup T$, we can add the cardinality of F and the cardinality of T , then subtract those in intersection that we've counted twice. In symbols,

$$n(F \cup T) = n(F) + n(T) - n(F \cap T)$$

$$n(F \cup T) = 70\% + 42\% - 20\% = 92\%$$

Now, to find how many people have not used either service, we're looking for the cardinality $n(\overline{F \cup T})$ of $\overline{F \cup T}$. Since the universal set contains 100% of people and the cardinality of $F \cup T = 92\%$, the cardinality of $\overline{F \cup T}$ must be the other 8%.

The Venn diagram for this situation would look like this:

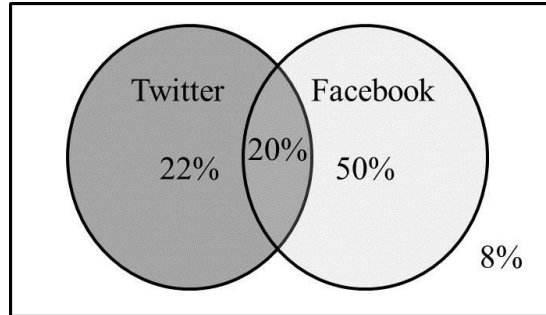

The previous example illustrated two important properties

Cardinality properties

$$n(A \cup B) = n(A) + n(B) - n(A \cap B)$$

$$n(\overline{A}) = n(U) - n(A)$$

Notice that the first property can also be written in an equivalent form by solving for the cardinality of the intersection:

$$n(A \cap B) = n(A) + n(B) - n(A \cup B)$$

You Try 7.4

In a survey of 115 pet owners, 26 said they own a dog, and 64 said they own a cat. 5 said they own both a dog and a cat. Use a Venn diagram to determine how many of the pet owners surveyed owned neither a cat nor a dog?

Chapter 7 – Answers to You Try Problems

7.1. There are several answers: The set of all odd numbers less than 10. The set of all odd numbers. The set of all integers. The set of all real numbers.

7.2A. $A \cup C = \{\text{red, orange, yellow, green, blue purple}\}$ $\overline{B} \cap A = \{\text{green, blue}\}$

7.2B. $\bar{A} = \{5, 7, 13, 15\}$

7.3A. G is a proper subset of P, so G must be completely contained within P.

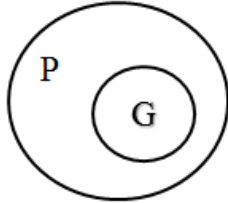

7.3B. $(A \cup B) \cap \bar{C}$

7.4. 30 owned neither a cat nor a dog

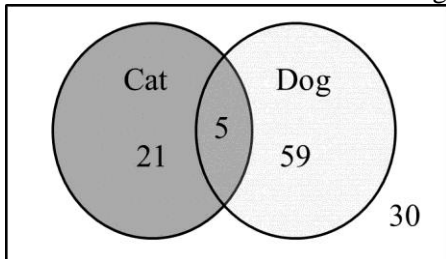

Chapter 7 – Practice Problems

1. List out the elements of the set “The letters of the word Mississippi”.
2. List out the elements of the set “Months of the year”.
3. Write a verbal description of the set $\{3, 6, 9\}$.
4. Write a verbal description of the set $\{a, i, e, o, u\}$.
5. Is $\{6, 8, 10\}$ a subset of the set of even integers?
6. Is $\{15, 23, 31\}$ a subset of the set of odd integers?
7. Is $\{A, B, C\}$ a subset of the set of letters of the alphabet?
8. Consider the sets:
 $A = \{1, 2, 3, 4, 5\}$ $B = \{1, 3, 5\}$ $C = \{4, 6\}$ $D = \{\text{numbers from 0 to 10}\}$

Indicate if each statement is true or false.

- a. $3 \in B$
 - b. $5 \in C$
 - c. $B \subset A$
 - d. $C \subset A$
 - e. $C \subset B$
 - f. $A \subset D$
 - g. $A \subset B$
9. Consider the sets:
 $A = \{1, 3, 7\}$ $B = \{3, 5, 7, 9\}$ $C = \{1, 3, 4, 7, 8, 9\}$ $D = \{\text{odd from 0 to 10}\}$

Indicate if each statement is true or false.

- a. $10 \in D$
- b. $7 \in A$
- c. $A \subset C$
- d. $A \subset D$
- e. $B \subset C$
- f. $B \subset D$
- g. $C \subset D$

10. Let set A represent all students currently attending college in Arizona and let set B represent all students currently attending Scottsdale Community College. Use set notation to describe the relationship between the two sets A and B .
11. Let set A represent all cookies, let set B represent chocolate chip cookies, and let C represent all desserts. Indicate if each statement is true or false.
- “sugar cookies” $\in C$
 - “sugar cookies” $\in B$
 - “chocolate cake” $\in C$
 - $B \subset A$
 - $C \subset B$
 - $A \subset C$
12. Suppose the universal set is $U = \{1, 2, 3, \dots, 8, 9, 10\}$. If $A = \{5, 6, 8\}$, find \bar{A} .
13. Suppose the universal set is $U = \{\text{red, orange, yellow, green, blue, purple}\}$. If $A = \{\text{red, green, blue}\}$, find \bar{A} .
14. Suppose the universal set U is all even numbers from 2 to 20. If $A = \{4, 6, 10, 16, 18, 20\}$, find \bar{A} .
15. Let $U = \{1, 2, 3, \dots, 18, 19, 20\}$ be the universal set. Consider the sets:
 $A = \{2, 3, 5, 7, 10, 11, 12, 13, 14, 16, 17, 19\}$ $B = \{5, 10, 13, 14, 16, 19, 20\}$

Find each of the following:

- $A \cup B$
- $A \cap B$
- $\bar{A} \cap B$

16. Let $U = \{1, 2, 3, \dots, 18, 19, 20\}$ be the universal set. Consider the sets:
 $A = \{6, 11, 12, 14, 16, 17, 18\}$ $B = \{1, 4, 5, 8, 11, 12, 15, 16\}$

Find each of the following:

- $A \cup B$
- $A \cap B$
- $A \cap \bar{B}$

17. Let $U = \{1, 2, 3, \dots, 18, 19, 20\}$ be the universal set. Consider the sets:
 $A = \{1, 2, 3, 4, 6, 8, 9, 11, 12, 14, 15, 18\}$ $B = \{5, 9, 12, 14, 17, 19, 20\}$

Find each of the following:

- a. $A \cup B$
- b. $A \cap B$
- c. $\bar{A} \cap B$

18. Let $U = \{1, 2, 3, \dots, 8, 9, 10\}$ be the universal set. Consider the sets:
 $A = \{3, 5, 8, 10\}$ $B = \{1, 3, 4, 7, 8, 9, 10\}$ $C = \{2, 5, 6\}$

Find each of the following:

- a. $A \cup C$
- b. $B \cap C$
- c. $A \cap \bar{B}$
- d. $\overline{(A \cup C)}$
- e. $\overline{(A \cap B)} \cup C$

19. Let $D = \{b, a, c, k\}$, $E = \{t, a, s, k\}$, $F = \{b, a, t, h\}$. Using these sets, find the following: (Hint: first determine the elements in the universal set)

- a. $\bar{D} \cap E$
- b. $\bar{F} \cap D$
- c. $(D \cap E) \cup F$
- d. $D \cap (E \cup F)$
- e. $\overline{(F \cap E)} \cap D$
- f. $\overline{(D \cup E)} \cap F$

For **problems 20 – 30**, create a Venn diagram to illustrate each of the following

20. \bar{C}
21. $A \cup B$
22. $A \cap B$
23. $A \cap \bar{B}$
24. $A \cup B \cup C$
25. $A \cap B \cap C$
26. $(A \cup B) \cap C$
27. $(C \cap B) \cup A$
28. $\overline{(C \cap A)} \cap B$
29. $\overline{(A \cup B)} \cap C$
30. $(\bar{A} \cap \bar{B}) \cap C$

For **problems 31 – 34**, write an expression for the shaded region.

31.

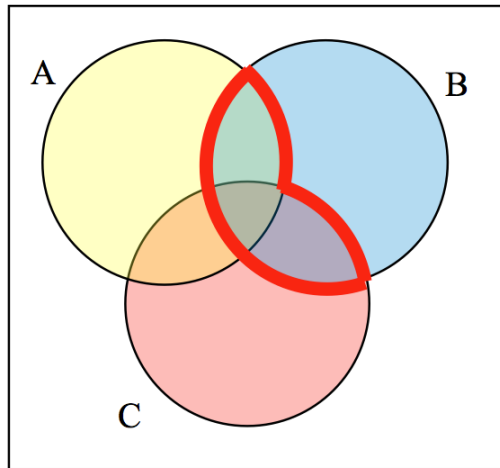

32.

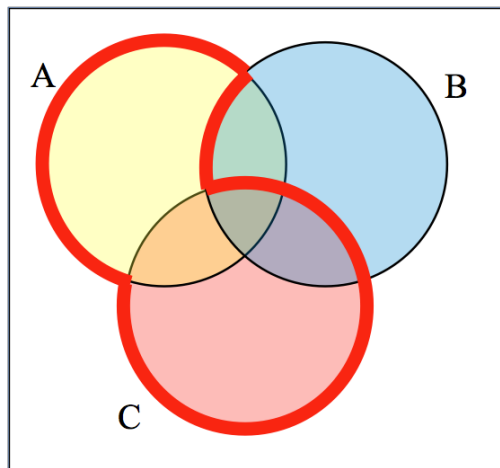

33.

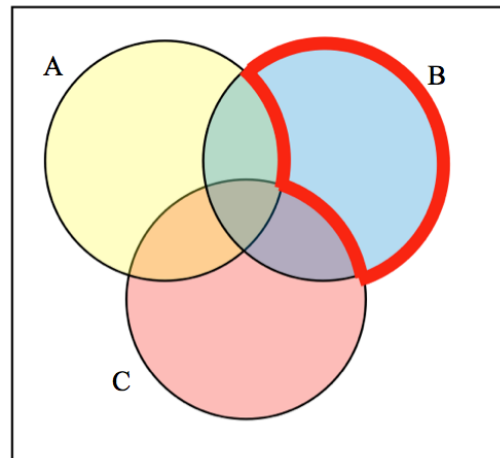

34.

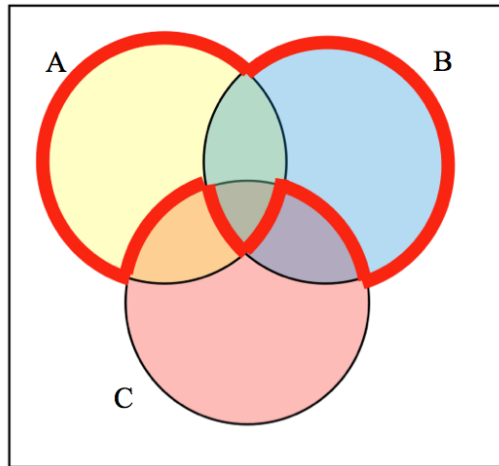
35. Let $A = \{1, 2, 3, 4, 5\}$ $B = \{1, 3, 5\}$ $C = \{4, 6\}$

- What is the cardinality of A ?
- What is the cardinality of B ?
- What is the cardinality of $A \cup C$?
- What is the cardinality of $A \cap C$?

36. Let $A = \{1, 5, 9\}$ $B = \{1, 2, 3, 4, 5, 6, 8\}$ $C = \{2, 4, 5, 8, 9\}$

Determine the following:

- $n(A)$
- $n(C)$
- $n(B)$
- $n(B \cap C)$
- $n(A \cup C)$

37. Consider the Venn diagram below.

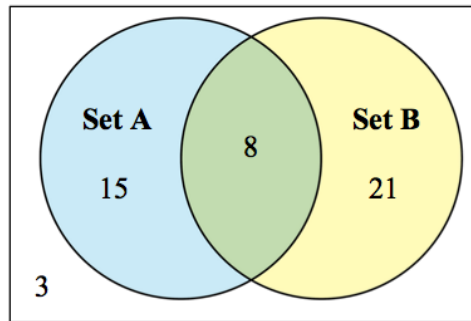

Determine the following:

- a. $n(A)$
- b. $n(\bar{A})$
- c. $n(B)$
- d. $n(\bar{B})$
- e. $n(A \cap B)$
- f. $n(A \cup B)$
- g. $n(\bar{A} \cap B)$

38. Consider the Venn diagram below.

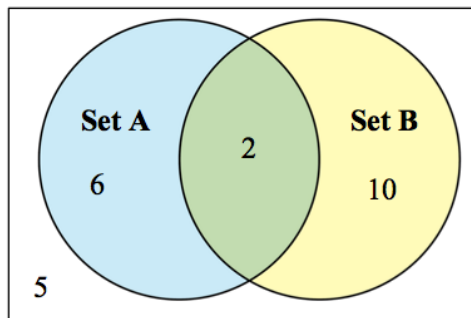

Determine the following:

- a. $n(A)$
- b. $n(\bar{A})$
- c. $n(B)$
- d. $n(\bar{B})$
- e. $n(A \cap B)$
- f. $n(A \cup B)$
- g. $n(\bar{A} \cap \bar{B})$

39. Consider the Venn diagram below.

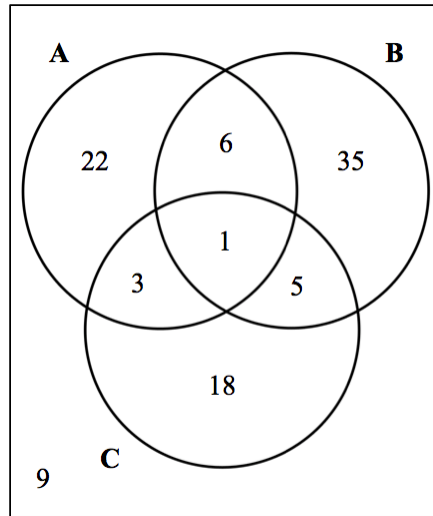

Determine the following

- a. $n(A)$
 - b. $n(C)$
 - c. $n(\bar{B})$
 - d. $n(A \cap C)$
 - e. $n(B \cup C)$
 - f. $n((B \cap C) \cup A)$
40. In a survey of 90 pet owners, 15 said they own a dog, and 49 said they own a cat. 6 said they own both a dog and a cat. How many owned a cat but not a dog?
41. In a survey of 121 pet owners, 55 said they own a dog, and 84 said they own a cat. 47 said they own both a dog and a cat. How many owned a dog but not a cat?
42. In a survey of 112 pet owners, 77 said they own a dog, and 33 said they own a cat. 20 said they own both a dog and a cat. How many owned neither a cat nor a dog?
43. Out of 60 students, 21 are taking English, 34 are taking Math, and 7 are in both classes.
- a. Draw a Venn diagram to organize the information.
 - b. How many students are in either English or Math?
 - c. How many students are not in English?
 - d. How many students are in English and not in Math?

44. Students who take AP English also take the AP test, of which they either pass or fail. Of the 28 students taking AP English, 10 received an A in the course. Out of the 15 students that passed the AP exam, 9 received an A.
- Draw a Venn diagram to organize the information.
 - How many students failed the AP exam?
 - How many students passed the AP exam and did not receive an A?
 - How many students failed the AP exam and did not receive an A?
45. There are 72 people at an event. Out of the 34 men in attendance, 19 are fathers. There are 41 total parents.
- Draw a Venn diagram to organize the information.
 - How many of the people are mothers?
 - How many women are not mothers?
46. The following Venn diagram shows students in various college courses.

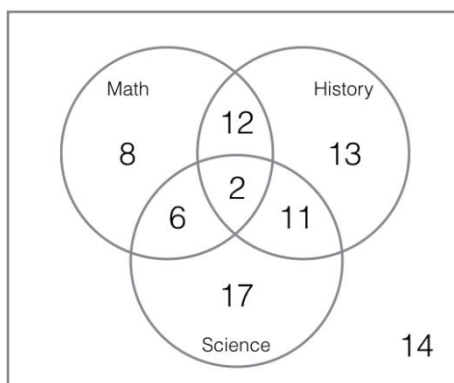

- How many students are taking Math?
- How many students are taking Math and Science?
- How many students are taking History and Science, but not Math?

47. The following Venn diagram shows cars in a parking lot.

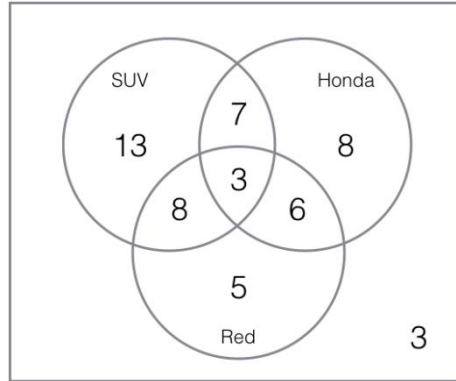

- How many Hondas are in the parking lot?
- How many red SUVs are in the parking lot?
- How many of the Red cars in the parking lot are not Hondas?

48. The following Venn diagram shows people at a party.

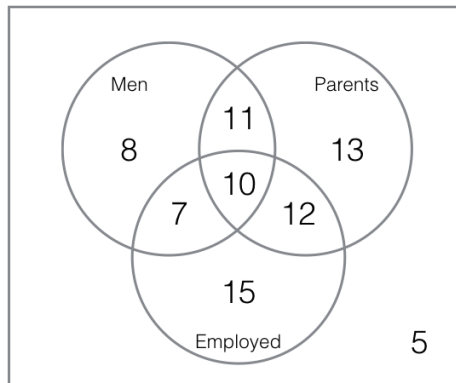

- How many people at the party are employed?
- How many people at the party are mothers?
- How many people at the party are working fathers?
- How many people at the party are not parents?

49. A survey was given to students asking whether they watch movies at home from Netflix, Redbox, or a video store. Use the results to determine how many people use Redbox.

- | | |
|--------------------------------|---------------------------------------|
| 52 only use Netflix | 62 only use Redbox |
| 24 only use a video store | 16 use only a video store and Redbox |
| 48 use only Netflix and Redbox | 30 use only a video store and Netflix |
| 10 use all three | 25 use none of these |

50. A survey asked buyers whether color, size, or brand influenced their choice of cell phone. The results are below. How many people were influenced by brand?

5 only said color	8 only said size
16 only said brand	20 said only color and size
42 said only color and brand	53 said only size and brand
102 said all three	20 said none of these

51. A survey asked people what alternative transportation modes they use. Use the data to complete a Venn diagram, then determine:

- what percent of people only ride the bus
 - how many people don't use any alternate transportation
- | | |
|-----------------------------|-----------------------------------|
| 30% use the bus | 20% ride a bicycle |
| 25% walk | 5% use the bus and ride a bicycle |
| 10% ride a bicycle and walk | 12% use the bus and walk |
| 2% use all three | |

Chapter 8 – Introduction to Probability

Chapter 8 Learning Objectives:

- Distinguish between subjective, experimental, and theoretical probabilities
- Be familiar with probability terminology and properties of probabilities
- Use the complement formula to find probabilities
- Be able to calculate odds for and/or against an event
- Create tables to calculate expected values for real world applications including insurance and product warranties

Section 8.1 – Types of Probability

Section 8.2 – Basic Concepts

Section 8.3 – Complementary Events

Section 8.4 – Calculating Odds

Section 8.5 – Expected Value

Section 8.1 – Types of Probability

The probability of a specified event is the chance or likelihood that it will occur. There are several ways of viewing probability. One would be **subjective** in nature, in other words an educated guess. If someone asked you the probability that the Seattle Mariners would win their next baseball game, it would be impossible to conduct an experiment where the same two teams played each other repeatedly, each time with the same starting lineup and starting pitchers, each starting at the same time of day on the same field under the precisely the same conditions. Since there are so many variables to take into account, someone familiar with baseball and with the two teams involved might make an educated guess that there is a 75% chance they will win the game; that is, *if* the same two teams were to play each other repeatedly under identical conditions, the Mariners would win about three out of every four games. But this is just a guess, with no way to verify its accuracy, and depending upon how educated the educated guesser is, a subjective probability may not be worth very much. Let's consider two other types of probabilities.

Another view of probability would be **experimental** in nature, where we repeatedly conduct an experiment. Suppose we flipped a coin over and over and over again and it came up heads about half of the time; we would expect that in the future whenever we flipped the coin it would turn up heads about half of the time. When a weather reporter says "there is a 10% chance of rain tomorrow," she is basing that on prior evidence; that out of all days with similar weather patterns, it has rained on 1 out of 10 of those days.

We will return to the subjective and experimental probabilities from time to time, but in this course we will mostly be concerned with **theoretical** probability, which is defined as follows:

Theoretical Probability

Suppose there is a situation with n equally likely possible outcomes and that m of those n outcomes correspond to a particular event; then the **probability** of that event is defined

$$\text{as } \frac{m}{n}.$$

$$\text{Probability of an event} = \frac{\text{number of ways the event can occur}}{\text{total number of possible outcomes}}$$

Let's return to the coin flipping example. Instead of calculating the probability of the coin landing on heads by flipping a coin many times and observing the number of heads (which is an experimental probability) we could instead use what we know about coins. A fair coin has 2 equally likely possible outcomes: heads or tails. If we are interested in calculating the theoretical probability of a coin landing on heads, we could do so using the formula above: $\frac{\text{number of ways a head can occur}}{\text{number of possible outcomes}} = \frac{1}{2}$.

Section 8.2 – Basic Concepts

If you roll a die, pick a card from deck of playing cards, or randomly select a person and observe their hair color, we are executing an experiment or procedure. In probability, we look at the likelihood of different outcomes. We begin with some terminology.

Events and Outcomes

The result of an experiment is called an **outcome**.

An **event** is any particular outcome or group of outcomes.



A **simple event** is an event that cannot be broken down further.

The **sample space** is the set of all possible outcomes.

Example 1

If we roll a standard 6-sided die, describe the sample space and some simple events.

The sample space is the set of all possible outcomes: {1,2,3,4,5,6}

<p>Some examples of simple events: We roll a 1 We roll a 5</p>		
<p>Some examples of events: We roll a number bigger than 4</p>	Two dice	One die

Basic Probability

Given that all outcomes are equally likely, we can compute the probability of an event E using this formula:

$$P(E) = \frac{\text{Number of outcomes corresponding to the event } E}{\text{Total number of equally likely outcomes}}$$

Example 2

If we roll a 6-sided die, calculate

- a) $P(\text{rolling a } 1)$
- b) $P(\text{rolling a number bigger than } 4)$

Recall that the sample space is $\{1,2,3,4,5,6\}$

- a) There is one outcome corresponding to “rolling a 1”, so the probability is $\frac{1}{6}$
- b) There are two outcomes bigger than a 4, so the probability is $\frac{2}{6} = \frac{1}{3}$

You Try 8.2A

If we roll a 6-sided die, calculate $P(\text{rolling an odd number})$.

Probabilities are essentially fractions, and can be reduced to lower terms like fractions.

Example 3

Let's say you have a bag with 20 cherries, 14 sweet and 6 sour. If you pick a cherry at random, what is the probability that it will be sweet?

There are 20 possible cherries that could be picked, so the number of possible outcomes is 20. Of these 20 possible outcomes, 14 are favorable (sweet), so the probability that the cherry will be sweet is $\frac{14}{20} = \frac{7}{10}$.

There is one potential complication to this example, however. It must be assumed that the probability of picking any of the cherries is the same as the probability of picking any other. This wouldn't be true if (let us imagine) the sweet cherries are smaller than the sour ones. (The sour cherries would come to hand more readily when you sampled from the bag.) Let us keep in mind, therefore, that when we assess probabilities in terms of the ratio of favorable to all potential cases, we rely heavily on the assumption of equal probability for all outcomes.

You Try 8.2B

At some random moment, you look at your clock and note the minutes reading.

- What is probability the minutes reading is 15?
- What is the probability the minutes reading is 15 or less?

Cards

A standard deck of 52 playing cards consists of four **suits** (hearts, spades, diamonds and clubs). Spades and clubs are black while hearts and diamonds are red. Each suit contains 13 cards, each of a different **rank**: an Ace (which in many games functions as both a low card and a high card), cards numbered 2 through 10, a Jack, a Queen and a King. The Jack, Queen, and King are called **face cards**.

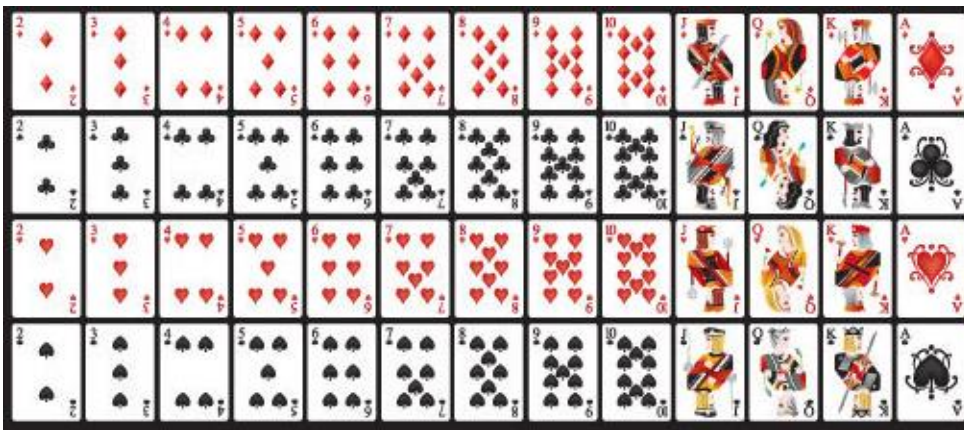

This file originated at Vector4Free.com and is distributed under the Creative Commons License (CC BY 4.0). For more info visit [Creative Commons.org/licenses/by/4.0/](http://creativecommons.org/licenses/by/4.0/)
<http://vector4free.com/vector/free-vector-playing-cards-deck/>

Example 4

Compute the probability of randomly drawing one card from a deck and getting an Ace.

There are 52 cards in the deck and 4 Aces so $P(\text{Ace}) = \frac{4}{52} = \frac{1}{13} \approx 0.0769$

We can also think of probabilities as percents: There is a 7.69% chance that a randomly selected card will be an Ace.

Notice that the smallest possible probability is 0 (there are no outcomes that correspond with the event). The largest possible probability is 1 (all possible outcomes correspond with the event).

Certain and Impossible events
An impossible event has a probability of 0.
A certain event has a probability of 1.
The probability of any event must be $0 \leq P(E) \leq 1$

In the course of this chapter, if you compute a probability and get an answer that is negative or greater than 1, you have made a mistake and should check your work.

Example 5
Find the probability of drawing a single card from a deck and getting a red spade.
There are 52 cards in the deck, but all spades are black. It is impossible to draw a single card and have that card be a red spade. This is an impossible event, so
$P(\text{red spade}) = \frac{0}{52} = 0.$

Example 6
You wake up on a cloudy, drizzly Seattle day to the weatherman saying the chance of rain today is 100%. Find the probability that it will rain today.
Since we are told the chance of rain is 100%, we know that this is a certain event.
$P(\text{rain}) = \frac{100}{100} = 1$

You Try 8.2C
Your neighbor tells you that he heard on the radio that the probability of an earthquake of magnitude 7.0 or higher hitting California in the next 10 years is 1.2. How do you know that this is incorrect?

Section 8.3 – Complementary Events

Now let us examine the probability that an event does **not** happen. As in the previous section, consider the situation of rolling a six-sided die and first compute the probability of rolling a six: the answer is $P(\text{six}) = 1/6$. Now consider the probability that we do *not* roll a six: there are 5 outcomes that are not a six, so the answer is $P(\text{not a six}) = \frac{5}{6}$.

Notice that $P(\text{six}) + P(\text{not a six}) = \frac{1}{6} + \frac{5}{6} = \frac{6}{6} = 1$ This is not a coincidence.

Complement of an Event

The **complement** of an event is the event “ E does NOT happen”.

The notation \bar{E} is used for the complement of event E . You should recognize this notation from the last chapter.

$$\text{For any event } E, P(E) + P(\bar{E}) = 1$$

We can compute the probability of the complement using $P(\bar{E}) = 1 - P(E)$

$$\text{Notice also that } P(E) = 1 - P(\bar{E})$$

Example 7

If you pull a random card from a deck of playing cards, what is the probability it is not a heart?

There are 13 hearts in the deck, so $P(\text{heart}) = \frac{13}{52} = \frac{1}{4}$.

The probability of *not* drawing a heart is the complement:

$$P(\text{not heart}) = 1 - P(\text{heart}) = 1 - \frac{1}{4} = \frac{3}{4}$$

Example 8

A jar contains 28 marbles, 12 of which are red. If you pick 1 marble out of the jar, what is the probability that it is not red?

There are 12 red marbles out of 28 total marbles, so $P(\text{red}) = \frac{12}{28} = \frac{3}{7}$.

The probability of *not* drawing a red marble is the complement:

$$P(\text{not red}) = 1 - \frac{3}{7} = \frac{4}{7}$$

You Try 8.3

Your favorite basketball player is an 84% free throw shooter. Find the probability that he does NOT make his next free throw.

Section 8.4 – Calculating Odds

We frequently think of the terms probability and odds in the same way. This is correct to some extent, as both terms attempt to identify the likelihood of a certain event or

outcome. However, mathematically probability and odds mean two different things, and are expressed differently. As you now know, a probability is a fraction representing the number of ways a particular event can occur divided by the total number of possible outcomes. We will now explore the meaning of odds, and converting between probabilities and odds.

Finding Odds For an Event

Another way besides probability to talk about the chances of an event occurring is with **odds**. You may have heard of the phrases “fifty-fifty” or “even odds” to describe an unpredictable situation like the chances of getting heads when you toss a coin. The phrase means that the coin is as likely to come up tails as it is heads (each event occurring 50% of the time), but odds are not generally expressed as a fraction or a percentage.

The **odds** of an event are given by the *ratio* of the number of times the event occurs to the number of times the event *does not* occur.

Odds For (in favor of) an Event

Odds = number of ways event can occur : number of ways event cannot occur

We can also calculate odds using probabilities:

$$\text{Odds} = \frac{P(E)}{P(\text{not } E)}$$

To avoid confusion with probability, odds are usually left as a ratio such as 1:5, which would be read as “one **to** five”. When *probability* is read as a ratio, it’s usually written as a fraction like $\frac{1}{5}$, which would usually be read as “one **in** five.”

Example 9

Find the odds for the event of tossing a coin and getting heads.

Solution 1:

The key to finding odds is looking at how many outcomes result in the event and how many **do not**.

The sample space consists of 2 outcomes: heads or tails. The event we are interested in is the event that the coin lands on heads. There is 1 way the event can occur (the coin lands on heads) and there is 1 way the event can NOT occur (the coin lands on tails).

The odds for getting heads are 1 : 1

We call those odds *one to one*, or *even*. We are just as likely to get a head as to not get a head.

Solution 2 (Using the probability method):

We are going to answer the question this time using the probability definition for finding odds.

$$\text{The odds for getting heads} = \frac{P(\text{heads})}{P(\text{not heads})} = \frac{\frac{1}{2}}{\frac{1}{2}} = \frac{1}{1}.$$

We would write the odds for getting heads as 1 to 1, or 1 : 1 (*one to one*).

Example 10

Find the odds for rolling a die and getting a 3.

Odds for getting a 3 = number of ways to get a 3 : number of ways to not get a 3

Odds for getting a 3 = 1 : 5

Using the probability method:

$$\text{Odds for getting a 3} = \frac{P(3)}{P(\text{not } 3)} = \frac{\frac{1}{6}}{\frac{5}{6}} = \frac{1}{5} = 1 : 5 \text{ (one to five).}$$

Look carefully at the example above. This illustrates the need to avoid confusion between odds and probability. We know that the *probability* of getting a 3 is $P(3) = \frac{1}{6}$ or “*one in six*,” but the *odds* describes the same event with the ratio 1 : 5 or “*one to five*”.

You Try 8.4A

A board game has a spinner that is divided into 8 different colored sections. The sections are red, orange, yellow, green, blue, purple, black, and white. Find the odds of the spinner landing on a primary color (red, yellow, or blue).

Example 11

You are told that the probability of a tornado hitting your hometown during the month of May is 0.15. Find the odds for a tornado hitting your hometown during May.

$$\text{Odds for a tornado} = \frac{P(\text{tornado})}{P(\text{no tornado})} = \frac{0.15}{1-0.15} = \frac{0.15}{0.85} = 0.18 \quad (18 \text{ hundredths})$$

Odds for a tornado = 18 : 100 which can be reduced to 9 : 50 (*nine to fifty*).

Example 12

Find the odds for tossing 4 coins and getting exactly 3 tails.

In this example, we first need to determine what all of the possible outcomes are when you toss 4 coins. Here is a list of all possible outcomes when tossing 4 coins:

HHHH	HHHT	HHTT	HTTT
THTH	TTHH	THHT	HTHH
TTTT	TTHH	TTHH	TTHH
HTHT	HHTH	HTTH	THTT

There are 4 outcomes where exactly 3 tails came up and 12 outcomes when they did not. So the odds for getting **3 tails** are $4 : 12 = 1 : 3$ (*one to three*).

Finding Odds Against an Event

Most gambling applications involve calculating and reporting the odds against an event. The **odds against** an event are given by a *ratio*, just like the odds for an event.

Since we now want the odds against an event occurring, we create a ratio of the number of times the event *does not* occur to the number of times the event *does* occur.

Odds Against an Event

Odds = number of ways event cannot occur : number of ways event can occur

We can also calculate odds using probabilities:

$$\text{Odds} = \frac{P(\text{not } E)}{P(E)}$$

Example 13

Find the odds against tossing 4 coins and getting exactly 3 tails.

In the previous example we calculated the odds for this event. Now we want to calculate the odds against it. Recall, the sample space contains 4 outcomes where exactly 3 tails came up and 12 outcomes when they did not.

Since we are looking for the odds against tossing 4 coins and getting exactly 3 tails, we need to take the ratio of the number of ways we do not get exactly 3 tails to the number of ways we do get exactly 3 tails.

Odds against getting exactly 3 tails = $12 : 4 = 3 : 1$ (*three to one*).

Example 14

Experts calculate the probability of a particular horse winning the Kentucky Derby to be 0.2. Calculate the odds against the horse winning the race.

$$\frac{P(\text{not winning})}{P(\text{winning})} = \frac{1-0.2}{0.2} = \frac{0.8}{0.2} = \frac{4}{1} = 4 : 1 \text{ (four to one).}$$

You Try 8.4

- Find the odds **for** drawing a club from a standard 52-card deck.
- Find the odds **against** drawing a club from a standard 52-card deck.

Section 8.5 – Expected Value

Expected value is perhaps the most useful probability concept we will discuss. It has many applications, from insurance policies to making financial decisions, and it's one thing that the casinos and government agencies that run gambling operations and lotteries hope most people never learn about.

Example 15

⁶In the casino game roulette, a wheel with 38 spaces (18 red, 18 black, and 2 green) is spun. In one possible bet, the player bets \$1 on a single number. If that number is spun on the wheel, then they receive \$36 (their original \$1 + \$35). Otherwise, they lose their \$1. On average, how much money should a player expect to win or lose if they play this game repeatedly?



Suppose you bet \$1 on each of the 38 spaces on the wheel, for a total of \$38 bet. When the winning number is spun, you are paid \$36 on that number. While you won on that one number, overall you've lost \$2. On a per-space basis, you have "won" $-\$2/\$38 \approx -\$0.053$. In other words, on average you lose 5.3 cents per space you bet on.

We call this average gain or loss the **expected value** of playing roulette. Notice that no one ever loses exactly 5.3 cents: most people (in fact, about 37 out of every 38) lose \$1 and a very few people (about 1 person out of every 38) gain \$35 (the \$36 they win minus the \$1 they spent to play the game).

⁶ Photo CC-BY-SA <http://www.flickr.com/photos/stoneflower/>

Example 16

Refer back to the roulette example. The wheel that is spun has 38 spaces (18 red, 18 black, and 2 green). In one possible bet, the player bets \$1 on a single number. If that number is spun on the wheel, then they receive \$36 (their original \$1 + \$35). Otherwise, they lose their \$1. On average, how much money should a player expect to win or lose if they play this game repeatedly?



There is another way to compute expected value without imagining what would happen if we play every possible space. There are 38 possible outcomes when the wheel spins, so the probability of winning is $\frac{1}{38}$. The complement, the probability of losing, is $\frac{37}{38}$.

Notice that if we multiply each outcome by its corresponding probability we get $\$35 \cdot \frac{1}{38} = 0.9211$ and $-\$1 \cdot \frac{37}{38} = -0.9737$, and if we add these numbers we get $0.9211 + (-0.9737) \approx -0.053$, which is the expected value of the game.

Outcome	Probability of outcome	Outcome x Probability
\$35	$\frac{1}{38}$	$\$35 \left(\frac{1}{38} \right) = \0.9211
-\$1	$\frac{37}{38}$	$-\$1 \left(\frac{37}{38} \right) = -\0.9737
		Expected Value $0.9211 + (-0.9737) \approx -0.053$

If we play roulette many times, we can expect that on average we will lose \$0.053 per play. This expected value is negative, which indicates that on average we will lose money.

Expected Value

Expected Value is the average gain or loss of an event if the procedure is repeated many times.

We can compute the expected value by multiplying each outcome by the probability of that outcome, then adding up the products.

In general, if the expected value of a game is negative, it is not a good idea to play the game, since on average you will lose money. It would be better to play a game with a positive expected value (good luck trying to find one!), although keep in mind that even if the *average* winnings are positive it could be the case that most people lose money and one very fortunate individual wins a great deal of money. If the expected value of a game is 0, we call it a **fair game**, since neither side has an advantage.

Not surprisingly, the expected value for casino games is negative for the player, which is positive for the casino. It must be positive or they would go out of business. Players just need to keep in mind that when they play a game repeatedly, their expected value is negative. That is fine so long as you enjoy playing the game and think it is worth the cost. But it would be wrong to expect to come out ahead.

You Try 8.5

A raffle ticket costs \$3. There is 1 winning ticket out of the 150 tickets sold. The winner gets \$300. What is the expected value (to you) of the raffle ticket? Should you buy a ticket?

Expected value also has applications outside of gambling. Expected value is very common in making insurance decisions.

Example 17

A 40-year-old man in the U.S. has a 0.242% risk of dying during the next year⁷. An insurance company charges \$275 for a life-insurance policy that pays a \$100,000 death benefit. What is the expected value for the person buying the insurance?

The probabilities and outcomes are

Outcome	Probability of outcome	Outcome x Probability
$\$100,000 - \$275 = \$99,725$	0.00242	\$241.33
$-\$275$	$1 - 0.00242 = 0.99758$	$-\$274.33$
		Expected Value = $-\$33$

Not surprisingly, the expected value is negative; the insurance company can only afford to offer policies if they, on average, make money on each policy. They can afford to pay out the occasional benefit because they offer enough policies that those benefit payouts are balanced by the rest of the insured people.

For people buying the insurance, there is a negative expected value, but there is a security that comes from insurance that is worth that cost.

Example 18

Consider the same problem we just did, but we will answer it using a slightly different setup.

A 40-year-old man in the U.S. has a 0.242% risk of dying during the next year⁸. An insurance company charges \$275 for a life-insurance policy that pays a \$100,000 death benefit. What is the expected value for the person buying the insurance?

⁷ According to the estimator at <http://www.numericalexample.com/index.php?view=article&id=91>

⁸ According to the estimator at <http://www.numericalexample.com/index.php?view=article&id=91>

The man will pay \$275 for the policy whether or not he dies in the next year, so the probability of losing the \$275 is 100%.

The probabilities and outcomes are

Outcome	Probability of outcome	Outcome x Probability
-\$275	1	-\$275
\$100,000	0.00242	\$242
		Expected Value = -\$33

The expected value is $(-\$275)(1) + (\$100,000)(0.00242) = -\$33$.

Example 19

A company estimates that 0.3% of their products will fail after the original warranty period but within 2 years of the purchase, with a replacement cost of \$500. If they offer a 2 year extended warranty for \$40, what is the company's expected value of each warranty sold?

The company will receive the \$40 for the warranty whether or not the product fails, so the probability of receiving the \$40 is 100%. The company has a 0.3% chance of having to pay the \$500 replacement cost if the product fails.

The expected value (to the company) is $\$40(1) + (-\$500)(0.003) = \$38.50$

On average, the company will earn \$38.50 for each policy sold.

Chapter 8 – Answers to You Try Problems

8.2A. $P(\text{rolling an odd}) = 3/6 = 1/2$

8.2B. a. $1/60$ b. $16/60$

8.2C. Probabilities must be between 0 and 1, so a probability of 1.2 is impossible.

8.3. $1 - 0.84 = 0.16$

8.4A. $3 : 5$

8.4B. a. $1 : 3$ b. $3 : 1$

8.5. The expected value of the raffle ticket is $-\$1$. You should expect to lose \$1 for each ticket that you buy. You shouldn't buy a ticket.

Chapter 8 – Practice Problems

1. Suppose you roll a six-sided die. Determine the following:
 - a. $P(\text{rolling a } 5)$
 - b. $P(\text{rolling an even number})$
 - c. $P(\text{rolling a number bigger than } 2)$
2. Compute the probability of tossing a six-sided die and getting a 7.
3. Compute the probability of tossing a six-sided die and getting a number less than 3.
4. Compute the probability of rolling a 12-sided die and getting a number other than 8.
5. A test was given to a group of students. The grades and gender are summarized below.

	A	B	C	Total
Male	8	18	13	39
Female	10	4	12	26
Total	18	22	25	65

- a. Find the probability that a student chosen at random was female.
 - b. Find the probability that a student chosen at random did NOT earn a C?
6. The table below shows the number of credit cards owned by a group of individuals.

	Zero	One	Two or more	Total
Male	9	5	19	33
Female	18	10	20	48
Total	27	15	39	81

- a. Find the probability that a person chosen at random had no credit cards.
 - b. Find the probability that a person chosen at random has at least one credit card?
7. A ball is drawn randomly from a jar that contains 6 red balls, 2 white balls, and 5 yellow balls. Find the probability of the given event.
 - a. A red ball is drawn
 - b. A white ball is drawn
8. A bag contains 2 gold marbles, 10 silver marbles, and 25 black marbles. You randomly select one marble from the bag. What is the probability that you select a gold marble?

9. Suppose you write each letter of the alphabet on a different slip of paper and put the slips into a hat. What is the probability of drawing one slip of paper from the hat at random and getting:
 - a. A consonant
 - b. A vowel
10. A group of people were asked if they had run a red light in the last year. 150 responded "yes", and 185 responded "no". Find the probability that if a person is chosen at random, they have run a red light in the last year.
11. In a survey, 205 people indicated they prefer cats, 160 indicated they prefer dogs, and 40 indicated they don't enjoy either pet. Find the probability that if a person is chosen at random, they prefer cats.
12. If you pick one card at random from a standard deck of 52 cards, what is the probability it will be a King?
13. If you pick one card at random from a standard deck of 52 cards, what is the probability it will be a Diamond?
14. If you pick one card at random from a standard deck of 52 cards, what is the probability it is not the Ace of Spades?
15. If you pick one card at random from a standard deck of 52 cards, what is the probability it is not a heart?
16. If you pick one card at random from a standard deck of 52 cards, what is the probability it will be an 8?
17. If you pick one card at random from a standard deck of 52 cards, what is the probability it is not a 6?
18. If you pick one card at random from a standard deck of 52 cards, what is the probability it will be a face card?
19. If the probability of a certain event is $\frac{24}{61}$, what is the probability of the event not happening?
20. If the probability of a certain event not happening is $\frac{38}{45}$, what is the probability of the event happening?
21. Find the odds for rolling a die and getting a 1.
22. Find the odds for rolling a die and getting an even number.

23. If you pick one card at random from a standard deck of 52 cards, what are the odds it will be an ace?
24. If you pick one card at random from a standard deck of 52 cards, what are the odds it will be a face card?
25. If the probability of a certain event is $\frac{51}{92}$, what are the odds against the event happening?
26. If the odds against a certain event are 2 to 7, what is the probability of the event occurring?
27. If you pick one card at random from a standard deck of 52 cards, what are the odds it will not be a heart?
28. Find the odds for rolling a die and not getting a 6.
29. A bag contains 3 gold marbles, 6 silver marbles, and 28 black marbles. Someone offers to play this game: You randomly select one marble from the bag. If it is gold, you win \$3. If it is silver, you win \$2. If it is black, you lose \$1. What is your expected value if you play this game?
30. A bag contains 2 gold marbles, 10 silver marbles, and 25 black marbles. Someone offers to play this game: You randomly select one marble from the bag. If it is gold, you win \$3. If it is silver, you win \$2. If it is black, you lose \$1. What is your expected value if you play this game?
31. A friend devises a game that is played by rolling a single six-sided die once. If you roll a 6, he pays you \$3; if you roll a 5, he pays you nothing; if you roll a number less than 5, you pay him \$1. Compute the expected value for this game. Should you play this game?
32. A company estimates that 0.7% of their products will fail after the original warranty period but within 2 years of the purchase, with a replacement cost of \$350. If they offer a 2 year extended warranty for \$48, what is the company's expected value of each warranty sold?
33. An insurance company estimates the probability of an earthquake in the next year to be 0.0013. The average damage done by an earthquake it estimates to be \$60,000. If the company offers earthquake insurance for \$100, what is their expected value of the policy?
34. A company estimates that 0.9% of their products will fail after the original warranty period but within 2 years of the purchase, with a replacement cost of \$500. If they offer a 2 year extended warranty for \$45, what is the company's expected value of each warranty sold?

Chapter 9 – Probability and Counting

Chapter 9 Learning Objectives:

- Be able to calculate “and”/“or” probabilities
- Determine if two or more events are independent
- Determine if two or more events are mutually exclusive
- Use tables and tree diagrams to model possible outcomes in counting problems
- Use permutations and combinations for counting
- Be able to find probabilities using permutations and combinations

Section 9.1 – Independent Events

Section 9.2 – Conditional Probability

Section 9.3 – “Or” Probabilities

Section 9.4 – Basic Counting

Section 9.5 – Permutations

Section 9.6 – Combinations

Section 9.1 – Independent Events

Example 1

Suppose we flipped a coin and rolled a die, and wanted to know the probability of getting a head on the coin and a 6 on the die.

We could list all possible outcomes: {H1,H2,H3,H4,H5,H6,T1,T2,T3,T4,T5,T6}. Notice there are $2 \cdot 6 = 12$ total outcomes. Out of these, only 1 is the desired outcome, so the probability is $P(\text{head}) = \frac{1}{12}$.

The prior example was looking at two **independent events**.

Independent Events

Events A and B are **independent events** if the probability of Event B occurring is the same whether or not Event A occurs.

Example 2

Are these events independent?

- a) A fair coin is tossed two times. The two events are (1) first toss is a head and (2) second toss is a head.
- b) You draw a card from a deck, then draw a second card without replacing the first.

- a) The probability that a head comes up on the second toss is $1/2$ regardless of whether or not a head came up on the first toss, so these events are independent.
- b) The probability of the first card being red is $P(\text{first card is red}) = \frac{26}{52} = \frac{1}{2}$. Since the first card is *not* returned to the deck, the probability of the second card being red is *not the same* as the probability that the first card is red. After drawing the first card, there are only 51 cards remaining in the deck. If the first card was red, then there are only 25 red cards remaining, and the probability that the second card would be red is $P(\text{second card is red}) = \frac{25}{51}$. If the first card was not red, then the probability that the second card would be red is $P(\text{second card is red}) = \frac{26}{51}$. These events are NOT independent.

When two events are independent, the probability of both occurring is just the product of the probabilities of the individual events.

$P(A \text{ and } B)$ for independent events

If events A and B are independent, then the probability of both A and B occurring is

$$P(A \text{ and } B) = P(A) \cdot P(B)$$

where $P(A \text{ and } B)$ is the probability of events A and B both occurring, $P(A)$ is the probability of event A occurring, and $P(B)$ is the probability of event B occurring

If you look back at the coin and die example from earlier, you can see how the number of outcomes of the first event multiplied by the number of outcomes in the second event multiplied to equal the total number of possible outcomes in the combined event.

Example 3

In Alex's drawer she has 10 pairs of socks, 6 of which are white, and 7 tee shirts, 3 of which are white. If she randomly reaches in and pulls out a pair of socks and a tee shirt, what is the probability that both are white?

The probability of choosing a white pair of socks is $\frac{6}{10}$.

The probability of choosing a white tee shirt is $\frac{3}{7}$.

The probability of both being white is $\frac{6}{10} \cdot \frac{3}{7} = \frac{18}{70} = \frac{9}{35}$

You Try 9.1

A couple has two children. Find the probability that both children are girls.

Example 4

You roll two die. Find the probability that the first die lands on an even number, and the second die lands on 5.

Since the outcome of the first die has no effect on the outcome of the second die, the events are independent.

$$P(\text{first die is even}) = \frac{3}{6} = \frac{1}{2}$$

$$P(\text{second die lands on 5}) = \frac{1}{6}$$

$$P(\text{first die is even AND second die lands on 5}) = \frac{1}{2} \times \frac{1}{6} = \frac{1}{12}$$

As a check, it may be helpful to consider all possible outcomes in the experiment of rolling 2 die:

1, 1	1, 2	1, 3	1, 4	1, 5	1, 6
2, 1	2, 2	2, 3	2, 4	2, 5	2, 6
3, 1	3, 2	3, 3	3, 4	3, 5	3, 6
4, 1	4, 2	4, 3	4, 4	4, 5	4, 6
5, 1	5, 2	5, 3	5, 4	5, 5	5, 6
6, 1	6, 2	6, 3	6, 4	6, 5	6, 6

Notice there are 3 outcomes (out of 36 possible outcomes) where the first die is even and the second die lands on 5. We could have found this probability directly as $\frac{3}{36} = \frac{1}{12}$.

Section 9.2 – Conditional Probability

Often it is required to compute the probability of an event given that another event has occurred.

Example 5

What is the probability that two cards drawn at random from a deck of playing cards will both be aces?

It might seem that you could use the formula for the probability of two independent events and simply multiply $\frac{4}{52} \cdot \frac{4}{52} = \frac{1}{169}$. This would be incorrect, however, because the two events are **not independent**. Once the first card is drawn, there are only 51 cards

remaining in the deck. If the first card drawn is an ace, then the probability that the second card is also an ace would be $\frac{3}{51}$ because there would only be three aces left in the deck.

Once the first card chosen is an ace, the probability that the second card chosen is also an ace is called the **conditional probability** of drawing an ace. In this case, the "condition" is that the first card is an ace. Symbolically, we write this as:

$P(\text{ace on second draw} \mid \text{an ace on the first draw})$.

The vertical bar "|" is read as "given," so the above expression is short for "The probability that an ace is drawn on the second draw given that an ace was drawn on the first draw." What is this probability? After an ace is drawn on the first draw, there are 3 aces out of 51 total cards left. This means that the conditional probability of drawing an ace after one ace has already been drawn is $\frac{3}{51} = \frac{1}{17}$.

Thus, the probability of both cards being aces is $\frac{4}{52} \cdot \frac{3}{51} = \frac{12}{2652} = \frac{1}{221}$.

Conditional Probability

The probability that event B occurs, given that event A has happened, is represented as $P(B \mid A)$. This is read as "the probability of B given A "

Example 6

Find the probability that a die rolled shows a 6, given that a flipped coin shows a head.

These are two independent events, so the probability of the die rolling a 6 is $\frac{1}{6}$, regardless of the result of the coin flip.

Example 7

The table below shows the number of survey subjects who have received and not received a speeding ticket in the last year, and the color of their cars. Find the probability that a randomly chosen person:

- Has a speeding ticket *given* they have a red car
- Has a red car *given* they have a speeding ticket

	Speeding ticket	No speeding ticket	Total
Red car	15	135	150
Not red car	45	470	515
Total	60	605	665

a) Since we know the person has a red car, we are only considering the 150 people in the first row of the table. Of those, 15 have a speeding ticket, so

$$P(\text{ticket} \mid \text{red car}) = \frac{15}{150} = \frac{1}{10} = 0.1$$

b) Since we know the person has a speeding ticket, we are only considering the 60 people in the first column of the table. Of those, 15 have a red car, so

$$P(\text{red car} \mid \text{ticket}) = \frac{15}{60} = \frac{1}{4} = 0.25.$$

Notice from the last example that $P(B \mid A)$ is **not** equal to $P(A \mid B)$.

These kinds of conditional probabilities are what insurance companies use to determine your insurance rates. They look at the conditional probability of you having an accident, given your age, your car, your car color, your driving history, etc., and price your policy based on that likelihood.

P(A and B) for dependent events

If Events A and B are **dependent** (not independent), then

$$P(A \text{ and } B) = P(A) \cdot P(B \mid A)$$

Example 8

If you pull 2 cards out of a deck, what is the probability that both are spades?

The probability that the first card is a spade is $\frac{13}{52}$.

The probability that the second card is a spade, given the first was a spade, is $\frac{12}{51}$, since there is one less spade in the deck, and one less total cards.

The probability that both cards are spades is $\frac{13}{52} \cdot \frac{12}{51} = \frac{156}{2652} \approx 0.0588$

You Try 9.2

If you draw 2 cards from a standard deck, what is the probability that both cards are red kings?

Example 9

A home pregnancy test was given to women, then pregnancy was verified through blood tests. The following table shows the home pregnancy test results. Find

- a) $P(\text{not pregnant} \mid \text{positive test result})$
 b) $P(\text{positive test result} \mid \text{not pregnant})$

	Positive test	Negative test	Total
Pregnant	70	4	74
Not Pregnant	5	14	19
Total	75	18	93

- a) Since we know the test result was positive, we're limited to the 75 women in the first column, of which 5 were not pregnant.

$$P(\text{not pregnant} \mid \text{positive test result}) = \frac{5}{75} \approx 0.067.$$

- b) Since we know the woman is not pregnant, we are limited to the 19 women in the second row, of which 5 had a positive test.

$$P(\text{positive test result} \mid \text{not pregnant}) = \frac{5}{19} \approx 0.263$$

The second result is what is usually called a false positive: A positive result when the woman is not actually pregnant.

Section 9.3 – “Or” Probabilities

The previous examples looked at the probability of *both* events occurring. Now we will look at the probability of *either* event occurring.

Example 10

Suppose we flipped a coin and rolled a die, and wanted to know the probability of getting a head on the coin *or* a 6 on the die.

Here, there are still 12 possible outcomes: {H1,H2,H3,H4,H5,H6,T1,T2,T3,T4,T5,T6}

By simply counting, we can see that 7 of the outcomes have a head on the coin *or* a 6 on the die *or* both – we use *or* inclusively here (these 7 outcomes are H1, H2, H3, H4, H5, H6, T6), so the probability is $\frac{7}{12}$. How could we have found this from the individual probabilities?

As we would expect, $\frac{1}{2}$ of these outcomes have a head, and $\frac{1}{6}$ of these outcomes have a 6 on the die. If we add these, $\frac{1}{2} + \frac{1}{6} = \frac{6}{12} + \frac{2}{12} = \frac{8}{12}$, which is not the correct probability. Looking at the outcomes we can see why: the outcome H6 would have been counted twice, since it contains both a head and a 6; the probability of both a head *and* rolling a 6 is $\frac{1}{12}$.

If we subtract out this double count, we have the correct probability: $\frac{8}{12} - \frac{1}{12} = \frac{7}{12}$.

$P(A \text{ or } B)$

The probability of either A or B occurring (or both) is

$$P(A \text{ or } B) = P(A) + P(B) - P(A \text{ and } B)$$

Example 11

Suppose we draw one card from a standard deck. What is the probability that we get a Queen or a King?

There are 4 Queens and 4 Kings in the deck, hence 8 outcomes corresponding to a Queen or King out of 52 possible outcomes. Thus the probability of drawing a Queen or a King is:

$$P(\text{King or Queen}) = \frac{8}{52}$$

Note that in this case, there are no cards that are both a Queen and a King, so

$P(\text{King and Queen}) = \frac{0}{52} = 0$. Using our probability rule, we could have said:

$$P(\text{King or Queen}) = P(\text{King}) + P(\text{Queen}) - P(\text{King and Queen}) = \frac{4}{52} + \frac{4}{52} - 0 = \frac{8}{52}$$

In the last example, the events were **mutually exclusive**, so $P(A \text{ or } B) = P(A) + P(B)$.

Example 12

Suppose we draw one card from a standard deck. What is the probability that we get a red card or a King?

Half the cards are red, so $P(\text{red}) = \frac{26}{52}$

There are four kings, so $P(\text{King}) = \frac{4}{52}$

There are two red kings, so $P(\text{Red and King}) = \frac{2}{52}$

We can then calculate

$$P(\text{Red or King}) = P(\text{Red}) + P(\text{King}) - P(\text{Red and King}) = \frac{26}{52} + \frac{4}{52} - \frac{2}{52} = \frac{28}{52}$$

Example 13

Consider again that we roll two die.

What is the probability that the **sum** of the two die is odd or 4?

Below is a list of all possible outcomes in the experiment of rolling 2 die:

1, 1	1, 2	1, 3	1, 4	1, 5	1, 6
2, 1	2, 2	2, 3	2, 4	2, 5	2, 6
3, 1	3, 2	3, 3	3, 4	3, 5	3, 6
4, 1	4, 2	4, 3	4, 4	4, 5	4, 6
5, 1	5, 2	5, 3	5, 4	5, 5	5, 6
6, 1	6, 2	6, 3	6, 4	6, 5	6, 6

Note: The table gives the values of each die, not the sum of the two die.

Since it is not possible for the sum to be *both* odd and 4, these events are mutually exclusive.

$$P(\text{sum is odd}) = \frac{18}{36} = \frac{1}{2}$$

$$P(\text{sum is 4}) = \frac{3}{36} = \frac{1}{12}$$

$$P(\text{sum is odd and 4}) = \frac{0}{36} = 0$$

$$\begin{aligned} P(\text{sum is odd or 4}) &= P(\text{sum is odd}) + P(\text{sum is 4}) - P(\text{sum is odd and 4}) \\ &= \frac{18}{36} + \frac{3}{36} - \frac{0}{36} = \frac{21}{36} \\ &= \frac{7}{12} \end{aligned}$$

You Try 9.3

Consider again that we roll two die. What is the probability that the sum of the two die is odd or one of the die is a 1?

Example 14

The table below shows the number of survey subjects who have received and not received a speeding ticket in the last year, and the color of their car. Find the probability that a randomly chosen person:

a) Has a red car *and* got a speeding ticket

b) Has a red car *or* got a speeding ticket.

	Speeding ticket	No speeding ticket	Total
Red car	15	135	150
Not red car	45	470	515
Total	60	605	665

a) We can see that 15 people of the 665 surveyed had both a red car and got a speeding ticket, so the probability is

$$P(\text{red car and speeding ticket}) = \frac{15}{665} \approx 0.0226.$$

Notice that having a red car and getting a speeding ticket are not independent events, so the probability of both of them occurring is not simply the product of probabilities of each one occurring.

b) We could answer this question by simply adding up the numbers: 15 people with red cars and speeding tickets + 135 with red cars but no ticket + 45 with a ticket but no red car = 195 people. So the probability is

$$P(\text{red car or speeding ticket}) = \frac{195}{665}.$$

We also could have found this probability by:

$$P(\text{red car}) + P(\text{speeding ticket}) - P(\text{red car and speeding ticket})$$

$$P(\text{red car or speeding ticket}) = \frac{150}{665} + \frac{60}{665} - \frac{15}{665} = \frac{195}{665} \approx 0.2932.$$

Section 9.4 – Basic Counting

Counting? You already know how to count or you wouldn't be taking a college-level math class, right? Well yes, but what we'll really be investigating here are ways of counting *efficiently*. When we get to the probability situations a bit later in this chapter we will need to count some *very* large numbers, like the number of possible winning lottery tickets. One way to do this would be to write down every possible set of numbers that might show up on a lottery ticket, but believe me: you don't want to do this. We will start, however, with some more reasonable sorts of counting problems in order to develop the ideas that we will soon need.

Example 15

Suppose at a particular restaurant you have three choices for an appetizer (soup, salad or breadsticks) and five choices for a main course (hamburger, sandwich, quiche, fajita or pizza). If you are allowed to choose exactly one item from each category for your meal, how many different meal options do you have?

Solution 1: One way to solve this problem would be to systematically list each possible meal:

soup + hamburger	soup + sandwich	soup + quiche
soup + fajita	soup + pizza	salad + hamburger
salad + sandwich	salad + quiche	salad + fajita
salad + pizza	breadsticks + hamburger	breadsticks + sandwich
breadsticks + quiche	breadsticks + fajita	breadsticks + pizza

Assuming that we did this systematically and that we neither missed any possibilities nor listed any possibility more than once, the answer would be 15. Thus you could go to the restaurant 15 nights in a row and have a different meal each night.

Solution 2: Another way to solve this problem would be to list all the possibilities in a table:

	hamburger	sandwich	quiche	fajita	pizza
soup	soup+burger				
salad	salad+burger				
bread	<i>etc.</i>				

In each of the cells in the table we could list the corresponding meal: soup + hamburger in the upper left corner, salad + hamburger below it, etc. But if we didn't really care *what* the possible meals are, only *how many* possible meals there are, we could just count the number of cells and arrive at an answer of 15, which matches our answer from the first solution. (It's always good when you solve a problem two different ways and get the same answer!)

Solution 3: We already have two perfectly good solutions. Why do we need a third? The first method was not very systematic, and we might easily have made an omission. The second method was better, but suppose that in addition to the appetizer and the main course we further complicated the problem by adding desserts to the menu: we've used the rows of the table for the appetizers and the columns for the main courses—where will the desserts go? We would need a third dimension, and since drawing 3-D tables on a 2-D page or computer screen isn't terribly easy, we need a better way in case we have three categories to choose from instead of just two.

So, back to the problem in the example. What else can we do? Let's draw a **tree diagram**:

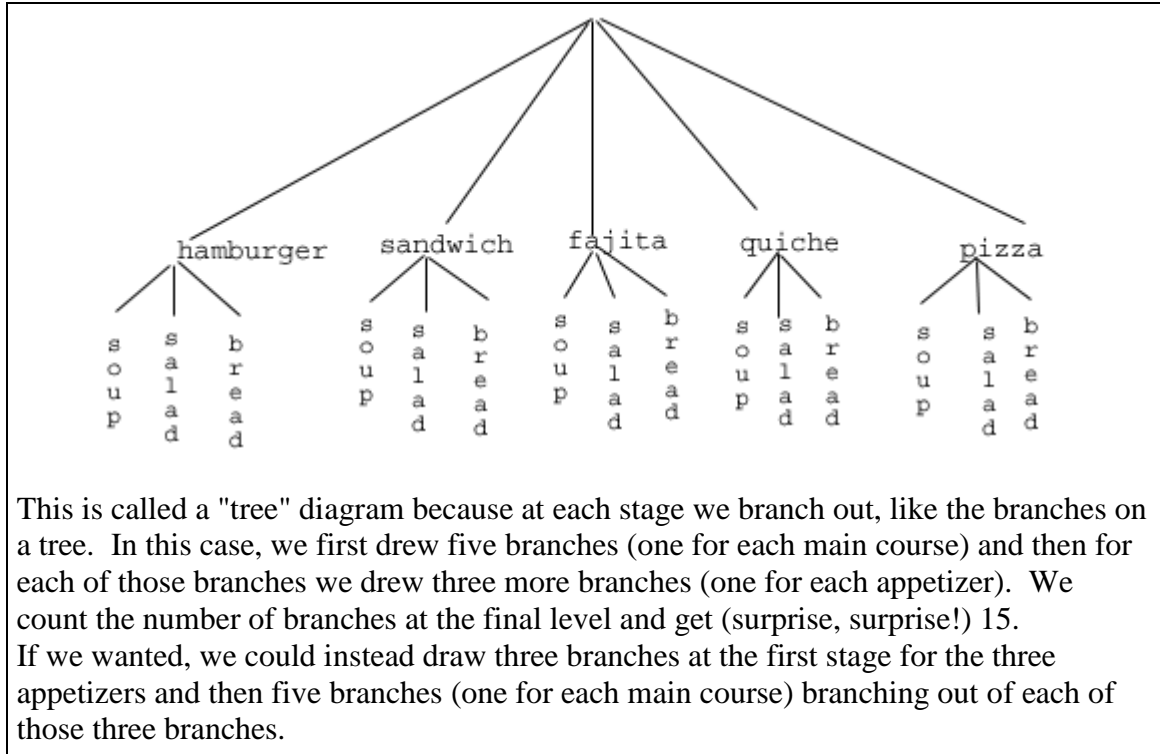

OK, so now we know how to count possibilities using tables and tree diagrams. These methods will continue to be useful in certain cases, but imagine a game where you have two decks of cards (with 52 cards in each deck) and you select one card from each deck. Would you really want to draw a table or tree diagram to determine the number of outcomes of this game?

Let's go back to the previous example that involved selecting a meal from three appetizers and five main courses, and look at the second solution that used a table. Notice that one way to count the number of possible meals is simply to number each of the appropriate cells in the table, as we have done above. But another way to count the number of cells in the table would be multiply the number of rows (3) by the number of columns (5) to get 15. Notice that we could have arrived at the same result without making a table at all by simply multiplying the number of choices for the appetizer (3) by the number of choices for the main course (5). We generalize this technique as the *basic counting rule*:

Basic Counting Rule

If we are asked to choose one item from each of two separate categories where there are m items in the first category and n items in the second category, then the total number of available choices is $m \cdot n$.

This is sometimes called the multiplication rule for probabilities.

Example 16

There are 21 novels and 18 volumes of poetry on a reading list for a college English course. How many different ways can a student select one novel and one volume of poetry to read during the quarter?

There are 21 choices from the first category and 18 for the second, so there are $21 \cdot 18 = 378$ possibilities.

The Basic Counting Rule can be extended when there are more than two categories by applying it repeatedly, as we see in the next example.

Example 17

Suppose at a particular restaurant you have three choices for an appetizer (soup, salad or breadsticks), five choices for a main course (hamburger, sandwich, quiche, fajita or pasta) and two choices for dessert (pie or ice cream). If you are allowed to choose exactly one item from each category for your meal, how many different meal options do you have?

There are 3 choices for an appetizer, 5 for the main course and 2 for dessert, so there are $3 \cdot 5 \cdot 2 = 30$ possibilities.

You Try 9.4

You are making your schedule for next semester. You have 5 choices for your math class, 8 choices for your English class, 3 choices for your communications class, and 4 choices for your elective. How many different schedules are possible?

Example 18

A quiz consists of 3 true-or-false questions. In how many ways can a student answer the quiz?

There are 3 questions. Each question has 2 possible answers (true or false), so the quiz may be answered in $2 \cdot 2 \cdot 2 = 8$ different ways. Recall that another way to write $2 \cdot 2 \cdot 2$ is 2^3 , which is much more compact.

Section 9.5 – Permutations

We will now develop an even faster way to solve some of the problems we have already learned to solve by other means. Let's start with a couple examples.

Example 19

How many different ways can the letters of the word MATH be rearranged to form a four-letter code word?

This problem is a bit different. Instead of choosing one item from each of several different categories, we are repeatedly choosing items from the *same* category (the category is: the letters of the word MATH) and each time we choose an item we *do not replace* it, so there is one fewer choice at the next stage: we have 4 choices for the first letter (say we choose A), then 3 choices for the second (M, T and H; say we choose H), then 2 choices for the next letter (M and T; say we choose M) and only one choice at the last stage (T). Thus there are $4 \cdot 3 \cdot 2 \cdot 1 = 24$ ways to spell a code word with the letters MATH.

In this example, we needed to calculate $n \cdot (n - 1) \cdot (n - 2) \cdots 3 \cdot 2 \cdot 1$. This calculation shows up often in mathematics, and is called the **factorial**, and is notated $n!$

Factorial

$$n! = n \cdot (n - 1) \cdot (n - 2) \cdots 3 \cdot 2 \cdot 1$$

Example 20

How many ways can five different door prizes be distributed among five people?

There are 5 choices of prize for the first person, 4 choices for the second, and so on. The number of ways the prizes can be distributed will be $5! = 5 \cdot 4 \cdot 3 \cdot 2 \cdot 1 = 120$ ways.

You Try 9.5A

A little league baseball team has 12 players. How many different batting orders of the 12 players are possible?

Now we will consider some slightly different examples.

Example 21

A charity benefit is attended by 25 people and three gift certificates are given away as door prizes: one gift certificate is in the amount of \$100, the second is worth \$25 and the third is worth \$10. Assuming that no person receives more than one prize, how many different ways can the three gift certificates be awarded?

Using the Basic Counting Rule, there are 25 choices for the person who receives the \$100 certificate, 24 remaining choices for the \$25 certificate and 23 choices for the \$10 certificate, so there are $25 \cdot 24 \cdot 23 = 13,800$ ways in which the prizes can be awarded.

Example 22
Eight sprinters have made it to the Olympic finals in the 100-meter race. In how many different ways can the gold, silver and bronze medals be awarded?
Using the Basic Counting Rule, there are 8 choices for the gold medal winner, 7 remaining choices for the silver, and 6 for the bronze, so there are $8 \cdot 7 \cdot 6 = 336$ ways the three medals can be awarded to the 8 runners.

Note that in these preceding examples, the gift certificates and the Olympic medals were awarded *without replacement*; that is, once we have chosen a winner of the first door prize or the gold medal, they are not eligible for the other prizes. Thus, at each succeeding stage of the solution there is one fewer choice (25, then 24, then 23 in the first example; 8, then 7, then 6 in the second). Contrast this with the situation of a multiple choice test, where there might be five possible answers — A, B, C, D or E — for each question on the test.

Note also that *the order of selection was important* in each example: for the three door prizes, being chosen first means that you receive substantially more money; in the Olympics example, coming in first means that you get the gold medal instead of the silver or bronze. In each case, if we had chosen the same three people in a different order there might have been a different person who received the \$100 prize, or a different gold medalist. (Contrast this with the situation where we might draw three names out of a hat to each receive a \$10 gift certificate; in this case the order of selection is *not* important since each of the three people receive the same prize. Situations where the order is *not* important will be discussed in the next section.)

We can generalize the situation in the two examples above to any problem *without replacement* where the *order of selection is important*. If we are arranging in order r items out of n possibilities (instead of 3 out of 25 or 3 out of 8 as in the previous examples), the number of possible arrangements will be given by

$$n \cdot (n - 1) \cdot (n - 2) \cdots (n - r + 1)$$

If you don't see why $(n - r + 1)$ is the right number to use for the last factor, just think back to the first example in this section, where we calculated $25 \cdot 24 \cdot 23$ to get 13,800. In this case $n = 25$ and $r = 3$, so $n - r + 1 = 25 - 3 + 1 = 23$, which is exactly the right number for the final factor.

Now, why would we want to use this complicated formula when it's actually easier to use the Basic Counting Rule, as we did in the first two examples? Well, we won't actually use this formula all that often, we only developed it so that we could attach a special notation and a special definition to this situation where we are choosing r items out of n possibilities *without replacement* and where the *order of selection is important*. In this situation we write:

Permutations

$${}_n P_r = n \cdot (n - 1) \cdot (n - 2) \cdots (n - r + 1)$$

We say that there are ${}_n P_r$ **permutations** of size r that may be selected from among n choices *without replacement* when *order matters*.

It turns out that we can express this result more simply using factorials.

$${}_n P_r = \frac{n!}{(n - r)!}$$

In practicality, we usually use technology rather than factorials or repeated multiplication to compute permutations.

Example 23

I have nine paintings and have room to display only four of them at a time on my wall. How many different ways could I do this?

Since we are choosing 4 paintings out of 9 *without replacement* where the *order of selection is important* there are ${}_9 P_4 = 9 \cdot 8 \cdot 7 \cdot 6 = 3,024$ permutations.

To enter ${}_9 P_4$ in your graphing calculator, type 9, then hit the MATH key, scroll over to PRB, select option “2:nPr” by hitting enter. Your main screen should now show “9 nPr” and have a blinking cursor. Type 4, so that your calculator shows “9 nPr 4”. Hit enter and you will get the answer 3,024.

Example 24

How many ways can a four-person executive committee (president, vice-president, secretary, treasurer) be selected from a 16-member board of directors of a non-profit organization?

We want to choose 4 people out of 16 without replacement and where the order of selection is important. So the answer is ${}_{16} P_4 = 16 \cdot 15 \cdot 14 \cdot 13 = 43,680$.

You Try 9.5B

How many 5 character passwords can be made using the letters A through Z

- if repeats are allowed
- if no repeats are allowed

Up to this point we have been using permutations to help us **count**, but we can also use permutations to help us answer more complex **probability** questions. In the following examples, we will use permutations to find probabilities of certain events.

Example 25

A 4 digit PIN number is selected. What is the probability that there are no repeated digits?

There are 10 possible values for each digit of the PIN (namely: 0, 1, 2, 3, 4, 5, 6, 7, 8, 9), so there are $10 \cdot 10 \cdot 10 \cdot 10 = 10^4 = 10000$ total possible PIN numbers.

To have no repeated digits, all four digits would have to be different, which is selecting without replacement. We could either compute $10 \cdot 9 \cdot 8 \cdot 7$, or notice that this is the same as the permutation ${}_{10}P_4 = 5040$.

The probability of no repeated digits is the number of 4 digit PIN numbers with no repeated digits divided by the total number of 4 digit PIN numbers. This probability is

$$\frac{{}_{10}P_4}{10^4} = \frac{5040}{10000} = 0.504$$

Birthday Problem

Let's take a pause to consider a famous problem in probability theory:

Suppose you have a room full of 30 people. What is the probability that there is at least one shared birthday?

Take a guess at the answer to the above problem. Was your guess fairly low, like around 10%? That seems to be the intuitive answer (30/365, perhaps?). Let's see if we should listen to our intuition. Let's start with a simpler problem, however.

Example 26

Suppose three people are in a room. What is the probability that there is at least one shared birthday among these three people?

There are a lot of ways there could be at least one shared birthday. Fortunately there is an easier way. We ask ourselves “What is the alternative to having at least one shared birthday?” In this case, the alternative is that there are **no** shared birthdays. In other words, the alternative to “at least one” is having **none**. In other words, since this is a complementary event,

$$P(\text{at least one}) = 1 - P(\text{none})$$

We will start, then, by computing the probability that there is no shared birthday. Let's imagine that you are one of these three people. Your birthday can be anything without conflict, so there are 365 choices out of 365 for your birthday. What is the probability that the second person does not share your birthday? There are 365 days in the year (let's ignore leap years) and removing your birthday from contention, there are 364 choices that will guarantee that you do not share a birthday with this person, so the

probability that the second person does not share your birthday is $364/365$. Now we move to the third person. What is the probability that this third person does not have the same birthday as either you or the second person? There are 363 days that will not duplicate your birthday or the second person's, so the probability that the third person does not share a birthday with the first two is $363/365$.

We want the second person not to share a birthday with you *and* the third person not to share a birthday with the first two people, so we use the multiplication rule:

$$P(\text{no shared birthday}) = \frac{365}{365} \cdot \frac{364}{365} \cdot \frac{363}{365} \approx 0.9918$$

and then subtract from 1 to get

$$P(\text{shared birthday}) = 1 - P(\text{no shared birthday}) = 1 - 0.9918 = 0.0082.$$

This is a pretty small number, so maybe it makes sense that the answer to our original problem will be small. Let's make our group a bit bigger.

Example 27

Suppose five people are in a room. What is the probability that there is at least one shared birthday among these five people?

Continuing the pattern of the previous example, the answer should be

$$P(\text{shared birthday}) = 1 - \frac{365}{365} \cdot \frac{364}{365} \cdot \frac{363}{365} \cdot \frac{362}{365} \cdot \frac{361}{365} \approx 0.0271$$

Note that we could rewrite this more compactly as

$$P(\text{shared birthday}) = 1 - \frac{{}^{365}P_5}{365^5} \approx 0.0271$$

which makes it a bit easier to type into a calculator or computer, and which suggests a nice formula as we continue to expand the population of our group.

Example 28

Suppose 30 people are in a room. What is the probability that there is at least one shared birthday among these 30 people?

Here we can calculate

$$P(\text{shared birthday}) = 1 - \frac{{}^{365}P_{30}}{365^{30}} \approx 0.706$$

which gives us the surprising result that when you are in a room with 30 people there is a 70% chance that there will be at least one shared birthday!

If you like to bet, and if you can convince 30 people to reveal their birthdays, you might be able to win some money by betting a friend that there will be at least two people with the same birthday in the room anytime you are in a room of 30 or more people. (Of course, you would need to make sure your friend hasn't studied probability!) You wouldn't be guaranteed to win, but you should win more than half the time.

You Try 9.5C

Suppose 10 people are in a room. What is the probability that there is at least one shared birthday among these 10 people?

Section 9.6 Combinations

In the previous section we considered the situation where we chose r items out of n possibilities *without replacement* and where the *order of selection was important*. We now consider a similar situation in which the order of selection is *not* important.

Example 29

A charity benefit is attended by 25 people at which three \$50 gift certificates are given away as door prizes. Assuming no person receives more than one prize, how many different ways can the gift certificates be awarded?

Using the Basic Counting Rule, there are 25 choices for the first person, 24 remaining choices for the second person and 23 for the third, so there are $25 \cdot 24 \cdot 23 = 13,800$ ways to choose three people. Suppose for a moment that Abe is chosen first, Bea second and Cindy third; this is one of the 13,800 possible outcomes. Another way to award the prizes would be to choose Abe first, Cindy second and Bea third; this is another of the 13,800 possible outcomes. But either way Abe, Bea and Cindy each get \$50, so it doesn't really matter the order in which we select them. In how many different orders can Abe, Bea and Cindy be selected? It turns out there are 6:

ABC ACB BAC BCA CAB CBA

How can we be sure that we have counted them all? We are really just choosing 3 people out of 3, so there are $3 \cdot 2 \cdot 1 = 6$ ways to do this; we didn't really need to list them all, we can just use permutations!

So, out of the 13,800 ways to select 3 people out of 25, six of them involve Abe, Bea and Cindy. The same argument works for any other group of three people (say Abe, Bea and David or Frank, Gloria and Hildy) so each three-person group is counted *six times*. Thus the 13,800 figure is six times too big. The number of distinct three-person groups will be $13,800/6 = 2300$.

We can generalize the situation in this example above to any problem of choosing a collection of items *without replacement* where the *order of selection is not important*. If we are choosing r items out of n possibilities (instead of 3 out of 25 as in the previous examples), the number of possible choices will be given by $\frac{{}_n P_r}{{}_r P_r}$, and we could use this

formula for computation. However this situation arises so frequently that we attach a special notation and a special definition to this situation where we are choosing r items out of n possibilities *without replacement* where the *order of selection is not important*.

Combinations

$${}_n C_r = \frac{{}_n P_r}{{}_r P_r}$$

We say that there are ${}_n C_r$ **combinations** of size r that may be selected from among n choices *without replacement* where *order doesn't matter*.

We can also write the combinations formula in terms of factorials:

$${}_n C_r = \frac{n!}{(n-r)!r!}$$

Example 30

A group of four students is to be chosen from a 35-member class to represent the class on the student council. How many ways can this be done?

Since we are choosing 4 people out of 35 *without replacement* where the *order of selection is not important* there are ${}_{35} C_4 = \frac{35 \cdot 34 \cdot 33 \cdot 32}{4 \cdot 3 \cdot 2 \cdot 1} = 52,360$ combinations.

Your graphing calculator will also find combinations. For this example, type 35, select MATH, PRB, nCr. Your main screen should show “35 nCr” with a blinking cursor. Type 4. Your main screen should now show “35 nCr 4”. Hit “enter” to get the answer 52,360.

You Try 9.6A

The United States Senate Appropriations Committee consists of 29 members; the Defense Subcommittee of the Appropriations Committee consists of 19 members. Disregarding party affiliation or any special seats on the Subcommittee, how many different 19-member subcommittees may be chosen from among the 29 Senators on the Appropriations Committee?

In the preceding You Try problem we assumed that the 19 members of the Defense Subcommittee were chosen without regard to party affiliation. In reality this would never happen: if Republicans are in the majority they would never let a majority of Democrats sit on (and thus control) any subcommittee. (The same of course would be true if the Democrats were in control.) So let's consider the problem again, in a slightly more complicated form:

Example 31

The United States Senate Appropriations Committee consists of 29 members, 15 Republicans and 14 Democrats. The Defense Subcommittee consists of 19 members, 10 Republicans and 9 Democrats. How many different ways can the members of the Defense Subcommittee be chosen from among the 29 Senators on the Appropriations Committee?

In this case we need to choose 10 of the 15 Republicans and 9 of the 14 Democrats. There are ${}_{15}C_{10} = 3003$ ways to choose the 10 Republicans and ${}_{14}C_9 = 2002$ ways to choose the 9 Democrats. But now what? How do we finish the problem?

Suppose we listed all of the possible 10-member Republican groups on 3003 slips of red paper and all of the possible 9-member Democratic groups on 2002 slips of blue paper. How many ways can we choose one red slip and one blue slip? This is a job for the Basic Counting Rule! We are simply making one choice from the first category and one choice from the second category, just like in the restaurant menu problems from earlier.

There must be $3003 \cdot 2002 = 6,012,006$ possible ways of selecting the members of the Defense Subcommittee.

Just as we did with permutations, we can now use combinations to move beyond **counting** and help us answer more complex **probability** questions.

Example 32

In a certain state's lottery, 48 balls numbered 1 through 48 are placed in a machine and six of them are drawn at random. If the six numbers drawn match the numbers that a player had chosen, the player wins \$1,000,000. In this lottery, the order the numbers are drawn in doesn't matter. Compute the probability that you win the million-dollar prize if you purchase a single lottery ticket.

In order to compute the probability, we need to count the total number of ways six numbers can be drawn, and the number of ways the six numbers on the player's ticket could match the six numbers drawn from the machine. Since there is no stipulation that the numbers be in any particular order, the number of possible outcomes of the lottery drawing is ${}_{48}C_6 = 12,271,512$. Of these possible outcomes, only one would match all six numbers on the player's ticket, so the probability of winning the grand prize is:

$$\frac{{}_6C_6}{{}_{48}C_6} = \frac{1}{12271512} \approx 0.0000000815$$

Example 33

In the state lottery from the previous example, if five of the six numbers drawn match the numbers that a player has chosen, the player wins a second prize of \$1,000. Compute the probability that you win the second prize if you purchase a single lottery ticket.

As above, the number of possible outcomes of the lottery drawing is ${}_{48}C_6 = 12,271,512$. In order to win the second prize, five of the six numbers on the ticket must match five of the six winning numbers; in other words, we must have chosen five of the six winning numbers and one of the 42 losing numbers. The number of ways to choose 5 out of the 6 winning numbers is given by ${}_6C_5 = 6$ and the number of ways to choose 1 out of the 42 losing numbers is given by ${}_{42}C_1 = 42$. Thus the number of favorable outcomes is then given by the Basic Counting Rule: ${}_6C_5 \cdot {}_{42}C_1 = 6 \cdot 42 = 252$. So the probability of winning the second prize is.

$$\frac{({}_6C_5)({}_{42}C_1)}{{}_{48}C_6} = \frac{252}{12271512} \approx 0.0000205$$

Example 34

Compute the probability of randomly drawing five cards from a deck and getting exactly one Ace.

In many card games (such as poker) the order in which the cards are drawn is not important (since the player may rearrange the cards in his hand any way he chooses); in the problems that follow, we will assume that this is the case unless otherwise stated. Thus we use combinations to compute the possible number of 5-card hands, ${}_{52}C_5$. This number will go in the denominator of our probability formula, since it is the number of possible outcomes.

For the numerator, we need the number of ways to draw one Ace and four other cards (none of them Aces) from the deck. Since there are four Aces and we want exactly one of them, there will be ${}_4C_1$ ways to select one Ace; since there are 48 non-Aces and we want 4 of them, there will be ${}_{48}C_4$ ways to select the four non-Aces. Now we use the Basic Counting Rule to calculate that there will be ${}_4C_1 \cdot {}_{48}C_4$ ways to choose one ace and four non-Aces.

Putting this all together, we have

$$P(\text{one Ace}) = \frac{({}_4C_1)({}_{48}C_4)}{{}_{52}C_5} = \frac{778320}{2598960} \approx 0.299$$

Example 35

Compute the probability of randomly drawing five cards from a deck and getting exactly two Aces.

The solution is similar to the previous example, except now we are choosing 2 Aces out of 4 and 3 non-Aces out of 48; the denominator remains the same:

$$P(\text{two Aces}) = \frac{{}_4C_2({}_{48}C_3)}{{}_{52}C_5} = \frac{103776}{2598960} \approx 0.0399$$

It is useful to note that these card problems are remarkably similar to the lottery problems discussed earlier.

You Try 9.6B

Compute the probability of randomly drawing five cards from a deck of cards and getting three Aces and two Kings.

Chapter 9 – Answers to You Try Problems

9.1. $1/4$

9.2. 0.00075

9.3. $23/36$

9.4. 480 different schedules are possible

9.5A. 479,001,600

9.5B. a. $26^5 = 11,881,376$ b. ${}_{26}P_5 = 7,893,600$

9.5C. 0.1169

9.6A. 20,030,010

9.6B. 0.000009234

Chapter 9 – Practice Problems

1. A six-sided die is rolled twice. What is the probability of showing a 2 on the first roll and an odd number on the second roll?
2. A six-sided die is rolled three times. What is the probability of showing an even number on all three rolls?
3. A six-sided die is rolled twice. What is the probability of showing a 6 on both rolls?
4. A fair coin is flipped twice. What is the probability of showing heads on both flips?
5. A die is rolled twice. What is the probability of showing a 5 on the first roll and an even number on the second roll?
6. A couple has three children. What is the probability that all three are girls?
7. Suppose that 21% of people own dogs. If you pick two people at random, what is the probability that they both own a dog?
8. In your drawer you have 5 pairs of socks, 4 of which are white, and 11 tee shirts, 2 of which are white. If you randomly reach in and pull out a pair of socks and a tee shirt, what is the probability that both are white?
9. Bert and Ernie each have a well-shuffled standard deck of 52 cards. They each draw one card from their own deck. Compute the probability that:
 - a. Bert and Ernie both draw an Ace.
 - b. Bert draws an Ace but Ernie does not.
 - c. Neither Bert nor Ernie draws an Ace.
 - d. Bert and Ernie both draw a heart.
 - e. Bert gets a card that is not a Jack and Ernie draws a card that is not a heart.
10. Bert has a well-shuffled standard deck of 52 cards, from which he draws one card; Ernie has a 12-sided die, which he rolls at the same time Bert draws a card. Compute the probability that:
 - a. Bert gets a Jack and Ernie rolls a five.
 - b. Bert gets a heart and Ernie rolls a number less than six.
 - c. Bert gets a face card (Jack, Queen or King) and Ernie rolls an even number.
 - d. Bert gets a red card and Ernie rolls a fifteen.
 - e. Bert gets a card that is not a Jack and Ernie rolls a number that is not twelve.

11. A jar contains 5 red marbles numbered 1 to 5 and 8 blue marbles numbered 1 to 8. A marble is drawn at random from the jar. Find the probability the marble is
 - a. Even-numbered given that the marble is red.
 - b. Red given that the marble is even-numbered.

12. A jar contains 4 red marbles numbered 1 to 4 and 8 blue marbles numbered 1 to 8. A marble is drawn at random from the jar. Find the probability the marble is
 - a. Odd-numbered given that the marble is blue.
 - b. Blue given that the marble is odd-numbered.

13. Compute the probability of flipping a coin and getting heads, given that the previous flip was tails.

14. Find the probability of rolling a “1” on a fair die, given that the last 3 rolls were all ones.

15. Suppose a math class contains 25 students, 14 females (three of whom speak French) and 11 males (two of whom speak French).
 - a. Compute the probability that a randomly selected student speaks French, given that the student is female.

 - b. Compute the probability that a randomly selected student is male, given that the student speaks French.

16. A test was given to a group of students. The grades and gender are summarized below.

	A	B	C	Total
Male	10	12	2	24
Female	16	6	9	31
Total	26	18	11	55

Suppose a student is chosen at random:

- a. Find the probability that the student was male given they earned an A.
- b. Find the probability that the student was male given they earned a C.
- c. Find the probability that the student was female given they earned a B.

17. A test was given to a group of students. The grades and gender are summarized below.

	A	B	C	Total
Male	7	6	4	17
Female	9	2	10	21
Total	16	8	14	38

- Suppose a student is chosen at random:
- Find the probability that the student earned a B given they are male.
 - Find the probability that the student earned a B given they are female.
 - Find the probability that the student earned a C given they are male.
18. A certain virus infects one in every 400 people. A test used to detect the virus in a person is positive 90% of the time if the person has the virus and 10% of the time if the person does not have the virus. Let A be the event "the person is infected" and B be the event "the person tests positive".
- Find the probability that a person has the virus given that they have tested positive, i.e. find $P(A | B)$.
 - Find the probability that a person does not have the virus given that they test negative, i.e. find $P(\text{not } A | \text{not } B)$.
19. A certain virus infects one in every 2000 people. A test used to detect the virus in a person is positive 96% of the time if the person has the virus and 4% of the time if the person does not have the virus. Let A be the event "the person is infected" and B be the event "the person tests positive".
- Find the probability that a person has the virus given that they have tested positive, i.e. find $P(A | B)$.
 - Find the probability that a person does not have the virus given that they test negative, i.e. find $P(\text{not } A | \text{not } B)$.
20. Two cards are drawn from a standard deck of cards. What is the probability of drawing a King and then drawing a Queen.
21. Two cards are drawn from a standard deck of cards. What is the probability of both cards being red?
22. Two cards are drawn from a standard deck of cards. What is the probability of drawing a Jack and then drawing an Ace?
23. Five cards are drawn from a standard deck of cards. What is the probability of all cards being black?

24. Tony buys a bag of cookies that contains 4 chocolate chip cookies, 9 peanut butter cookies, 7 sugar cookies and 8 oatmeal cookies. What is the probability that Tony reaches in the bag and randomly selects a peanut butter cookie from the bag, eats it, then reaches back in the bag and randomly selects a sugar cookie?
25. Suppose a jar contains 17 red marbles and 32 blue marbles. If you reach in the jar and pull out 2 marbles at random, find the probability that both are red.
26. Suppose you write each letter of the alphabet on a different slip of paper and put the slips into a hat. If you pull out two slips at random, find the probability that both are vowels.
27. A math class consists of 25 students, 14 female and 11 male. Two students are selected at random to participate in a probability experiment. Compute the probability that
- a male is selected, then a female.
 - a female is selected, then a male.
 - two males are selected.
 - two females are selected.
 - no males are selected.
28. A math class consists of 25 students, 14 female and 11 male. Three students are selected at random to participate in a probability experiment. Compute the probability that
- a male is selected, then two females.
 - a female is selected, then two males.
 - two females are selected, then one male.
 - three males are selected.
 - three females are selected.
29. A test was given to a group of students. The grades and gender are summarized below.

	A	B	C	Total
Male	8	18	13	39
Female	10	4	12	26
Total	18	22	25	65

Suppose a student is chosen at random:

- Find the probability that the student is female and earned an A.
- Find the probability that the student is male and earned an A.
- Find the probability that the student is male or earned a C.
- Find the probability that the student is female or earned a B.

30. The table below shows the number of credit cards owned by a group of individuals.

	Zero	One	Two or more	Total
Male	9	5	19	33
Female	18	10	20	48
Total	27	15	39	81

- Suppose a person is chosen at random:
- Find the probability that the person is male and has two or more credit cards.
 - Find the probability that the person is female and has one credit card.
 - Find the probability that the person is male or has no credit cards.
 - Find the probability that the person is female or has two or more credit cards.
31. Suppose we draw one card from a standard deck. What is the probability of drawing the King of hearts or a Queen?
32. Suppose you roll a six-sided die. What is the probability that you roll an even number or a five?
33. Suppose we draw one card from a standard deck. What is the probability of drawing a King or a heart?
34. Suppose we draw one card from a standard deck. What is the probability of drawing a face card or a diamond?
35. Suppose we draw one card from a standard deck. What is the probability of drawing a Jack or a black card?
36. Two six-sided dice are rolled. What is the probability of getting a sum of either 11 or 12?
37. A jar contains 6 red marbles numbered 1 to 6 and 8 blue marbles numbered 1 to 8. A marble is drawn at random from the jar. Find the probability the marble is red or odd-numbered.
38. A jar contains 4 red marbles numbered 1 to 4 and 10 blue marbles numbered 1 to 10. A marble is drawn at random from the jar. Find the probability the marble is blue or even-numbered.
39. A jar contains 4 red marbles numbered 1 to 4 and 12 blue marbles numbered 1 to 12. A marble is drawn at random from the jar. Find the probability of the given event.
- The marble is red or odd-numbered
 - The marble is blue and even-numbered

40. Given the following information, determine $P(A \text{ or } B)$.
- $$P(A) = 0.56$$
- $$P(B) = 0.53$$
- $$P(A \text{ and } B) = 0.42$$
- $$P(B|A) = 0.3$$
41. Given the following information, determine $P(A \text{ or } B)$.
- $$P(A) = 0.76$$
- $$P(B) = 0.3$$
- $$P(A \text{ and } B) = 0.28$$
- $$P(B | A) = 0.2$$
42. A boy owns 5 pairs of pants, 4 shirts, 1 tie, and 3 jackets. How many different outfits can he wear to school if he must wear one of each item?
43. A boy owns 2 pairs of pants, 3 shirts, 8 ties, and 2 jackets. How many different outfits can he wear to school if he must wear one of each item?
44. Bailey has 5 skirts, 9 blouses, and 10 pairs of shoes. How many different skirt-blouse-shoe outfits can she wear?
45. At a restaurant you can choose from 3 appetizers, 8 entrees, and 2 desserts. How many different three-course meals can you have?
46. A pizza place has pizzas in 4 different sizes, with 12 different flavors for the crust, and 10 different toppings. How many one-topping pizzas can be ordered?
47. Standard automobile license plates in a country display 1 numbers, followed by 2 letters, followed by 4 numbers. How many different standard plates are possible in this system? (Assume repetitions of letters and numbers are allowed.)
48. All of the license plates in a particular state feature three letters followed by three digits (e.g. ABC 123). How many different license plate numbers are available to the state's Department of Motor Vehicles? (Assume repetitions of letters and numbers are allowed.)
49. A true-false test contains 13 questions. In how many different ways can this test be completed? (Assume we don't care about our scores.)
50. A computer password must be eight characters long. How many passwords are possible if only the 26 lowercase letters of the alphabet are allowed? (Assume repetitions of letters are allowed.)
51. A computer password must be ten characters long. How many passwords are possible if numbers, 26 lowercase letters, and 26 uppercase letters are allowed? (Assume repetitions of numbers and letters are allowed).

52. A gate has a standard keypad with the digits 0 through 9. How many possible code combinations are there if the code is 5 digits long. (Assume repetitions of numbers are allowed.)
53. You are taking a quiz that has 11 multiple-choice questions. If each question has 4 possible answers, how many different ways are there to answer the test?
54. How many three-letter "words" can be made from 4 letters "FGHI" if
- repetition of letters is allowed
 - repetition of letters is not allowed
55. How many four-letter "words" can be made from 6 letters "AEBWDP" if
- repetition of letters is allowed
 - repetition of letters is not allowed
56. How many three-letter "words" can be made from 10 letters "FGHIJKLMNO" if
- repetition of letters is allowed
 - repetition of letters is not allowed
57. A pianist plans to play 4 pieces at a recital. In how many ways can she arrange these pieces in the program?
58. In how many ways can first, second, and third prizes be awarded in a contest with 210 contestants? (Assume a contestant can only win one prize.)
59. Seven Olympic sprinters are eligible to compete in the 4 x 100 meter relay race for the USA Olympic team. How many four-person relay teams can be selected from among the seven athletes?
60. A computer user has downloaded 25 songs using an online file-sharing program and wants to create a CD-R with ten songs to use in his portable CD player. If the order that the songs are placed on the CD-R is important to him, how many different CD-Rs could he make from the 25 songs available to him?
61. In how many ways can 4 different pizza toppings be chosen from 12 available toppings?
62. At a baby shower 17 guests are in attendance and 5 of them are randomly selected to receive a door prize. If all 5 prizes are identical, in how many ways can the prizes be awarded? (Assume no one can receive more than one prize).
63. In the 6/50 lottery game, a player picks six numbers from 1 to 50. How many different choices does the player have if order doesn't matter?
64. In a lottery daily game, a player picks three numbers from 0 to 9. How many different choices does the player have if order doesn't matter?

65. How many ways can 5 different cards be dealt from a standard 52-card deck?
66. A jury pool consists of 18 people. How many different ways can 3 people be chosen to serve on a jury?
67. A jury pool consists of 27 people. How many different ways can 11 people be chosen to serve on a jury and one additional person be chosen to serve as the jury foreman?
68. The United States Senate Committee on Commerce, Science, and Transportation consists of 23 members, 12 Republicans and 11 Democrats. The Surface Transportation and Merchant Marine Subcommittee (STMMS) consist of 8 Republicans and 7 Democrats. How many ways can members of the STMMS be chosen from the Committee?
69. What is the probability that if 6 letters are typed, no letters are repeated?
70. Four letters are typed, without repetition. What is the probability that all 4 will be vowels?
71. Five letters are typed, with repetition allowed. What is the probability that all 5 will be vowels?
72. You own 16 CDs. You want to randomly arrange 5 of them in a CD rack. What is the probability that the rack ends up in alphabetical order?
73. A jury pool consists of 27 people, 14 men and 13 women. Compute the probability that a randomly selected jury of 12 people is all male.
74. In a lottery game, a player picks six numbers from 1 to 48. If 5 of the 6 numbers match those drawn, they player wins second prize. What is the probability of winning this prize?
75. In a lottery game, a player picks six numbers from 1 to 48. If 4 of the 6 numbers match those drawn, they player wins third prize. What is the probability of winning this prize?
76. Compute the probability that a 5-card poker hand is dealt to you that contains all hearts.
77. Compute the probability that a 5-card poker hand is dealt to you that contains four Aces.

Chapter 10 - Statistics

Chapter 10 Learning Objectives:

- Distinguish between a population and a sample
- Categorize data as either qualitative or quantitative
- Correctly identify the type of sampling method used
- Correctly identify the potential bias in a statistical study
- Determine whether a statistical study is an experiment or an observational study
- Classify the type of experimental study
- Use bar graphs and pie charts to graphically display data
- Use a histogram to graphically display data

Section 10.1 – Introduction to Statistics; Populations and Samples

Section 10.2 – Sampling Methods

Section 10.3 – How to Mess Things Up Before You Start

Section 10.4 – Experiments

Section 10.5 – Categorizing Data

Section 10.6 – Presenting Qualitative Data Graphically

Section 10.7 – Presenting Quantitative Data Graphically

Section 10.1 – Introduction to Statistics; Populations and Samples

It is important to be able to properly evaluate the data and claims that bombard you every day. If you cannot distinguish sound from faulty reasoning, then you are vulnerable to manipulation and to decisions that are not in your best interest. Statistics provides tools that you need in order to react intelligently to information you hear or read. In this sense, Statistics is one of the most important things that you can study.

To be more specific, here are some claims that we have heard on several occasions. (We are *not* saying that each one of these claims is true!)

- 4 out of 5 dentists recommend Dentyne.
- Almost 85% of lung cancers in men and 45% in women are tobacco-related.
- Condoms are effective 94% of the time.
- Native Americans are significantly more likely to be hit crossing the streets than are people of other ethnicities.
- People tend to be more persuasive when they look others directly in the eye and speak loudly and quickly.
- Women make 75 cents to every dollar a man makes when they work the same job.
- A surprising new study shows that eating egg whites can increase one's life span.
- People predict that it is very unlikely there will ever be another baseball player with a batting average over 400.

- There is an 80% chance that in a room full of 30 people that at least two people will share the same birthday.
- 79.48% of all statistics are made up on the spot.

All of these claims are statistical in character. We suspect that some of them sound familiar; if not, we bet that you have heard other claims like them. Notice how diverse the examples are; they come from psychology, health, law, sports, business, etc. Indeed, data and data-interpretation show up in discourse from virtually every facet of contemporary life.

Statistics are often presented in an effort to add credibility to an argument or advice. You can see this by paying attention to television advertisements. Many of the numbers thrown about in this way do not represent careful statistical analysis. They can be misleading, and push you into decisions that you might find cause to regret. These chapters will help you learn statistical essentials. It will make you into an intelligent consumer of statistical claims.

You can take the first step right away. To be an intelligent consumer of statistics, your first reflex must be to question the statistics that you encounter. The British Prime Minister Benjamin Disraeli famously said, "There are three kinds of lies -- lies, damned lies, and statistics." This quote reminds us why it is so important to understand statistics. So let us invite you to reform your statistical habits from now on. No longer will you blindly accept numbers or findings. Instead, you will begin to think about the numbers, their sources, and most importantly, the procedures used to generate them.

We have put the emphasis on defending ourselves against fraudulent claims wrapped up as statistics. Just as important as detecting the deceptive use of statistics is the appreciation of the proper use of statistics. You must also learn to recognize statistical evidence that supports a stated conclusion. Statistics are all around you, sometimes used well, sometimes not. We must learn how to distinguish the two cases.

Populations and Samples

Before we begin gathering and analyzing data we need to characterize the **population** we are studying. If we want to study the amount of money spent on textbooks by a typical first-year college student, our population might be all first-year students at your college. Or it might be:

- All first-year community college students in the state of Arizona.
- All first-year students at public colleges and universities in the state of Arizona.
- All first-year students at all colleges and universities in the state of Arizona.
- All first-year students at all colleges and universities in the entire United States.
- And so on.

Population

<p>The population of a study is the group the collected data is intended to describe. It is the entire group of objects or individuals of interest in a statistical study.</p>

Why is it important to specify the population? We might get different answers to our question as we vary the population we are studying. First-year students at Arizona State University might take slightly more diverse courses than those at your college, and some of these courses may require less popular textbooks that cost more; or, on the other hand, the University Bookstore might have a larger pool of used textbooks, reducing the cost of these books to the students. Whichever the case (and it is likely that some combination of these and other factors are in play), the data we gather from your college will probably not be the same as that from Arizona State University. Particularly when conveying our results to others, we want to be clear about the population we are describing with our data.

Example 1

<p>A poll is conducted to determine whether people intend to vote for or against an upcoming proposition in Maricopa County. What is the population?</p>
--

<p>The population of interest in this case is all registered voters in Maricopa County.</p>

Example 2

<p>A newspaper website contains a poll asking people their opinion on a recent news article. What is the population?</p>
--

<p>While the intended population may have been all people, the real population of the survey is readers of the website.</p>

The previous example demonstrates a potential problem with how the data used in a statistical study is actually collected. We will come back to this concept when we learn about sampling methods later in this chapter.

If we were able to gather data on every member of our population, say the average (we will define "average" more carefully in a subsequent section) amount of money spent on textbooks by each first-year student at your college during the 2009-2010 academic year, the resulting number would be called a **parameter**.

Parameter

<p>A parameter is a value (average, percentage, etc.) calculated using all the data from a population.</p>

We seldom see parameters, however, since surveying an entire population is usually very time-consuming and expensive, unless the population is very small or we already have the data collected.

Census

A survey of an entire population is called a **census**.

You are probably familiar with two common censuses: the official government Census that attempts to count the population of the U.S. every ten years, and voting, which asks the opinion of all eligible voters in a district. The first of these demonstrates one additional problem with a census: the difficulty in finding and getting participation from everyone in a large population, which can bias, or skew, the results.

There are occasionally times when a census is appropriate, usually when the population is fairly small. For example, if the manager of Starbucks wanted to know the average number of hours her employees worked last week, she should be able to pull up payroll records or ask each employee directly.

Since surveying an entire population is often impractical, we usually select a **sample** to study;

Sample

A **sample** is a smaller subset of the entire population, ideally one that is fairly representative of the whole population.

We will discuss sampling methods in greater detail in a later section. For now, let us assume that samples are chosen in an appropriate manner. If we survey a sample, say 100 first-year students at your college, and find the average amount of money spent by these students on textbooks, the resulting number is called a **statistic**.

Statistic

A **statistic** is a value (average, percentage, etc.) calculated using the data from a sample.

Example 3

A researcher wanted to know how citizens of Tacoma felt about a voter initiative. To study this, she goes to the Tacoma Mall and randomly selects 500 shoppers and asks them their opinion. 60% indicate they are supportive of the initiative. What is the sample and population? Is the 60% value a parameter or a statistic?

The sample is the 500 shoppers questioned. The population is less clear. While the intended population of this survey was Tacoma citizens, the effective population was mall shoppers. There is no reason to assume that the 500 shoppers questioned would be representative of all Tacoma citizens.

The 60% value was based on the sample, so it is a statistic.

You Try 10.1

- a. To determine the average length of trout in a lake, researchers catch 20 fish and measure them. What is the sample and population in this study?
- b. A college reports that the average age of their students is 28 years old. Is this a statistic or a parameter?

Section 10.2 – Sampling Methods

As we mentioned in a previous section, the first thing we should do before conducting a survey is to identify the population that we want to study. Suppose we are hired by a politician to determine the amount of support he has among the electorate should he decide to run for another term. What population should we study? Every person in the district? Not every person is eligible to vote, and regardless of how strongly someone likes or dislikes the candidate, they don't have much to do with him being re-elected if they are not able to vote.

What about eligible voters in the district? That might be better, but if someone is eligible to vote but does not register by the deadline, they won't have any say in the election either. What about registered voters? Many people are registered but choose not to vote. What about "likely voters?"

This is the criteria used in much political polling, but it is sometimes difficult to define a "likely voter." Is it someone who voted in the last election? In the last general election? In the last presidential election? Should we consider someone who just turned 18 a "likely voter?" They weren't eligible to vote in the past, so how do we judge the likelihood that they will vote in the next election?

In November 1998, former professional wrestler Jesse "The Body" Ventura was elected governor of Minnesota. Up until right before the election, most polls showed he had little chance of winning. There were several contributing factors to the polls not reflecting the actual intent of the electorate:

- Ventura was running on a third-party ticket and most polling methods are better suited to a two-candidate race.

- Many respondents to polls may have been embarrassed to tell pollsters that they were planning to vote for a professional wrestler.
- The mere fact that the polls showed Ventura had little chance of winning might have prompted some people to vote for him in protest to send a message to the major-party candidates.

But one of the major contributing factors was that Ventura recruited a substantial amount of support from young people, particularly college students, who had never voted before and who registered specifically to vote in the gubernatorial election. The polls did not deem these young people likely voters (since in most cases young people have a lower rate of voter registration and a turnout rate for elections) and so the polling samples were subject to **sampling bias**: they omitted a portion of the electorate that was weighted in favor of the winning candidate.

Sampling Bias

A sampling method is biased if some members of the population have a smaller likelihood of being included in the sample than other members of the population.

So even identifying the population can be a difficult job, but once we have identified the population, how do we choose an appropriate sample? Remember, although we would prefer to survey all members of the population, this is usually impractical unless the population is very small, so we choose a sample. There are many ways to sample a population, but there is one goal we need to keep in mind: we would like the sample to be *representative of the population*.

Returning to our hypothetical job as a political pollster, we would not anticipate very accurate results if we drew all of our samples from among the customers at a Starbucks, nor would we expect that a sample drawn entirely from the membership list of the local Elks club would provide a useful picture of district-wide support for our candidate.

One way to ensure that the sample has a reasonable chance of mirroring the population is to employ *randomness*. The most basic random method is simple random sampling.

Simple Random Sample

A **random sample** is one in which each member of the population has an equal probability of being chosen for the sample. A **simple random sample** is one in which every member of the population and any group of members has an equal probability of being chosen.

Example 4

If we could somehow identify all likely voters in the state, put each of their names on a piece of paper, toss the slips into a (very large) hat and draw 1000 slips out of the hat, we would have a simple random sample.

In practice, computers are better suited for this sort of endeavor than millions of slips of paper and extremely large headgear.

It is always possible, however, that even a random sample might end up not being totally representative of the population. If we repeatedly take samples of 1000 people from among the population of likely voters in the state of Arizona, some of these samples might tend to have a slightly higher percentage of Democrats (or Republicans) than does the general population; some samples might include more older people and some samples might include more younger people; etc. For large samples, this **sampling variability** is not significant.

Sampling Variability

The natural variation of samples is called **sampling variability**. This is unavoidable and expected in random sampling, and in large samples is not an issue.

To help account for variability, pollsters might instead use a **stratified sample**.

Stratified Sampling

In **stratified sampling**, a population is divided into a number of subgroups (or strata). Random samples are then taken from each subgroup with sample sizes proportional to the size of the subgroup in the population.

Example 5

Suppose in a particular state that previous data indicated that the electorate was comprised of 39% Democrats, 37% Republicans and 24% independents. In a sample of 1000 people, they would then expect to get about 390 Democrats, 370 Republicans and 240 independents. To accomplish this, they could randomly select 390 people from among those voters known to be Democrats, 370 from those known to be Republicans, and 240 from those with no party affiliation.

Stratified sampling can also be used to select a sample with people in desired age groups, a specified mix ratio of males and females, etc.

Another sampling method is **cluster sampling**, in which the population is divided into groups, and one or more groups are randomly selected to be in the sample.

Cluster Sampling

In **cluster sampling**, the population is divided into subgroups (clusters), and a set of subgroups are selected to be in the sample.

Example 6

If the college wanted to survey students, since students are already divided into classes, they could randomly select 10 classes and give the survey to all the students in those classes. This would be cluster sampling.

Another common sampling method is **systematic sampling**.

Systematic Sampling

In **systematic sampling**, every n^{th} member of the population is selected to be in the sample.

Example 7

To select a sample using systematic sampling, a pollster calls every 100th name in the phone book.

Systematic sampling is not as random as a simple random sample (if your name is Albert Aardvark and your sister Alexis Aardvark is right after you in the phone book, there is no way you could both end up in the sample) but it can yield acceptable samples.

Perhaps the worst types of sampling methods are **convenience samples** and **voluntary response samples**.

Convenience Sampling and Voluntary Response Sampling

Convenience sampling is samples chosen by selecting whoever is convenient.

Voluntary response sampling is allowing the sample to volunteer.

Example 8

A pollster stands on a street corner and interviews the first 100 people who agree to speak to him. This is a convenience sample.

Example 9

A website has a survey asking readers to give their opinion on a tax proposal. This is a self-selected sample, or voluntary response sample, in which respondents volunteer to participate.

Usually voluntary response samples are skewed towards people who have a particularly strong opinion about the subject of the survey or who just have way too much time on their hands and enjoy taking surveys.

You Try 10.2

In each case, indicate what sampling method was used

- Every 4th person in the class was selected
- A sample was selected to contain 25 men and 35 women
- Viewers of a new show are asked to vote on the show's website
- A website randomly selects 50 of their customers to send a satisfaction survey to
- To survey voters in a town, a polling company randomly selects 10 city blocks, and interviews everyone who lives on those blocks.

Section 10.3 – How to Mess Things Up Before You Start

There are number of ways that a study can be ruined before you even start collecting data. The first we have already explored – **sampling** or **selection bias**, which is when the sample is not representative of the population. One example of this is **voluntary response bias**, which is bias introduced by only collecting data from those who volunteer to participate. This is not the only potential source of bias.

Sources of Bias

Sampling bias – when the sample is not representative of the population

Voluntary response bias – the sampling bias that often occurs when the sample is volunteers

Self-interest study – bias that can occur when the researchers have an interest in the outcome

Response bias – when the responder gives inaccurate responses for any reason

Perceived lack of anonymity – when the responder fears giving an honest answer might negatively affect them

Non-response bias – when people refusing to participate in the study can influence the validity of the outcome

Loaded questions – when the question wording influences the responses

Example 10

Consider a recent study which found that chewing gum may raise math grades in teenagers⁹. This study was conducted by the Wrigley Science Institute, a branch of the Wrigley chewing gum company. This is an example of a **self-interest study**; one in

⁹ Reuters. http://news.yahoo.com/s/nm/20090423/od_uk_nm/oukoe_uk_gum_learning. Retrieved 4/27/09

which the researchers have a vested interest in the outcome of the study. While this does not necessarily ensure that the study was biased, it certainly suggests that we should subject the study to extra scrutiny.

Example 11

A survey asks people “when was the last time you visited your doctor?” This might suffer from **response bias**, since many people might not remember exactly when they last saw a doctor and give inaccurate responses.

Sources of response bias may be innocent, such as bad memory, or as intentional as pressuring by the pollster. Consider, for example, how many voting initiative petitions people sign without even reading them.

Example 12

A survey asks participants a question about their interactions with members of other races. Here, a **perceived lack of anonymity** could influence the outcome. The respondent might not want to be perceived as racist even if they are, and give an untruthful answer.

Example 13

An employer puts out a survey asking their employees if they have a drug abuse problem and need treatment help. Here, a **perceived lack of anonymity** could influence the outcome. Answering truthfully might have consequences; responses might not be accurate if the employees do not feel their responses are anonymous or fear retribution from their employer.

Example 14

A telephone poll asks the question “Do you often have time to relax and read a book?”, and 50% of the people called refused to answer the survey. It is unlikely that the results will be representative of the entire population. This is an example of **non-response bias**, introduced by people refusing to participate in a study or dropping out of an experiment. When people refuse to participate, we can no longer be so certain that our sample is representative of the population.

Example 15

A survey asks “do you support funding research of alternative energy sources to reduce our reliance on high-polluting fossil fuels?” This is an example of a **loaded or leading question** – questions whose wording leads the respondent towards an answer.

Loaded questions can occur intentionally by pollsters with an agenda, or accidentally through poor question wording. Also a concern is **question order**, where the order of questions changes the results. A psychology researcher provides an example¹⁰:

“My favorite finding is this: we did a study where we asked students, 'How satisfied are you with your life? How often do you have a date?' The two answers were not statistically related - you would conclude that there is no relationship between dating frequency and life satisfaction. But when we reversed the order and asked, 'How often do you have a date? How satisfied are you with your life?' the statistical relationship was a strong one. You would now conclude that there is nothing as important in a student's life as dating frequency.”

You Try 10.3

In each situation, identify a potential source of bias:

- A survey asks how many sexual partners a person has had in the last year
- A radio station asks readers to phone in their choice in a daily poll.
- A substitute teacher wants to know how students in the class did on their last test. The teacher asks the 10 students sitting in the front row to state their latest test score.
- High school students are asked if they have consumed alcohol in the last two weeks.
- The Beef Council releases a study stating that consuming red meat poses little cardiovascular risk.
- A poll asks “Do you support a new transportation tax, or would you prefer to see our public transportation system fall apart?”

Section 10.4 – Experiments

So far, we have primarily discussed **observational studies** – studies in which conclusions would be drawn from observations of a sample or the population. In some cases these observations might be unsolicited, such as studying the percentage of cars that turn right at a red light even when there is a “no turn on red” sign. In other cases the observations are solicited, like in a survey or a poll.

In contrast, it is common to use **experiments** when exploring how subjects react to an outside influence. In an experiment, some kind of **treatment and/or control** is applied to the subjects and the results are measured and recorded.

Observational Studies and Experiments

An **observational study** is a study based on observations or measurements.

An **experiment** is a study in which the effects of a **treatment** are measured.

Here are some examples of experiments:

¹⁰ Swartz, Norbert. <http://www.umich.edu/~newsinfo/MT/01/Fal01/mt6f01.html>. Retrieved 3/31/2009

Example 16

- a. A pharmaceutical company tests a new medicine for treating Alzheimer’s disease by administering the drug to 50 elderly patients with recent diagnoses. The treatment here is the new drug.
- b. A gym tests out a new weight loss program by enlisting 30 volunteers to try out the program. The treatment here is the new program.
- c. You test a new kitchen cleaner by buying a bottle and cleaning your kitchen. The new cleaner is the treatment.
- d. A psychology researcher explores the effect of music on temperament by measuring people’s temperament while listening to different types of music. The music is the treatment.

You Try 10.4

Determine which of the scenarios below describe an observational study and which describe an experiment? If it is an experiment, identify the treatment.

- a. The weights of 30 randomly selected people are measured
- b. Subjects are asked to do 20 jumping jacks, and then their heart rates are measured
- c. 20 people are given a concentration test after drinking a cup of coffee.

When conducting experiments, it is essential to isolate the treatment being tested.

Suppose a middle school (junior high) finds that their students are not scoring well on the state’s standardized math test. They decide to run an experiment to see if an alternate curriculum would improve scores. To run the test, they hire a math specialist to come in and teach a class using the new curriculum. To their delight, they see an improvement in test scores.

The difficulty with this scenario is that it is not clear whether the curriculum is responsible for the improvement, or whether the improvement is due to a math specialist teaching the class. This is called **confounding** – when it is not clear which factor or factors caused the observed effect. Confounding is the downfall of many experiments, though sometimes it is hidden.

Confounding

Confounding occurs when there are two or more potential variables that could have caused the outcome and it is not possible to determine which actually caused the result.

Example 17

A drug company study about a weight loss pill might report that people lost an average of 8 pounds while using their new drug. However, in the fine print you find a statement saying that participants were encouraged to also diet and exercise. It is not clear in this

case whether the weight loss is due to the pill, to diet and exercise, or a combination of both. In this case confounding has occurred.

Example 18

Researchers conduct an experiment to determine whether students will perform better on an arithmetic test if they listen to music during the test. They first give the student a test without music, then give a similar test while the student listens to music. In this case, the student might perform better on the second test, regardless of the music, simply because it was the second test and they were warmed up.

There are a number of measures that can be introduced to help reduce the likelihood of confounding. The primary measure is to use a **control group**.

Control Group

When using a control group, the participants are divided into two or more groups, typically a **control group** and a treatment group. The treatment group receives the treatment being tested; the control group does not receive the treatment.

Ideally, the groups are otherwise as similar as possible, isolating the treatment as the only potential source of difference between the groups. For this reason, the method of dividing groups is important. Some researchers attempt to ensure that the groups have similar characteristics (same number of females, same number of people over 50, etc.), but it is nearly impossible to control for every characteristic. Because of this, random assignment is very commonly used.

Example 19

To determine if a two day prep course would help high school students improve their scores on the SAT test, a group of students was randomly divided into two subgroups. The first group, the treatment group, was given a two day prep course. The second group, the control group, was not given the prep course. Afterwards, both groups were given the SAT.

Example 20

A company testing a new plant food grows two crops of plants in adjacent fields, the treatment group receiving the new plant food and the control group not. The crop yield would then be compared. By growing them at the same time in adjacent fields, they are controlling for weather and other confounding factors.

Sometimes not giving the control group anything does not completely control for confounding variables. For example, suppose a medicine study is testing a new headache pill by giving the treatment group the pill and the control group nothing. If the treatment

group showed improvement, we would not know whether it was due to the medicine in the pill, or a response to have taken any pill. This is called a **placebo effect**.

Placebo Effect

The **placebo effect** is when the effectiveness of a treatment is influenced by the patient's perception of how effective they think the treatment will be, so a result might be seen even if the treatment is ineffectual.

Example 21

A study found that when doing painful dental tooth extractions, patients told they were receiving a strong painkiller while actually receiving a saltwater injection found as much pain relief as patients receiving a dose of morphine.¹¹

To control for the placebo effect, a **placebo**, or dummy treatment, is often given to the control group. This way, both groups are truly identical except for the specific treatment given.

Placebo and Placebo Controlled Experiments

A **placebo** is a dummy treatment given to control for the placebo effect. An experiment that gives the control group a placebo is called a **placebo controlled experiment**.

Example 22

- a. In a study for a new medicine that is dispensed in a pill form, a sugar pill could be used as a placebo.
- b. In a study on the effect of alcohol on memory, a non-alcoholic beer might be given to the control group as a placebo.
- c. In a study of a frozen meal diet plan, the treatment group would receive the diet food, and the control could be given standard frozen meals stripped of their original packaging.

In some cases, it is more appropriate to compare to a conventional treatment than a placebo. For example, in a cancer research study, it would not be ethical to deny any treatment to the control group or to give a placebo treatment. In this case, the currently acceptable medicine would be given to the second group, called a **comparison group** in this case. In our SAT test example, the non-treatment group would most likely be encouraged to study on their own, rather than be asked to not study at all, to provide a meaningful comparison.

¹¹ Levine JD, Gordon NC, Smith R, Fields HL. (1981) Analgesic responses to morphine and placebo in individuals with postoperative pain. Pain. 10:379-89.

When using a placebo, it would defeat the purpose if the participant knew they were receiving the placebo.

Blind Studies

A **blind study** is one in which the participant does not know whether or not they are receiving the treatment or a placebo.

A **double-blind study** is one in which neither the participants, nor those interacting with the participants, know who is in the treatment group and who is in the control group.

Example 23

In a study about anti-depression medicine, you would not want the psychological evaluator to know whether the patient is in the treatment or control group either, as it might influence their evaluation, so the experiment should be conducted as a double-blind study.

It should be noted that not every experiment needs a control group.

Example 24

If a researcher is testing whether a new fabric can withstand fire, she simply needs to torch multiple samples of the fabric – there is no need for a control group.

Example 25

To test a new lie detector, two groups of subjects are given the new test. One group is asked to answer all the questions truthfully, and the second group is asked to lie on one set of questions. The person administering the lie detector test does not know what group each subject is in.

In this example, the truth-telling group could be considered the control group, but really both groups are treatment groups here, since it is important for the lie detector to be able to correctly identify lies, and also not identify truth telling as lying. This study is blind, since the person running the test does not know what group each subject is in.

Section 10.5 – Categorizing Data

Once we have gathered data, we might wish to classify it. Roughly speaking, data can be classified as categorical data or quantitative data.

Quantitative and Categorical (Qualitative) Data

Categorical (qualitative) data are pieces of information that allow us to classify the objects under investigation into various categories.

Quantitative data are responses that are numerical in nature and with which we can perform meaningful arithmetic calculations.

Example 26

We might conduct a survey to determine the name of the favorite movie that each person in a math class saw in a movie theater.

When we conduct such a survey, the responses would look like: *Finding Nemo*, *The Hulk*, or *Terminator 3: Rise of the Machines*. We might count the number of people who give each answer, but the answers themselves do not have any numerical values: we cannot perform computations with an answer like "*Finding Nemo*." This would be categorical data.

Example 27

A survey could ask the number of movies you have seen in a movie theater in the past 12 months (0, 1, 2, 3, 4, ...)

This would be quantitative data.

Other examples of quantitative data would be the running time of the movie you saw most recently (104 minutes, 137 minutes, 104 minutes, ...) or the amount of money you paid for a movie ticket the last time you went to a movie theater (\$5.50, \$7.75, \$9, ...).

Sometimes, determining whether or not data is categorical or quantitative can be a bit trickier.

Example 28

Suppose we gather respondents' ZIP codes in a survey to track their geographical location.

ZIP codes are numbers, but we can't do any meaningful mathematical calculations with them (it doesn't make sense to say that 98036 is "twice" 49018 — that's like saying that Lynnwood, WA is "twice" Battle Creek, MI, which doesn't make sense at all), so ZIP codes are really categorical data.

Example 29

A survey about the movie you most recently attended includes the question "How would you rate the movie you just saw?" with these possible answers:

- 1 - it was awful
- 2 - it was just OK
- 3 - I liked it
- 4 - it was great
- 5 - best movie ever!

Again, there are numbers associated with the responses, but we can't really do any calculations with them: a movie that rates a 4 is not necessarily twice as good as a movie that rates a 2, whatever that means; if two people see the movie and one of them thinks it stinks and the other thinks it's the best ever it doesn't necessarily make sense to say that "on average they liked it."

As we study movie-going habits and preferences, we shouldn't forget to specify the population under consideration. If we survey 3-7 year-olds the runaway favorite might be *Finding Nemo*. 13-17 year-olds might prefer *Terminator 3*. And 33-37 year-olds might prefer...well, *Finding Nemo*.

You Try 10.5

Classify each measurement as categorical or quantitative

- a. Eye color of a group of people
- b. Daily high temperature of a city over several weeks
- c. Annual income

Once we have collected data from surveys or experiments, we need to summarize and present the data in a way that will be meaningful to the reader. We will begin with graphical presentations of data then explore numerical summaries of data.

Section 10.6 – Presenting Categorical Data Graphically

Categorical, or qualitative, data are pieces of information that allow us to classify the objects under investigation into various categories. We usually begin working with categorical data by summarizing the data into a **frequency table**.

Frequency Table

A frequency table is a table with two columns. One column lists the possible values of the variable, and the other lists the corresponding frequency for each value (how many items fit into each category).

Many times a 3rd column is added, called the relative frequency column. The relative frequency expresses the frequency of each possible value, relative to the whole. Relative frequencies can be written as fractions, decimals, or percentages.

Example 30

An insurance company determines vehicle insurance premiums based on known risk factors. If a person is considered a higher risk, their premiums will be higher. One potential factor is the color of your car. The insurance company believes that people with some color cars are more likely to get in accidents. To research this, they examine police reports for recent total-loss collisions. The data is summarized in the frequency table below.

Color	Frequency
Blue	25
Green	52
Red	41
White	36
Black	39
Grey	23

When you add together the frequencies for each possible value of the variable, you end up with the total number of observed values. In this case, that total is 216.

If we wanted to add a relative frequency column, we would find the relative frequency for each color by dividing the corresponding frequency by the total number of observations. The new table would be as follows:

Color	Frequency	Relative Frequency
Blue	25	$\frac{25}{216} = .1157 = 11.57\%$
Green	52	$\frac{52}{216} = .2407 = 24.07\%$
Red	41	$\frac{41}{216} = .1898 = 18.98\%$
White	36	$\frac{36}{216} = .1667 = 16.67\%$
Black	39	$\frac{39}{216} = .1806 = 18.06\%$
Grey	23	$\frac{23}{216} = .1065 = 10.65\%$

Note: The relative frequency column should always sum to 1 (or 100%) since you are representing the entire data set.

Sometimes we need an even more intuitive way of displaying data. This is where charts and graphs come in. There are many, many ways of displaying data graphically, but we

will concentrate on one very useful type of graph called a bar graph. In this section we will work with bar graphs that display categorical data; the next section will be devoted to histograms that display quantitative data.

Bar Graphs

A **bar graph** is a graph that displays a bar for each category with the length of each bar indicating the frequency of that category.

To construct a bar graph, we need to draw a vertical axis and a horizontal axis. The vertical direction will have a scale and measure the frequency of each category; the horizontal axis has no scale in this instance, and represents the possible values of the variable of interest. The construction of a bar chart is most easily described by use of an example.

Example 31

Using our car data from above, note the highest frequency is 52, so our vertical axis needs to go from 0 to 52, but we might as well use 0 to 55, so that we can put a hash mark every 5 units:

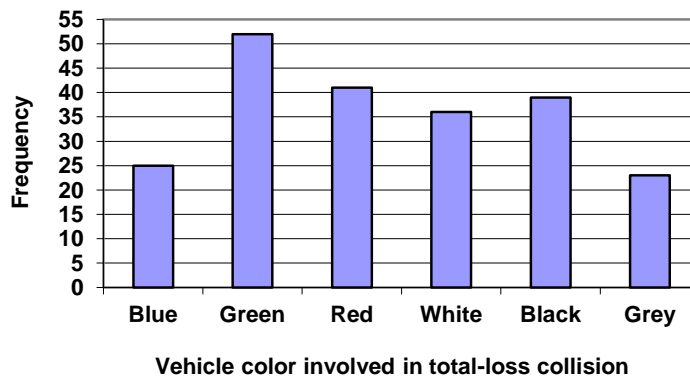

Notice that the height of each bar is determined by the frequency of the corresponding color. The horizontal gridlines are a nice touch, but not necessary. In practice, you will find it useful to draw bar graphs using graph paper, so the gridlines will already be in place, or using technology. Instead of gridlines, we might also list the frequencies at the top of each bar, like this:

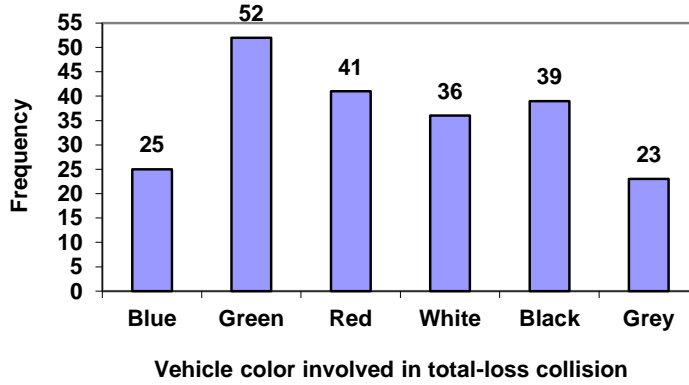

In this case, our chart might benefit from being reordered from largest to smallest frequency values. This arrangement can make it easier to compare similar values in the chart, even without gridlines. When we arrange the categories in decreasing frequency order like this, it is called a **Pareto chart**.

Pareto Chart

A **Pareto chart** is a bar graph ordered from highest to lowest frequency

Example 32

Transforming our bar graph from earlier into a Pareto chart, we get:

Vehicle color	Frequency
Green	52
Red	41
Black	39
White	36
Blue	25
Grey	23

Example 33

In a survey¹², adults were asked whether they personally worried about a variety of environmental concerns. The numbers (out of 1012 surveyed) who indicated that they worried “a great deal” about some selected concerns are summarized below.

Environmental Issue	Frequency
Pollution of drinking water	597
Contamination of soil and water by toxic waste	526
Air pollution	455
Global warming	354

This data could be shown graphically in a bar graph:

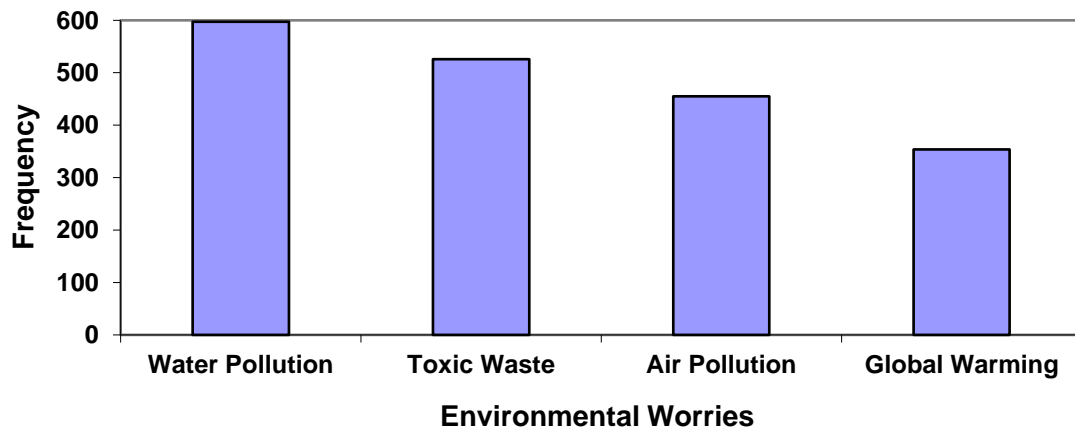
**You Try 10.6A**

Create a frequency table and bar graph to illustrate the grades on a history exam below.

A: 12 students, B: 19 students, C: 14 students, D: 4 students, F: 5 students

To show relative sizes, it is common to use a pie chart.

Pie Chart

A **pie chart** is a circle with wedges cut of varying sizes marked out like slices of pie or pizza. The relative sizes of the wedges correspond to the relative frequencies of the categories. These relative frequencies are usually expressed as a percentage.

¹² Gallup Poll. March 5-8, 2009. <http://www.pollingreport.com/enviro.htm>

Example 34

For our vehicle color data, a pie chart might look like this:

Vehicle color involved in total-loss collisions

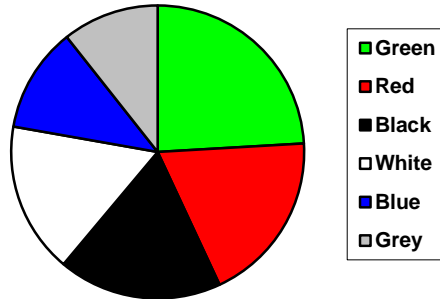

Pie charts can often benefit from including frequencies or relative frequencies (percentages) in the chart next to the pie slices. Often having the category names next to the pie slices also makes the chart clearer.

Vehicle color involved in total-loss collisions

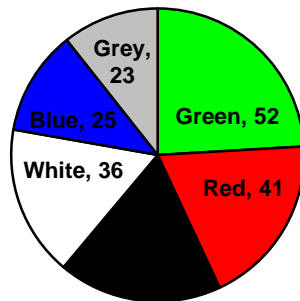

Example 35

The pie chart to the right shows the percentage of voters supporting each candidate running for a local senate seat.

If there are 20,000 voters in the district, the pie chart shows that about 11% of those, about 2,200 voters, support Reeves.

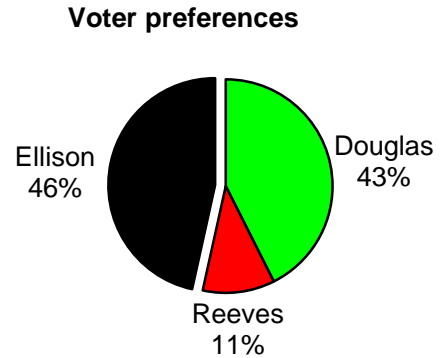

Pie charts look nice, but are harder to draw by hand than bar charts since to draw them accurately we would need to compute the angle each wedge cuts out of the circle, then measure the angle with a protractor. Computers are much better suited to drawing pie charts. Common software programs like Microsoft Word or Excel, OpenOffice.org, Write or Calc, or Google Docs are able to create bar graphs, pie charts, and other graph types. There are also numerous online tools that can create graphs¹³.

You Try 10.6B

Logan categorized his spending for this month into four categories: Rent, Food, Fun, and Other. The percentages he spent in each category are pictured here. If Logan spent a total of \$2400 this month, how much did he spend on Food?

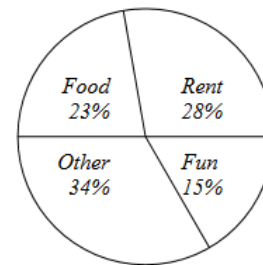

¹³ For example: <http://nces.ed.gov/nceskids/createAgraph/> or <http://docs.google.com>

Don't get fancy with graphs! People sometimes add features to graphs that don't help to convey their information. For example, 3-dimensional bar charts like the one shown below are usually not as effective as their two-dimensional counterparts.

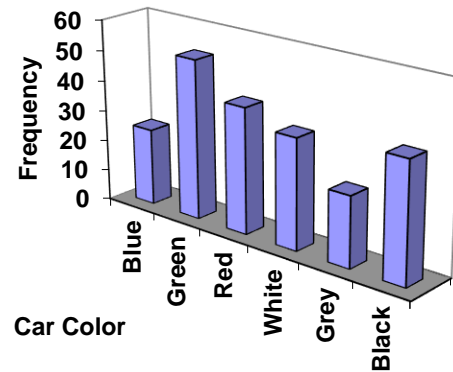

Here is another way that fanciness can lead to trouble. Instead of plain bars, it is tempting to substitute meaningful images. This type of graph is called a **pictogram**.

Pictogram

A **pictogram** is a statistical graphic in which the size of the picture is intended to represent the frequencies or size of the values being represented.

Example 36

A labor union might produce the graph to the right to show the difference between the average manager salary and the average worker salary.

Looking at the picture, it would be reasonable to guess that the manager salaries is 4 times as large as the worker salaries – the area of the bag looks about 4 times as large. However, the manager salaries are in fact only twice as large as worker salaries, which were reflected in the picture by making the manager bag twice as tall.



Manager Salaries



Worker Salaries

Another distortion in bar charts results from setting the baseline to a value other than zero. The baseline is the bottom of the vertical axis, representing the least number of cases that could have occurred in a category. Normally, this number should be zero.

Example 37

Compare the two graphs below showing support for same-sex marriage rights from a poll taken in December, 2008¹⁴. The difference in the vertical scale on the first graph

¹⁴CNN/Opinion Research Corporation Poll. Dec 19-21, 2008, from <http://www.pollingreport.com/civil.htm>

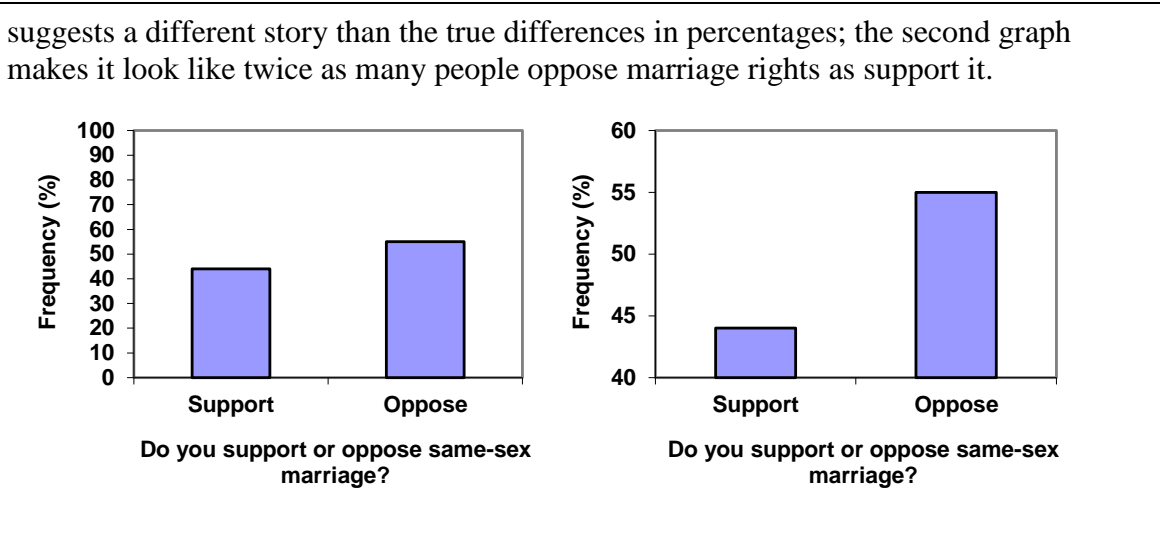

You Try 10.6C

A poll was taken asking people if they agreed with the positions of the 4 candidates for a county office. Does the pie chart present a good representation of this data? Explain.

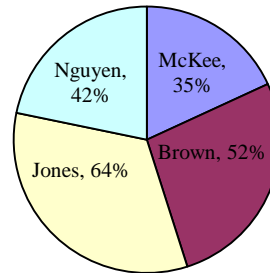

Section 10.7 – Presenting Quantitative Data Graphically

Quantitative, or numerical, data can also be summarized into frequency tables.

Example 38

A teacher records scores on a 20-point quiz for the 30 students in his class.

The scores are:

19 20 18 18 17 18 19 17 20 18 20 16 20 15 17 12 18 19 18 19 17 20 18 16 15 18 20 5 0 0

These scores could be summarized into a frequency table by grouping like values:

Score	Frequency
0	2
5	1
12	1
15	2
16	2
17	4
18	8
19	4
20	6

Using this table, it seems like we could create a standard bar chart from this summary, like we did for categorical data:

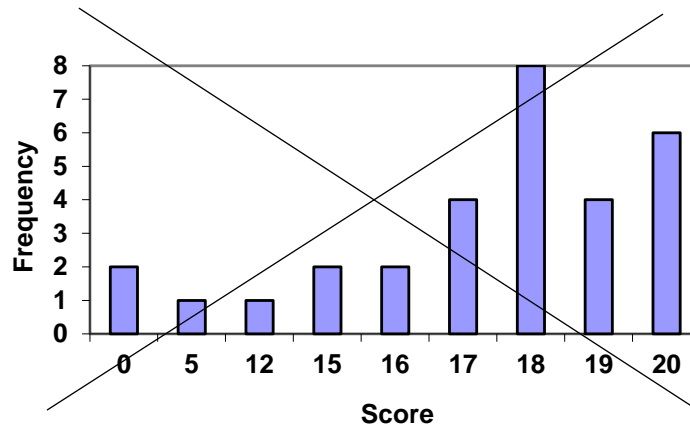

However, since the scores are numerical values, the bar graph above doesn't really make sense; the first and second bars are five values apart, while the later bars are only one value apart. It would be more correct to treat the horizontal axis as a *number line*. This type of graph is called a **histogram**.

Histogram

A **histogram** is like a bar graph, but where the horizontal axis is a number line.

The vertical axis still represents frequency, and the horizontal axis still represents the variable of interest.

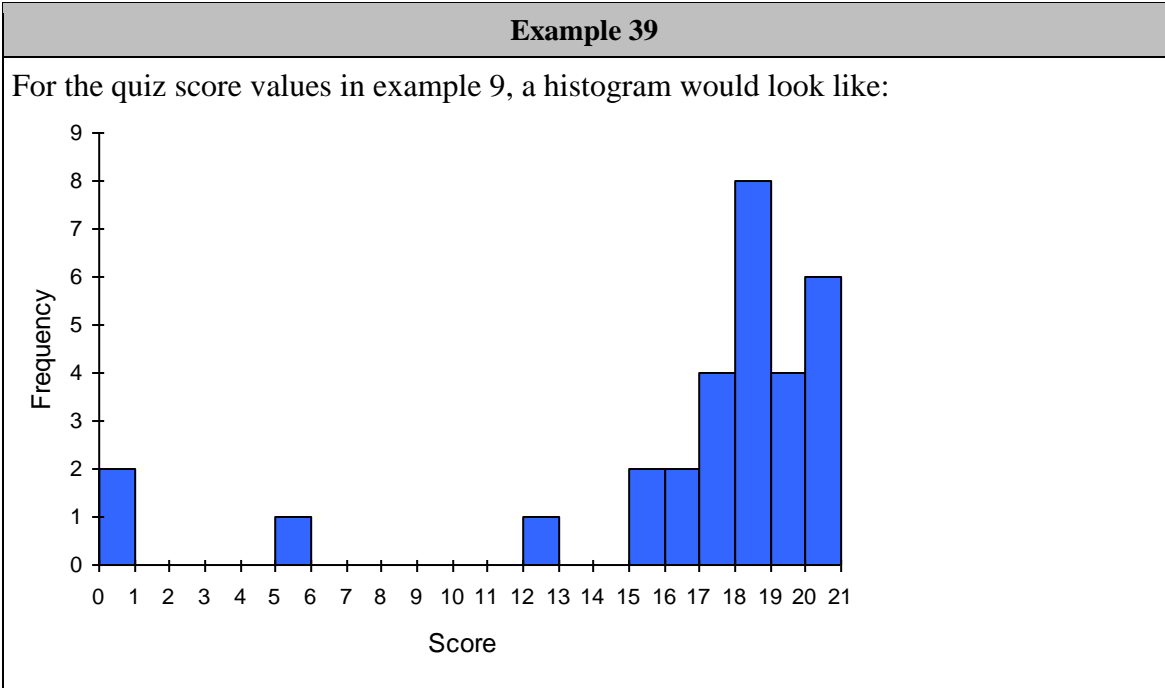

Notice that in the histogram, a bar represents values on the horizontal axis from that on the left hand-side of the bar up to, but not including, the value on the right hand side of the bar. Some people choose to have bars start at $\frac{1}{2}$ values to avoid this ambiguity.

Unfortunately, not a lot of common software packages can correctly graph a histogram.

Fortunately, your graphing calculator can quickly create an accurate histogram using the STAT PLOT option.

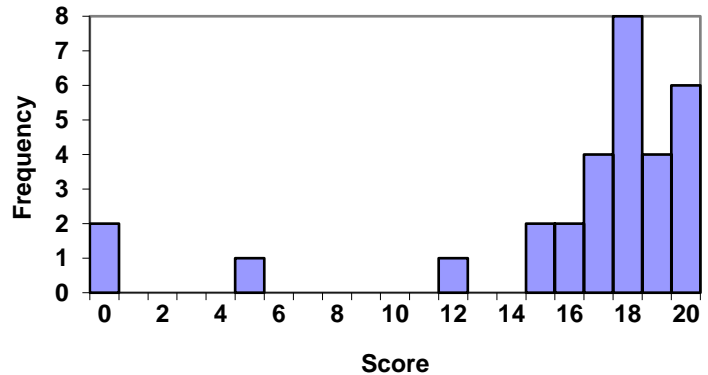

If we have a large number of widely varying data values, creating a frequency table that lists every possible value as a category would lead to an exceptionally long frequency table, and probably would not reveal any patterns. For this reason, it is common with quantitative data to group data into **class intervals**.

Class Intervals

Class intervals are groupings of the data. In general, we define class intervals so that:

- Each interval is equal in size. For example, if the first class contains values from 120-129, the second class should include values from 130-139.
- We have somewhere between 5 and 20 classes, typically, depending upon the number of data we're working with.

Example 40

Suppose that we have collected weights from 100 male subjects as part of a nutrition study. For our weight data, we have values ranging from a low of 121 pounds to a high of 263 pounds, giving a total span of $263 - 121 = 142$. We could create 7 intervals with a width of around 20, 14 intervals with a width of around 10, or somewhere in between. Often time we have to experiment with a few possibilities to find something that represents the data well. Let us try using an interval width of 15. We could start at 121, or at 120 since it is a nice round number.

Interval	Frequency
120 - 134	4
135 - 149	14
150 - 164	16
165 - 179	28
180 - 194	12
195 - 209	8
210 - 224	7
225 - 239	6
240 - 254	2
255 - 269	3

A histogram of this data would look like:

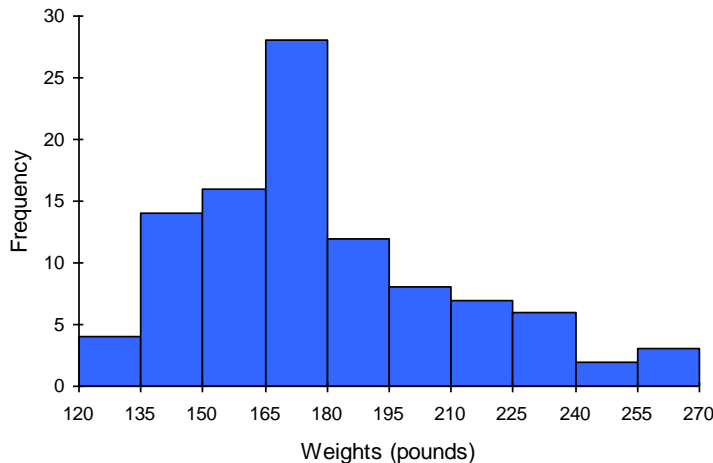

In many software packages, you can create a graph similar to a histogram by putting the class intervals as the labels on a bar chart.

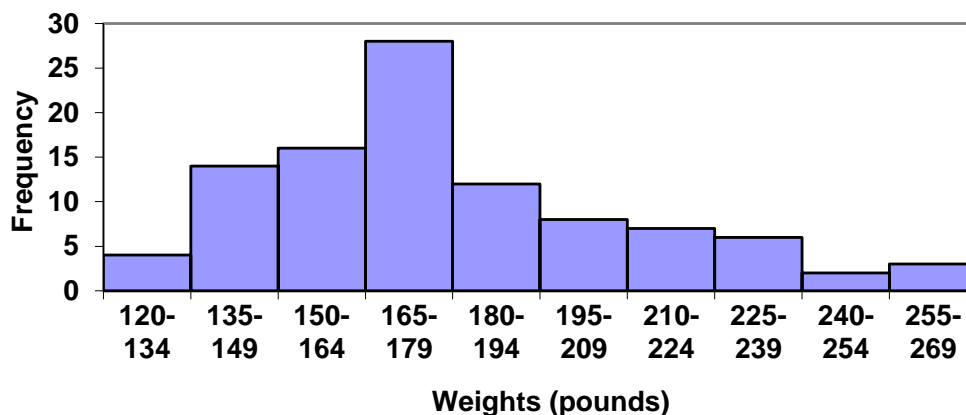

You Try 10.7

The total cost of textbooks for the term was collected from 36 students. Create a histogram for this data.

\$140	\$160	\$160	\$165	\$180	\$220	\$235	\$240	\$250	\$260	\$280	\$285
\$285	\$285	\$290	\$300	\$300	\$305	\$310	\$310	\$315	\$315	\$320	\$320
\$330	\$340	\$345	\$350	\$355	\$360	\$360	\$380	\$395	\$420	\$460	\$460

Calculator Instructions for Drawing a Histogram Using a TI-83/84:

1. Turn on the calculator
2. Press the “STAT” key
3. Hit “Enter” on option 1: “Edit”

This will bring you to a screen that contains lists: L1, L2, L3, etc.

3. Enter the data values (one value per row) into L1. For any negative values you need to use the (-) key, not the subtraction key. Continue until all data is entered into L1.
4. Press the 2nd key and then “STAT PLOT” (top left of calculator)
5. Press “Enter” on 1: “Plot 1”
6. Use the arrows to “ON” to turn on Plot 1. Hit “Enter”.
7. Use the arrows to go to the histogram picture and hit “Enter”.
8. Make sure that Xlist displays L1
9. Press the 2nd key and then “STAT PLOT” again.

Make sure to turn off all other stat plots, and clear all equations before graphing the histogram.

10. Press the ZOOM menu.
11. Scroll down to option 9: “ZoomStat” and hit “Enter”.

Chapter 10 – Answers to You Try Problems

- 10.1. a. The sample is the 20 fish caught. The population is all fish in the lake. The sample may be somewhat unrepresentative of the population since not all fish may be large enough to catch the bait.
- b. This is a parameter, since the college would have access to data on all students (the population)
- 10.2. a. Systematic
 b. Stratified
 c. Voluntary response
 d. Simple random
 e. Cluster
- 10.3. a. Response bias – historically, men are likely to over-report, and women are likely to under-report to this question.
 b. Voluntary response bias – the sample is self-selected
 c. Sampling bias – the sample may not be representative of the whole class
 d. Lack of anonymity
 e. Self-interest study
 f. Loaded question
- 10.4. a. Observational study
 b. Experiment; the treatment is the jumping jacks
 c. Experiment; the treatment is coffee
- 10.5. a. Categorical. b. Quantitative c. Quantitative

10.6A.

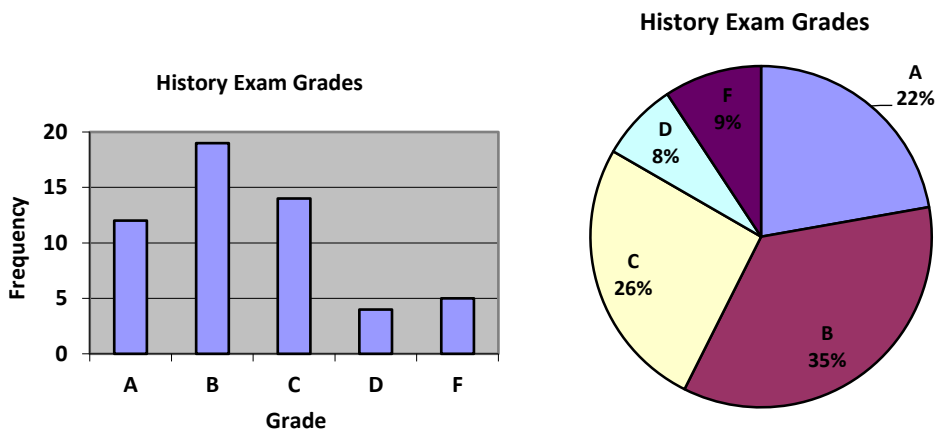

10.6B. $\$2400(.23) = \552

10.6C. While the pie chart accurately depicts the relative size of the people agreeing with each candidate, the chart is confusing, since usually percentages on a pie chart represent the percentage of the pie that the slice represents.

10.7. Answers vary

Chapter 10 – Practice Problems

1. A political scientist surveys 28 of the current 106 representatives in a state's congress. Of them, 14 said they were supporting a new education bill, 12 said there were not supporting the bill, and 2 were undecided.
 - a. What is the population of this survey?
 - b. What is the size of the population?
 - c. What is the size of the sample?
 - d. Give the sample statistic for the proportion of voters surveyed who said they were supporting the education bill.

2. The city of Raleigh has 9500 registered voters. There are two candidates for city council in an upcoming election: Brown and Feliz. The day before the election, a telephone poll of 350 randomly selected registered voters was conducted. 112 said they'd vote for Brown, 207 said they'd vote for Feliz, and 31 were undecided.
 - a. What is the population of this survey?
 - b. What is the size of the population?
 - c. What is the size of the sample?
 - d. Give the sample statistic for the proportion of voters surveyed who said they'd vote for Brown.

3. Studies are often done by pharmaceutical companies to determine the effectiveness of a treatment program. Suppose that a new AIDS antibody drug is currently under study. It is given to patients once the AIDS symptoms have revealed themselves. Of interest is the average (mean) length of time in months patients live once they start the treatment. A researcher follows 40 patients with AIDS from the start of treatment until their deaths.
 - a. What is the population of interest?
 - b. What is the sample?
 - c. What is the parameter of interest?
 - d. What is the statistic?

4. A study was done to determine the age, number of times per week, and the duration (amount of time) of residents using a local park in San Antonio, Texas. The first house in the neighborhood around the park was selected randomly, and then the resident of every eighth house in the neighborhood around the park was interviewed.
 - a) The sampling method was
 - a. simple random; b. systematic; c. stratified; d. cluster
 - b) “Duration (amount of time)” is what type of data?
 - a. qualitative; b. quantitative
 - c) The colors of the houses around the park are what kind of data?
 - a. qualitative; b. quantitative
 - d) The population is _____

5. In a study, the sample is chosen by separating all cars by size, and selecting 10 of each size grouping. What is the sampling method?
6. In a study, the sample is chosen by writing everyone's name on a playing card, shuffling the deck, then choosing the top 20 cards. What is the sampling method?
7. Suppose a researcher conducted a survey by randomly choosing one state in the nation and then randomly picking 100 patients from that state. What sampling method would that researcher have used?
8. Suppose that the second researcher conducted a survey by choosing 100 patients he knew. What sampling method would that researcher have used?
9. The instructor takes her sample by gathering data on five randomly selected students from each Lake Tahoe Community College math class. The type of sampling she used is
 - a. cluster sampling
 - b. stratified sampling
 - c. simple random sampling
 - d. convenience sampling
10. Name the sampling method used in each of the following situations:
 - a. A woman in the airport is handing out questionnaires to travelers asking them to evaluate the airport's service. She does not ask travelers who are hurrying through the airport with their hands full of luggage, but instead asks all travelers who are sitting near gates and not taking naps while they wait.
 - b. A teacher wants to know if her students are doing homework, so she randomly selects rows two and five and then calls on all students in row two and all students in row five to present the solutions to homework problems to the class.
 - c. The marketing manager for an electronics chain store wants information about the ages of its customers. Over the next two weeks, at each store location, 100 randomly selected customers are given questionnaires to fill out asking for information about age, as well as about other variables of interest.
 - d. The librarian at a public library wants to determine what proportion of the library users are children. The librarian has a tally sheet on which she marks whether books are checked out by an adult or a child. She records this data for every fourth patron who checks out books.

- e. A political party wants to know the reaction of voters to a debate between the candidates. The day after the debate, the party's polling staff calls 1,200 randomly selected phone numbers. If a registered voter answers the phone or is available to come to the phone, that registered voter is asked whom he or she intends to vote for and whether the debate changed his or her opinion of the candidates.
11. Identify the most relevant source of bias in this situation: A survey asks the following: Should the mall prohibit loud and annoying rock music in clothing stores catering to teenagers?
 12. Identify the most relevant source of bias in this situation: To determine opinions on voter support for a downtown renovation project, a surveyor randomly questions people working in downtown businesses.
 13. Identify the most relevant source of bias in this situation: A survey asks people to report their actual income and the income they reported on their IRS tax form.
 14. Identify the most relevant source of bias in this situation: A survey randomly calls people from the phone book and asks them to answer a long series of questions.
 15. Identify the most relevant source of bias in this situation: A survey asks the following: Should the death penalty be permitted if innocent people might die?
 16. Identify the most relevant source of bias in this situation: A study seeks to investigate whether a new pain medication is safe to market to the public. They test by randomly selecting 300 men from a set of volunteers.
 17. Does this describe an observational study or an experiment: The temperature on randomly selected days throughout the year was measured.
 18. Does this describe an observational study or an experiment? A group of students are told to listen to music while taking a test and their results are compared to a group not listening to music.
 19. A teacher wishes to know whether the males in his/her class have more conservative attitudes than the females. A questionnaire is distributed assessing attitudes. Is this an observational study or an experiment?
 20. A study is conducted to determine whether people learn better with spaced or massed practice. Subjects volunteer from an introductory psychology class. At the beginning of the semester 12 subjects volunteer and are assigned to the massed-practice group. At the end of the semester 12 subjects volunteer and are assigned to the spaced-practice condition. Is this an observational study or an experiment?

21. A team of researchers is testing the effectiveness of a new HPV vaccine. They randomly divide the subjects into two groups. Group 1 receives new HPV vaccine, and Group 2 receives the existing HPV vaccine. The patients in the study do not know which group they are in.
 - a. Which is the treatment group?
 - b. Which is the control group (if there is one)?
 - c. Is this study blind, double-blind, or neither?
 - d. Is this best described as an experiment, a controlled experiment, or a placebo controlled experiment?

22. For the clinical trials of a weight loss drug containing *Garcinia cambogia* the subjects were randomly divided into two groups. The first received an inert pill along with an exercise and diet plan, while the second received the test medicine along with the same exercise and diet plan. The patients do not know which group they are in, nor do the fitness and nutrition advisors.
 - a. Which is the treatment group?
 - b. Which is the control group (if there is one)?
 - c. Is this study blind, double-blind, or neither?
 - d. Is this best described as an experiment, a controlled experiment, or a placebo controlled experiment?

23. In a study, you ask the subjects their age in years. Is this data qualitative or quantitative?

24. In a study, you ask the subjects their gender. Is this data qualitative or quantitative?

25. In a study, you determine the account number for a sample of customers. Is this data qualitative or quantitative?

26. In a study, you count the number of eggs laid by each chicken for a sample of chickens. Is this data qualitative or quantitative?

27. In a study, you measure the head circumference for a sample of 2 year old children. Is this data qualitative or quantitative?

28. In a study, you record the gas mileage for a sample of vehicles. Is this data qualitative or quantitative?

29. For the following exercises, identify the type of data that would be used to describe a response (quantitative or qualitative), and give an example of the data.
 - a) number of tickets sold to a concert
 - b) percent of body fat
 - c) favorite baseball team
 - d) time in line to buy groceries
 - e) number of students enrolled at Scottsdale Community College

- f) most-watched television show
- g) brand of toothpaste
- h) distance to the closest movie theatre
- i) age of executives in Fortune 500 companies
- j) number of competing computer spreadsheet software packages

30. The data below shows the favorite sport for a sample of 20 college freshmen.

Football	Soccer	Baseball	Cheerleading	Basketball	Swimming
5	4	4	2	4	1

- a. Given the frequencies above, draw a relative-frequency table for the data.
 - b. Construct a bar graph of the data.
 - c. Construct a Pareto Chart of the data.
 - d. Draw a pie chart of the data.
31. The data below shows the type of pet(s) owned by a sample of individuals.

Dog Dog Dog Cat Bird Cat Turtle Dog Cat Cat Bird Hamster
 Fish Bird Dog Dog Cat Turtle Hamster Dog Cat Dog Dog
 Bird

- a. Construct a relative-frequency table for the type of pet.
 - b. Construct a bar graph of the data.
 - c. Construct a pie chart of the data.
32. The number of clear days in a year for several U.S. cities are provided in the table below. Construct a bar graph of the data.

City	Clear Days
Phoenix, Arizona	211
Denver, Colorado	115
Nashville, Tennessee	102
Tampa, Florida	101
Washington, DC	96
Chicago, Illinois	84
Cleveland, Ohio	66
Rochester, New York	61
Seattle, Washington	58

33. The bar graph below shows the *percentage* of students who received each letter grade on their last English paper. The class contains 20 students. What number of students earned an A on their paper?

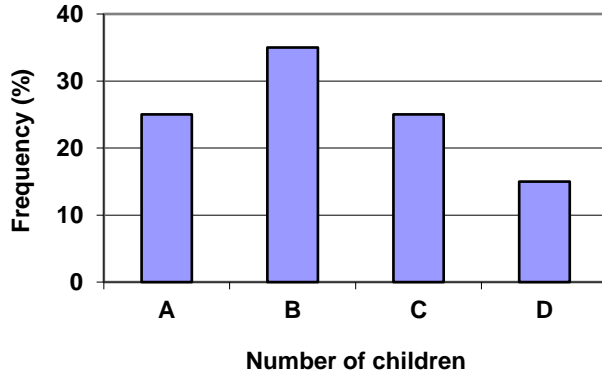

34. Kori categorized her spending for this month into four categories: Rent, Food, Fun, and Other. The percentages she spent in each category are pictured here. If she spent a total of \$2600 this month, how much did she spend on rent?

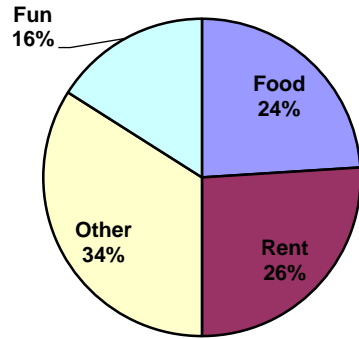

35. A graph appears below showing the number of adults and children who prefer each type of soda. There were 130 adults and kids surveyed. Discuss some ways in which the graph below could be improved.

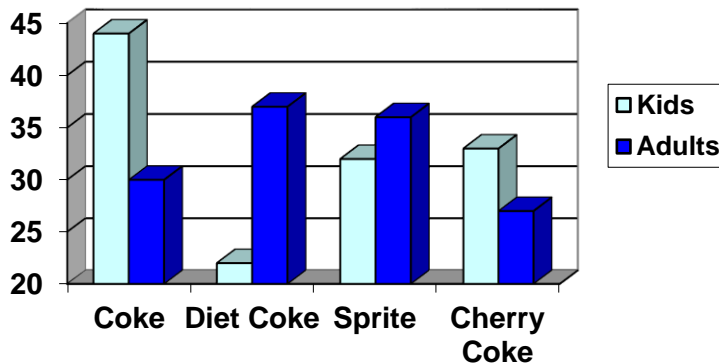

36. The table below shows scores on a Math test.

80	50	50	90	70	70	100	60	70	80	70	50
90	100	80	70	30	80	80	70	100	60	60	50

- a. Create a frequency table for the Math test scores.
- b. Construct a histogram of the data.

37. A group of adults were asked how many cars they had in their household.

1	4	2	2	1	2	3	3	1	4	2	2
1	2	1	3	2	2	1	2	1	1	1	2

- a. Create a relative-frequency table for the car number data.
- b. Construct a histogram of the data.

38. A group of adults were asked how many children they have in their families. The graph below shows the number of adults who indicated each number of children.

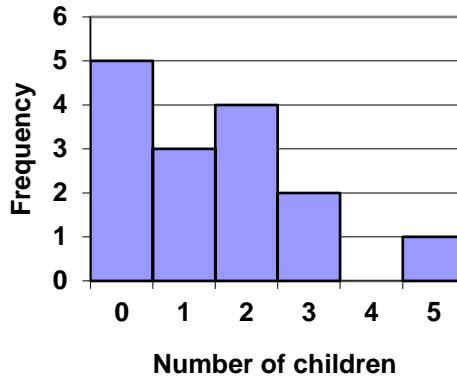

- a. How many adults were questioned?
- b. What percentage of the adults questioned had 0 children?

39. Jasmine was interested in how many days it would take an order from Amazon to arrive at her door. The graph below shows the data she collected.



- How many orders did she make?
- What percentage of the orders arrived in one day?

Chapter 11 – Describing Data

Chapter 11 Learning Objectives:

- Identify distribution shapes from histograms
- Calculate and interpret the mean, median, and mode
- Compute and interpret the range and standard deviation
- Calculate and interpret the quartiles, 5 number summary, and boxplots

Section 11.1 – Describing a Distribution

Section 11.2 – Measures of Central Tendency

Section 11.3 – Measures of Variation

Section 11.4 – Quartiles, Five Number Summary, and Boxplots

Section 11.1 – Describing a Distribution

We will now begin to discuss how to describe a particular variable of interest. Of particular importance is the variable's distribution.

Distribution

The **distribution** of a variable tells you all possible values the variable can take on, and the frequency that each of the possible values occurs.

In the last chapter, we looked at frequency tables and histograms, which are two ways of showing a variable's distribution. Distributions can also be shown by fitting smooth curves to a graphical display of a data set, or using a formula.

In statistics, when we consider differences between distributions, we usually look at several characteristics of the distribution:

Shape
Outliers
Center
Spread

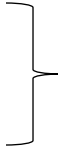

Together we refer to these as the “SOCS” of the distribution

Distribution Shapes

The shape of a distribution is frequently estimated by drawing a smooth curve to a histogram, as shown in the following diagram:

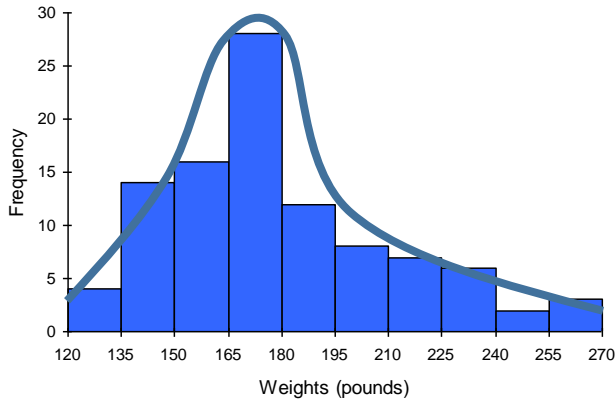

In the histogram to the left, a smooth curve has been drawn to roughly approximate the shape of the distribution for the variable “Weights”.

This particular distribution is right-skewed.

The previous example showed just one of the many possible distribution shapes that can be observed. There are several common distribution shapes, each with unique combinations of number of peaks, symmetry, center, and spread.

The most commonly used distribution curve in elementary statistics is a bell-shaped distribution curve, but it is important to realize that there are many possible distribution shapes. Some are symmetric, some are right-skewed, left-skewed, unimodal (one peak), or bimodal (two peaks). A few of the most common shapes are shown below.

Symmetric distribution

A **symmetric distribution** is a distribution shape in which the left and right sides of the distribution are roughly mirror images of one another.

Symmetric Distribution Shapes:

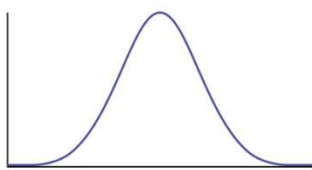

Bell shaped

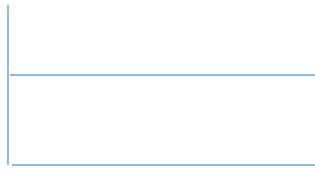

Uniform

Skewed distribution

A **skewed distribution** is a distribution shape in which the data is asymmetrical, and tends to cluster toward one side, while having a longer “tail” on the other side.

Skewed Distribution Shapes:

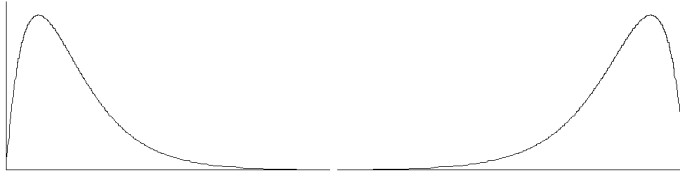

Right-skewed
(tail extends to right)

Left-skewed
(tail extends to left)

Note: In practice, there will be variables whose distribution shapes do not exactly fit any of the shapes described above.

Example 1

The histogram below shows the “Model Year” for a sample of 40 vehicles.

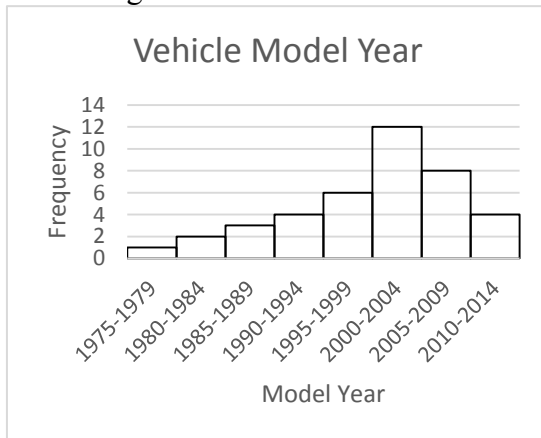

- a) Is the distribution symmetric or skewed?
- b) Classify the shape of the distribution as bell shaped, uniform, right-skewed, or left-skewed.

-
- a) The distribution is a skewed distribution, as the data clusters on the right side and has a longer tail on the left side.
 - b) This distribution is left-skewed, as the longer tail extends to the left.

Example 2

Given the histogram below:

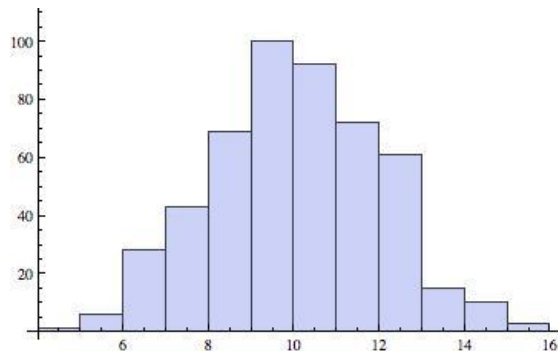

- Is the distribution symmetric or skewed?
- Classify the shape of the distribution as bell shaped, uniform, right-skewed, or left-skewed.

- The distribution is a symmetric distribution, as the data clusters fairly evenly on both the left and right sides.
- This distribution is bell-shaped.

Outliers

We will only briefly touch on outliers in this text.

Outlier

An **outlier** is a data value that is “extreme” when compared to the rest of the values in the data set.

It may be extreme in either direction, meaning it may be very small when compared to the rest of the values in the data set, or it may be very large when compared to the rest of the values in the data set.

While there are several formal methods for determining if a data value is an outlier (or a potential outlier), the determination of outliers can be somewhat subjective. This means that it can be left up to the researcher to determine which observations are “extreme”.

Example 3

Consider the data set below which consists of “Exam Scores” for a sample of 20 Statistics students:

89	73	76	95	72	61	70	18	65	57
77	93	85	81	72	48	69	75	83	70

Do there appear to be any outliers in the data set? Why or why not?

It can be difficult to look at a list of data and try to identify any “extreme” or unusual values. These outliers are easier to identify by looking at a graph of the data.

Create a histogram, and look for any outliers. They will be values that appear to fall far outside the normal values.

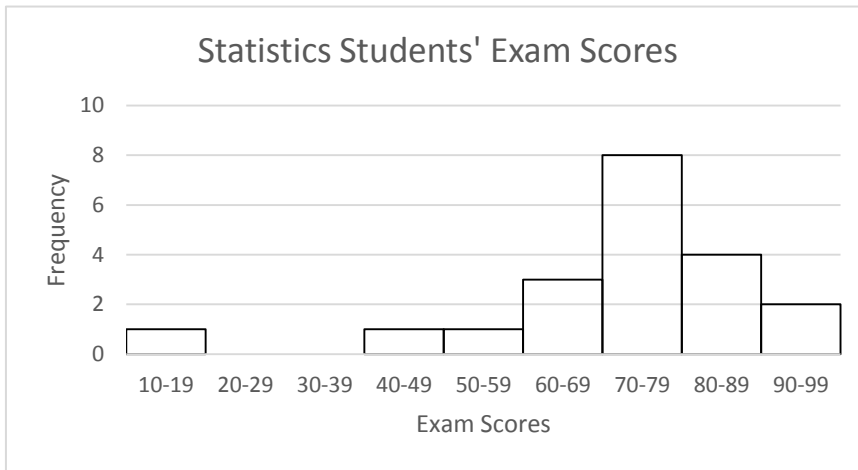

Notice the graph shows one bar that is “far” below the other bars in the graph. When looking more closely, we see that this bar represents 1 test score. If we look back at the data set, we can see this bar represents 1 student who scored an 18 on the Exam.

The value 18 appears to be an outlier, because it is “far” outside the original group of data values. It is important to recognize that there is an outlier in the data set, as the outlier may affect the descriptive measures of the mean and standard deviation (coming up in the next sections).

Since outliers can affect the descriptive measures we use to describe a data set (specifically the mean as a measure of center and the standard deviation as a measure of spread), it is important to visually inspect a data set to see if there appear to be any outliers. We will come back to this idea in the next several sections.

Recall, we started this chapter by defining a distribution, and describing the “SOCS” (Shape, Outliers, Center, and Spread) of a distribution. Now that we have spent time

introducing the “Shape” of a distribution, and briefly discussing “Outliers”, we will move on to measuring the “Center”. We will discuss “Spread” later on in Sections 11.3 and 11.4.

Section 11.2 – Measures of Central Tendency

The “Center” is an important aspect of a distribution. When we refer to the “Center” we are trying to get an idea of the location of the middle of the data set. There are three common measures of central tendency. They are the mean, median, and mode.

Let's begin by trying to find the most "typical" value of a data set.

Note that we just used the word "typical" although in many cases you might think of using the word "average." We need to be careful with the word "average" as it means different things to different people in different contexts. One of the most common uses of the word "average" is what mathematicians and statisticians call the **arithmetic mean**, or just plain old **mean** for short. "Arithmetic mean" sounds rather fancy, but you have likely calculated a mean many times without realizing it; the mean is what most people think of when they use the word "average".

Mean

The **mean** of a set of data is the sum of the data values divided by the number of values.

Example 4

Marci's exam scores for her last math class were: 79, 86, 82, 94. The mean of these values would be:

$$\frac{79 + 86 + 82 + 94}{4} = 85.25$$

Typically we round means to one more decimal place than the original data had. In this case, we would round 85.25 to 85.3.

Example 5

The number of touchdown (TD) passes thrown by each of the 31 teams in the National Football League in the 2000 season are shown below.

37 33 33 32 29 28 28 23 22 22 22 21 21 21 20
20 19 19 18 18 18 18 16 15 14 14 14 12 12 9 6

Adding these values, we get 634 total TDs. Dividing by 31, the number of data values, we get $634/31 = 20.4516$. It would be appropriate to round this to 20.5.

It would be most correct for us to report that “The mean number of touchdown passes thrown in the NFL in the 2000 season was 20.5 passes,” but it is not uncommon to see the more casual word “average” used in place of “mean.”

You Try 11.2A

The price of a jar of peanut butter at 5 stores was: \$3.29, \$3.59, \$3.79, \$3.75, and \$3.99. Find the mean price.

Example 6

The one hundred families in a particular neighborhood are asked their annual household income, to the nearest \$5 thousand dollars. The results are summarized in a frequency table below.

Income (thousands of dollars)	Frequency
15	6
20	8
25	11
30	17
35	19
40	20
45	12
50	7

Calculating the mean by hand could get tricky if we try to type in all 100 values:

$$\frac{\overbrace{15 + \cdots + 15}^{6 \text{ terms}} + \overbrace{20 + \cdots + 20}^{8 \text{ terms}} + \overbrace{25 + \cdots + 25}^{11 \text{ terms}} + \cdots}{100}$$

We could calculate this more easily by noticing that adding 15 to itself six times is the same as $15 \cdot 6 = 90$. Using this simplification, we get

$$\frac{15 \cdot 6 + 20 \cdot 8 + 25 \cdot 11 + 30 \cdot 17 + 35 \cdot 19 + 40 \cdot 20 + 45 \cdot 12 + 50 \cdot 7}{100} = \frac{3390}{100} = 33.9$$

The mean household income of our sample is 33.9 thousand dollars (\$33,900).

Example 7

Extending off the last example, suppose a new family moves into the neighborhood example that has a household income of \$5 million (\$5000 thousand). Adding this to our sample, our mean is now:

$$\frac{15 \cdot 6 + 20 \cdot 8 + 25 \cdot 11 + 30 \cdot 17 + 35 \cdot 19 + 40 \cdot 20 + 45 \cdot 12 + 50 \cdot 7 + 5000 \cdot 1}{101} = \frac{8390}{101} = 83.069$$

While 83.1 thousand dollars (\$83,069) is the correct mean household income, it no longer represents a “typical” value.

Imagine the data values on a see-saw or balance scale. The mean is the value that keeps the data in balance, like in the picture below.

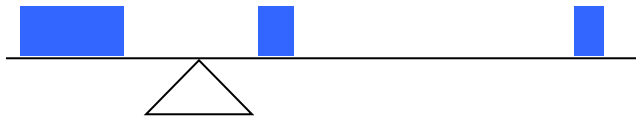

If we graph our household data, the \$5 million data value is so far out to the right that the mean has to adjust up to keep things in balance

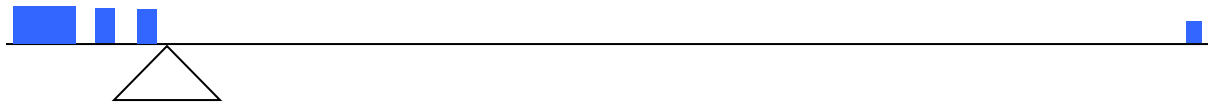

For this reason, when working with data that have **outliers** – as described in the previous section - it is common to use a different measure of center, the **median**.

Median

The **median** of a set of data is the value in the middle when the data is in order

To find the median, *begin by listing the data in order from smallest to largest.*

If the number of data values, n , is odd, then the median is the middle data value. This position in the ordered list of this value can be found by rounding $n/2$ up to the next whole number.

If the number of data values is even, there is no one middle value, so we find the mean of the two middle values. The two middle numbers will be in the $n/2$ and the $(n/2) + 1$ positions in the ordered list.

Example 8

Returning to the football touchdown data, we would start by listing the data in order from smallest to largest.

6 9 12 12 14 14 14 15 16 18 18 18 18 19 19 20
20 21 21 21 22 22 22 23 28 28 29 32 33 33 37

Since there are 31 data values, an odd number, the median will be the middle number, the 16th data value ($31/2 = 15.5$, round up to 16, leaving 15 values below and 15 above). The 16th data value is 20, so the median number of touchdown passes in the 2000 season was 20 passes. Notice that for this data, the median is fairly close to the mean we calculated earlier, 20.5.

Example 9

Find the median of these quiz scores: 15 20 18 16 14 18 12 15 17 17

We start by listing the data in order: 12 14 15 15 16 17 17 18 18 20

Since there are 10 data values, an even number, there is no one middle number. The median will be the mean of the numbers in positions $n/2$ and $(n/2) + 1$. Since $n = 10$, $n/2 = 5$ and $(n/2) + 1 = 6$, so we need the mean of the 5th and 6th numbers in the ordered list.

The 5th number in the ordered list is 16, and the 6th number in the ordered list is 17. So we find the mean of the two middle numbers, 16 and 17, and get $(16+17)/2 = 16.5$.

The median quiz score was 16.5.

You Try 11.2B

The price of a jar of peanut butter at 5 stores was: \$3.29, \$3.59, \$3.79, \$3.75, and \$3.99. Find the median price.

Example 10

Let us return now to our original household income data

Income (thousands of dollars)	Frequency
15	6
20	8
25	11
30	17
35	19
40	20
45	12
50	7

Here we have 100 data values. If we didn't already know that, we could find it by adding the frequencies. Since 100 is an even number, we need to find the mean of the middle two data values - the 50th and 51st data values. To find these, we start counting up from the bottom:

There are 6 data values of \$15, so →	Values 1 to 6 are \$15 thousand
The next 8 data values are \$20, so →	Values 7 to (6+8)=14 are \$20 thousand
The next 11 data values are \$25, so →	Values 15 to (14+11)=25 are \$25 thousand
The next 17 data values are \$30, so →	Values 26 to (25+17)=42 are \$30 thousand
The next 19 data values are \$35, so →	Values 43 to (42+19)=61 are \$35 thousand

From this we can tell that values 50 and 51 will be \$35 thousand, and the mean of these two values is \$35 thousand. The median income in this neighborhood is \$35 thousand.

Example 11

If we add in the new neighbor with a \$5 million household income, then there will be 101 data values, and the 51st value will be the median. As we discovered in the last example, the 51st value is \$35 thousand. Notice that the new neighbor did not affect the median in this case. The median is not swayed as much by outliers as the mean is.

In addition to the mean and the median, there is one other common measurement of the "typical" value of a data set: the **mode**.

Mode

The **mode** is the element of the data set that occurs most frequently.

The mode is fairly useless with data like weights or heights where there are a large number of possible values. The mode is most commonly used for categorical data, for which median and mean cannot be computed.

Example 12

In our vehicle color survey, we collected the data

Color	Frequency
Blue	3
Green	5
Red	4
White	3
Black	2
Grey	3

For this data, Green is the mode, since it is the data value that occurred the most frequently.

It is possible for a data set to have more than one mode if several categories have the same frequency, or no modes if each every category occurs only once.

You Try 11.2C

Reviewers were asked to rate a product on a scale of 1 to 5. Find

- a. The mean rating
- b. The median rating
- c. The mode rating

Rating	Frequency
1	4
2	8
3	7
4	3
5	1

Section 11.3 – Measures of Variation

Another component of describing a data set is how much “Spread” there is in the data set. In other words, how much the data in the distribution vary from one another. It may seem like once we know the center of a data set, we know everything there is to know. The first example will demonstrate why we need measures of variation (or spread).

There are several ways to measure this "Spread" of the data. The three most common measures are the range, standard deviation, and quartiles. In this section we will learn about the range and standard deviation. We will discuss quartiles in the following section.

We will focus first on the simplest measure of spread, called the **range**.

Range

The range is the difference between the maximum value and the minimum value of the data set.

Example 13

Consider these three sets of quiz scores:

Section A: 5 5 5 5 5 5 5 5 5

Section B: 0 0 0 0 0 10 10 10 10 10

Section C: 4 4 4 5 5 5 5 6 6 6

All three of these sets of data have a mean of 5 and median of 5. If we only calculated a measure of center for each set of scores, we would say the three sets are all identical, yet the sets of scores are clearly quite different. Calculating a measure of variability (or spread) will help identify how they are different.

For section A, the range is 0 since both maximum and minimum are 5 and $5 - 5 = 0$

For section B, the range is 10 since $10 - 0 = 10$

For section C, the range is 2 since $6 - 4 = 2$

You Try 11.3A

The price of a jar of peanut butter at 5 stores was: \$3.29, \$3.59, \$3.79, \$3.75, and \$3.99. Find the range of the prices.

In example 21, the range seems to be revealing how spread out the data is. However, suppose we add a fourth section, Section D,.

This section also has a mean and median of 5. The range is 10, yet this data set is quite different than Section B. To better illuminate the differences, we'll have to turn to more sophisticated measures of variation.

Standard Deviation

The standard deviation is a measure of variation based on measuring how far, on average, each data value deviates, or is different, from the mean. A few important characteristics:

- Standard deviation is always positive. Standard deviation will be zero if all the data values are equal, and will get larger as the data spreads out.
- Standard deviation has the same units as the original data.
- Standard deviation, like the mean, can be highly influenced by outliers.

Using the data from Section D: 0 5 5 5 5 5 5 5 10, we could compute for each data value the difference between the data value and the mean. This will give us an idea of “how far” each value in the data set lies away from the mean.

data value	deviation: data value - mean
0	$0-5 = -5$
5	$5-5 = 0$
5	$5-5 = 0$
5	$5-5 = 0$
5	$5-5 = 0$
5	$5-5 = 0$
5	$5-5 = 0$
5	$5-5 = 0$
5	$5-5 = 0$
10	$10-5 = 5$

We would like to get an idea of the "average" deviation from the mean, but if we find the average of the values in the second column the negative and positive values cancel each other out (this always happens), so instead we square every value in the second column:

data value	deviation: data value - mean	deviation squared
0	$0-5 = -5$	$(-5)^2 = 25$
5	$5-5 = 0$	$0^2 = 0$
5	$5-5 = 0$	$0^2 = 0$
5	$5-5 = 0$	$0^2 = 0$
5	$5-5 = 0$	$0^2 = 0$
5	$5-5 = 0$	$0^2 = 0$
5	$5-5 = 0$	$0^2 = 0$
5	$5-5 = 0$	$0^2 = 0$
5	$5-5 = 0$	$0^2 = 0$
10	$10-5 = 5$	$(5)^2 = 25$

We then add the squared deviations up to get $25 + 0 + 0 + 0 + 0 + 0 + 0 + 0 + 0 + 25 = 50$. Ordinarily we would then divide by the number of scores, n , (in this case, 10) to find the mean of the deviations. But we only do this if the data set represents a population; if the data set represents a sample (as it almost always does), we instead divide by $n - 1$ (in this case, $10 - 1 = 9$).¹⁵

So in our example, we would have $50/10 = 5$ if section D represents a population and $50/9 =$ about 5.56 if section D represents a sample. These values (5 and 5.56) are called, respectively, the **population variance** and the **sample variance** for section D.

Variance can be a useful statistical concept, but note that the units of variance in this instance would be points-squared since we squared all of the deviations. What are

¹⁵ The reason we do this is highly technical, but we can see how it might be useful by considering the case of a small sample from a population that contains an outlier, which would increase the average deviation: the outlier very likely won't be included in the sample, so the mean deviation of the sample would underestimate the mean deviation of the population; thus we divide by a slightly smaller number to get a slightly bigger average deviation.

points-squared? Good question. We would rather deal with the units we started with (points in this case), so to convert back we take the square root and get:

$$\text{population standard deviation} = \sqrt{\frac{50}{10}} = \sqrt{5} \approx 2.2$$

or

$$\text{sample standard deviation} = \sqrt{\frac{50}{9}} \approx 2.4$$

If we are unsure whether the data set is a sample or a population, we will usually assume it is a sample, and we will round answers to one more decimal place than the original data, as we have done above.

To Compute Standard Deviation

To Compute Standard Deviation:

1. Find the deviation of each data from the mean. In other words, subtract the mean from the data value.
2. Square each deviation.
3. Add the squared deviations.
4. Divide by n , the number of data values, if the data represents a whole population; divide by $n - 1$ if the data is from a sample.
5. Compute the square root of the result.

Example 14

Computing the standard deviation for Section B above, we first calculate that the mean is 5. Using a table can help keep track of your computations for the standard deviation:

data value	deviation: data value - mean	deviation squared
0	$0-5 = -5$	$(-5)^2 = 25$
0	$0-5 = -5$	$(-5)^2 = 25$
0	$0-5 = -5$	$(-5)^2 = 25$
0	$0-5 = -5$	$(-5)^2 = 25$
0	$0-5 = -5$	$(-5)^2 = 25$
10	$10-5 = 5$	$(5)^2 = 25$
10	$10-5 = 5$	$(5)^2 = 25$
10	$10-5 = 5$	$(5)^2 = 25$
10	$10-5 = 5$	$(5)^2 = 25$
10	$10-5 = 5$	$(5)^2 = 25$

Assuming this data represents a population, we will add the squared deviations, divide by 10, the number of data values, and compute the square root:

$$\sqrt{\frac{25+25+25+25+25+25+25+25+25+25}{10}} = \sqrt{\frac{250}{10}} = 5$$

Notice that the standard deviation of this data set is much larger than that of section D since the data in this set is more spread out.

For comparison, the standard deviations of all four sections are:

Section A: 5 5 5 5 5 5 5 5 5 5	Standard deviation: 0
Section B: 0 0 0 0 0 10 10 10 10 10	Standard deviation: 5
Section C: 4 4 4 5 5 5 5 6 6 6	Standard deviation: 0.8
Section D: 0 5 5 5 5 5 5 5 10	Standard deviation: 2.2

You Try 11.3B

The price of a jar of peanut butter at 5 stores were: \$3.29, \$3.59, \$3.79, \$3.75, and \$3.99. Find the standard deviation of the prices.

SEE THE END OF THE NEXT SECTION FOR INSTRUCTIONS ON FINDING SUMMARY STATISTICS USING THE TI-83/84 CALCULATOR.

Section 11.4 – Quartiles, Five Number Summary, and Boxplots

The final measure of variability we must consider are the quartiles. Whereas the standard deviation was a measure of spread based around the mean, the quartiles are a measure of spread based around the median.

Quartiles

Quartiles are values that divide the data into quarters.

The first quartile (Q_1) is the value so that 25% of the data values are below it; the third quartile (Q_3) is the value so that 75% of the data values are below it. You may have guessed that the second quartile (Q_2) is the same as the median, since the median is the value so that 50% of the data values are below it.

This divides the data into quarters; 25% of the data is between the minimum and Q_1 , 25% is between Q_1 and Q_2 (the median), 25% is between Q_2 and Q_3 , and 25% is between Q_3 and the maximum value.

While quartiles are not a 1-number summary of variation like the range, the quartiles are used with the median, minimum, and maximum values to form a **5 number summary** of the data.

Five Number Summary

The five number summary takes this form:

Minimum, Q_1 , Median (Q_2), Q_3 , Maximum

To find the first quartile, we need to find the data value so that 25% of the data is below it. If n is the number of data values, we compute a locator by finding 25% of n . If this locator is a decimal value, we round up, and find the data value in that position. If the locator is a whole number, we find the mean of the data value in that position and the next data value. This is identical to the process we used to find the median, except we use 25% of the data values rather than half the data values as the locator.

To find the first quartile, Q_1

Begin by ordering the data from smallest to largest

Compute the locator: $L = 0.25n$

If L is a decimal value:

Round up to $L+$

Use the data value in the $L+^{\text{th}}$ position

If L is a whole number:

Find the mean of the data values in the L^{th} and $L+1^{\text{th}}$ positions.

To find the third quartile, Q_3

Use the same procedure as for Q_1 , but with locator: $L = 0.75n$

Example 15

Suppose we have measured 9 females and their heights (in inches), sorted from smallest to largest are: 59 60 62 64 66 67 69 70 72. Give the five-number summary for this data set.

The 5-number summary gives the minimum value, Q_1 , the median (Q_2), Q_3 , and the maximum value.

For this sample, the minimum value is 59, and the maximum is 72.

To find the **first quartile** we first compute the locator: 25% of 9 is $L = 0.25(9) = 2.25$. Since this value is not a whole number, we round up to 3. The first quartile will be the third data value: 62 inches.

To find the **second quartile, the median**, we compute the locator: 50% of 9 is $0.50(9) = 4.5$. Since this value is not a whole number, we round up to 5. The second quartile (median) will be the fifth data value: 66 inches.

To find the **third quartile**, we again compute the locator: 75% of 9 is $0.75(9) = 6.75$. Since this value is not a whole number, we round up to 7. The third quartile will be the seventh data value: 69 inches.

The 5 number summary is: 59, 62, 66, 69, 72.

Example 16

Suppose we had measured 8 females and their heights (in inches), sorted from smallest to largest are: 59 60 62 64 66 67 69 70 Give the five-number summary for this data set.

For this sample, the minimum value is 59, and the maximum is 70.

To find the **first quartile** we first compute the locator: 25% of 8 is $L = 0.25(8) = 2$. Since this value *is* a whole number, we will find the mean of the 2nd and 3rd data values: $(60+62)/2 = 61$, so the first quartile $Q_1 = 61$ inches.

To find the **second quartile, the median**, we compute the locator: 50% of 8 is $0.50(8) = 4$. Since this value *is* a whole number, we will find the mean of the 4th and 5th data values: $(64+66)/2 = 65$. The second quartile (median) $Q_2 = 65$ inches.

The **third quartile** is computed similarly, using 75% instead of 25%. $L = 0.75(8) = 6$. This is a whole number, so we will find the mean of the 6th and 7th data values: $(67+69)/2 = 68$, so $Q_3 = 68$ inches.

The 5 number summary for this data set would be: 59, 61, 65, 68, 70.

Example 17

Returning to our quiz score data. In each case, the first quartile locator is $0.25(10) = 2.5$, so the first quartile will be the 3rd data value, and the third quartile will be the 8th data value. Creating the five-number summaries:

Section and data	5-number summary
Section A: 5 5 5 5 5 5 5 5 5	5, 5, 5, 5, 5
Section B: 0 0 0 0 10 10 10 10 10	0, 0, 5, 10, 10
Section C: 4 4 4 5 5 5 6 6 6	4, 4, 5, 6, 6
Section D: 0 5 5 5 5 5 5 5 10	0, 5, 5, 5, 10

Of course, with a relatively small data set, finding a five-number summary is a bit silly, since the summary contains almost as many values as the original data.

Example 18

Suppose we had measured 8 females and their heights (in inches), sorted from smallest to largest are: 59 60 62 64 66 67 69 70. Give the five-number summary for this data set.

For this sample, the minimum value is 59, and the maximum is 70.

To find the **first quartile** we first compute the locator: 25% of 8 is $L = 0.25(8) = 2$. Since this value *is* a whole number, we will find the mean of the 2nd and 3rd data values: $(60+62)/2 = 61$, so the first quartile $Q_1 = 61$ inches.

To find the **second quartile, the median**, we compute the locator: 50% of 8 is $0.50(8) = 4$. Since this value *is* a whole number, we will find the mean of the 4th and 5th data values: $(64+66)/2 = 65$. The second quartile (median) $Q_2 = 65$ inches.

The **third quartile** is computed similarly, using 75% instead of 25%. $L = 0.75(8) = 6$. This is a whole number, so we will find the mean of the 6th and 7th data values: $(67+69)/2 = 68$, so $Q_3 = 68$ inches.

The 5 number summary for this data set would be: 59, 61, 65, 68, 70.

You Try 11.4A

The total cost of textbooks for the term was collected from 36 students. Find the 5 number summary of this data.

\$140	\$160	\$160	\$165	\$180	\$220	\$235	\$240	\$250	\$260	\$280	\$285
\$285	\$285	\$290	\$300	\$300	\$305	\$310	\$310	\$315	\$315	\$320	\$320
\$330	\$340	\$345	\$350	\$355	\$360	\$360	\$380	\$395	\$420	\$460	\$460

Note that the 5 number summary divides the data into four intervals, each of which will contain about 25% of the data.

It is often difficult to picture how the 5 number summary shows the variability in a data set. For visualizing data, there is a graphical representation of the 5-number summary called a **box plot**, or box and whisker graph.

Boxplot (Box and Whisker Plot)

A **boxplot** is a graphical representation of a five-number summary.

To create a box plot, a number line is first drawn. A box is drawn from the first quartile to the third quartile, and a line is drawn through the box at the median. “Whiskers” are extended out to the minimum and maximum values.

NOTE: It is important to use consistent intervals of values on the number line in a boxplot. For example, if you start your number line at 0, you may want to make tick marks at 10, 20, 30, etc. You should never use different intervals on the same axis. For example, do not have your first tick mark at 10, your next at 15, then the next at 35, etc. This will counteract the entire purpose of a boxplot, which is to see how the spread differs within the data set.

Example 19

The box plot below is based on the 9 female height data with 5 number summary: 59, 62, 66, 69, 72.

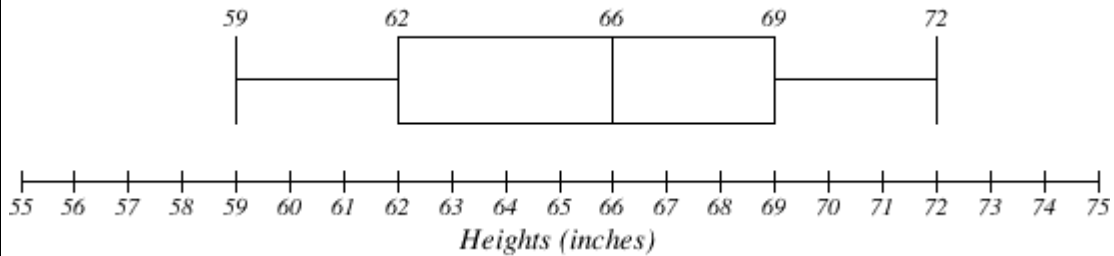

Notice that the horizontal axis used consistently spaced units (increments of 1).

Example 20

The box plot below is based on the household income data with 5 number summary: 15, 27.5, 35, 40, 50

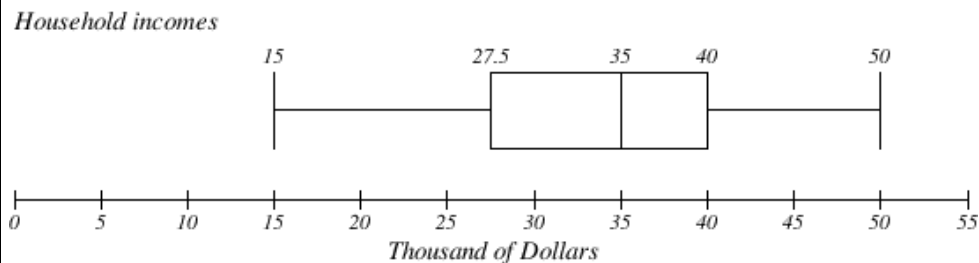

Notice that the horizontal axis used consistently spaced units (increments of 5).

You Try 11.4B

Create a boxplot based on the textbook price data from the last You Try problem.

Box plots are particularly useful for comparing data from two populations.

Example 21

The boxplot below is based on the birth weights of infants with severe idiopathic respiratory distress syndrome (SIRDS)¹⁶. The boxplot is separated to show the birth weights of infants who survived and those that did not.

Survived

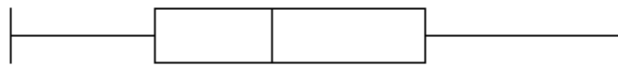

Died

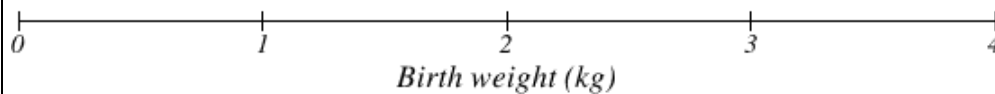

Comparing the two groups, the boxplot reveals that the birth weights of the infants that died appear to be, overall, smaller than the weights of infants that survived. In fact, we can see that the median birth weight of infants that survived is the same as the third quartile of the infants that died.

Similarly, we can see that the first quartile of the survivors is larger than the median weight of those that died, meaning that over 75% of the survivors had a birth weight larger than the median birth weight of those that died.

Looking at the maximum value for those that died and the third quartile of the survivors, we can see that over 25% of the survivors had birth weights higher than the heaviest infant that died.

The box plot gives us a quick, albeit informal, way to determine that birth weight is quite likely linked to survival of infants with SIRDS.

¹⁶ van Vliet, P.K. and Gupta, J.M. (1973) Sodium bicarbonate in idiopathic respiratory distress syndrome. *Arch. Disease in Childhood*, **48**, 249–255. As quoted on <http://openlearn.open.ac.uk/mod/oucontent/view.php?id=398296§ion=1.1.3>

Example 22

The box plot of service times for two fast-food restaurants is shown below.

Store 1

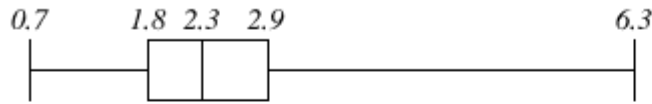

Store 2

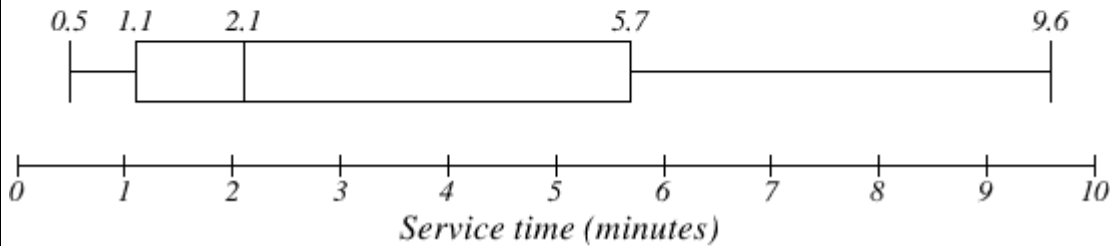

While store 2 had a slightly shorter median service time (2.1 minutes vs. 2.3 minutes), store 2 is less consistent, with a wider spread of the data.

At store 1, 75% of customers were served within 2.9 minutes, while at store 2, 75% of customers were served within 5.7 minutes.

Which store should you go to in a hurry? That depends upon your opinions about luck – 25% of customers at store 2 had to wait between 5.7 and 9.6 minutes.

Percentiles

Percentiles are used in statistics to indicate a value below which a certain **percentage** of the data values fall. For example, if you score in the 60th percentile on a standardized test, it means that 60% of the other scores were lower than yours, (and 40% were higher).

Example 23

- What percentage of the values in a data set lie at or below the 30th percentile?
- What percentage of the values in a data set lie at or above the 30th percentile?
- If 500 measurements were taken, approximately **how many** would be at or below the 30th percentile?
- If 500 measurements were taken, approximately **how many** would be at or above the 30th percentile?

- a) By definition, 30% of the data values lie at or below the 30th percentile.
- b) Since 30% lie below the 30th percentile, $100\% - 30\% = 70\%$ of the data values lie above it.
- c) 30% of $500 = .30(500) = 150$ values lie below the 30th percentile
- d) 70% of $500 = .70(500) = 350$ values lie above the 30th percentile

In general, for any set of numerical data, 50% of the data values are below the median, so the median will always represent the 50th percentile. The lower quartile (Q1) would be the 25th percentile, and the upper quartile (Q3) would be the 75th percentile.

Example 24

In example 26 we looked at the heights (in inches), of a sample of 8 females. The heights were: 59 60 62 64 66 67 69 70, and we found the 5 number summary to be: 59, 61, 65, 68, 70.

- a) What is the 25th percentile of the heights of females?
 - b) What is the 75th percentile of the heights of females?
- a) We know that the 25th percentile is the height such that 25% of heights are lower, and 75% of heights are higher. This is the same as the first quartile. The 25th percentile is 61 inches.
- b) We know that the 75th percentile is the height such that 75% of heights are lower, and 25% of heights are higher. This is the same as the third quartile. The 75th percentile is 68 inches.

In this text, we only examine the process of finding the 25th, 50th, and 75th percentiles. Using other statistical techniques, it is possible to find the data value corresponding to any percentile in the data set.

Calculator Instructions for Finding Summary Statistics Using TI-83/84:

1. Turn on the calculator
2. Press the “STAT” key
3. Hit “Enter” on option 1: “Edit”

This will bring you to a screen that contains lists: L1, L2, L3, etc.

3. Enter the data values (one value per row) into L1. For any negative values you need to use the (-) key, not the subtraction key. Continue until all data is entered into L1.
4. Press the “STAT” key again
5. Use the arrow key to scroll over to “CALC”.
6. Select option 1: “1-Var Stats”
7. Indicate that the data is in L1
8. Scroll down to “Calculate” and hit “Enter”

The summary statistics should now be displayed. You may scroll down with your arrow key to get remaining statistics. Using “1-Var Stats” you can get the sample mean, sample standard deviation, population standard deviation, and 5 number summary.

Chapter 11 – Answers to You Try Problems

11.2A. Adding the prices and dividing by 5 we get the mean price: \$3.682

11.2B. First we put the data in order: \$3.29, \$3.59, \$3.75, \$3.79, \$3.99. Since there are an odd number of data, the median will be the middle value, \$3.75.

11.2C. There are 23 ratings.

a. The mean is $\frac{1 \cdot 4 + 2 \cdot 8 + 3 \cdot 7 + 4 \cdot 3 + 5 \cdot 1}{23} \approx 2.5$

b. There are 23 data values, so the median will be the 12th data value. Ratings of 1 are the first 4 values, while a rating of 2 are the next 8 values, so the 12th value will be a rating of 2. The median is 2.

c. The mode is the most frequent rating. The mode rating is 2.

11.3A. The range of the data is \$0.70.

11.3B. The standard deviation of the data is \$0.26.

11.4A. The data is already in order, so we don't need to sort it first. The minimum value is \$140 and the maximum is \$460.

There are 36 data values so $n = 36$. $n/2 = 18$, which is a whole number, so the median is the mean of the 18th and 19th data values, \$305 and \$310. The median is \$307.50.

To find the first quartile, we calculate the locator, $L = 0.25(36) = 9$. Since this is a whole number, we know Q_1 is the mean of the 9th and 10th data values, \$250 and \$260. $Q_1 = \$255$.

To find the third quartile, we calculate the locator, $L = 0.75(36) = 27$. Since this is a whole number, we know Q_3 is the mean of the 27th and 28th data values, \$345 and \$350. $Q_3 = \$347.50$.

The 5 number summary of this data is: \$140, \$255, \$307.50, \$347.50, \$460

11.4B.

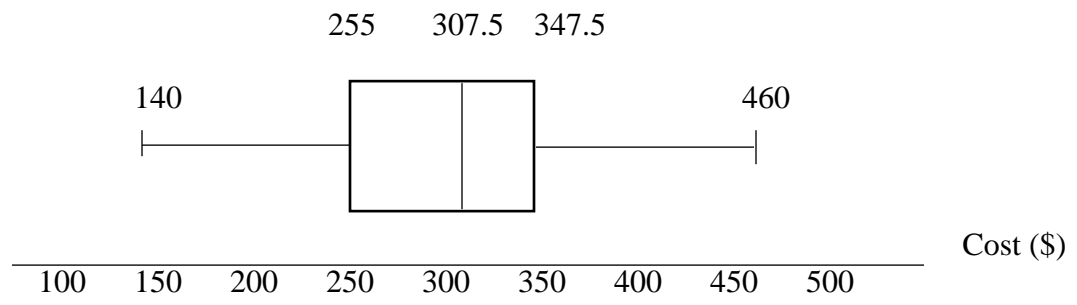

Chapter 11 – Practice Problems

1. The histogram below shows the “Exam Scores” for a sample of 28 students.

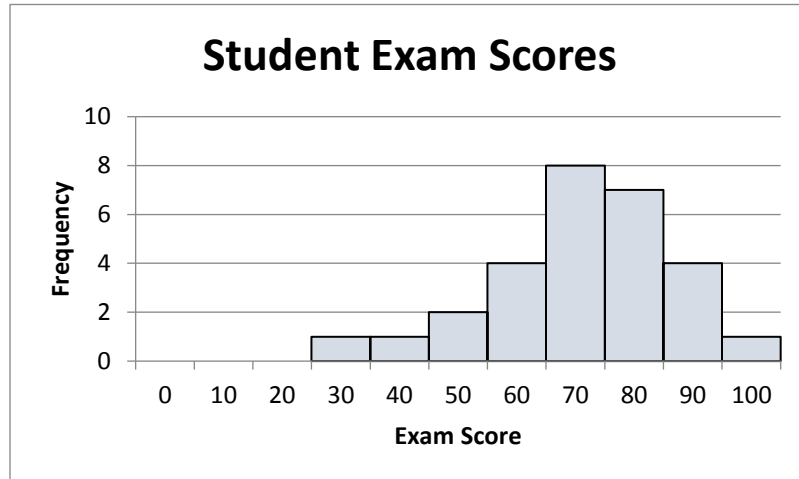

- Is the distribution symmetric or skewed?
 - Classify the shape of the distribution as bell shaped, uniform, right-skewed, or left-skewed.
 - Do there appear to be any outliers in the data set? Why or why not?
2. The histogram below shows the “Exam Scores” for a sample of 28 students.

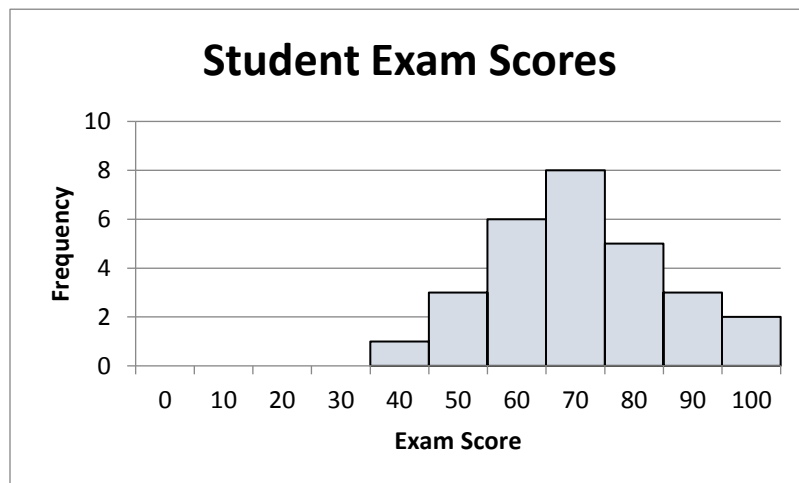

- Is the distribution symmetric or skewed?
- Classify the shape of the distribution as bell shaped, uniform, right-skewed, or left-skewed.
- Do there appear to be any outliers in the data set? Why or why not?

3. The histogram below shows the “Exam Scores” for a sample of 28 students.

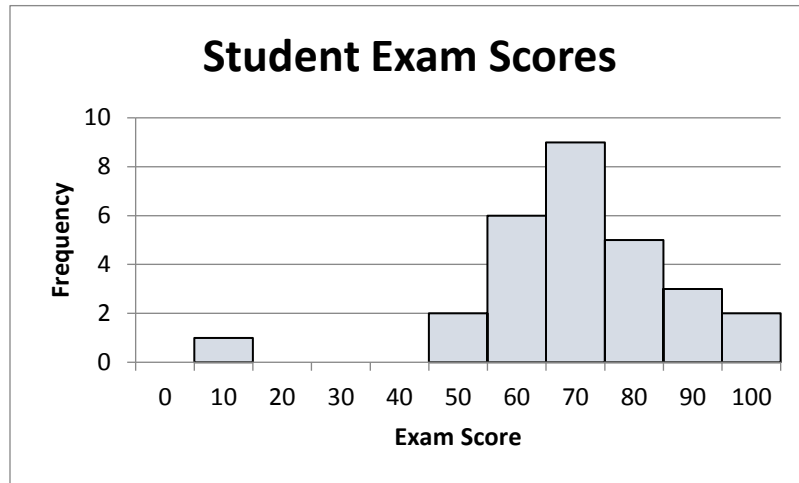

- Is the distribution symmetric or skewed?
 - Classify the shape of the distribution as bell shaped, uniform, right-skewed, or left-skewed.
 - Do there appear to be any outliers in the data set? Why or why not?
4. A student started an online T-shirt business. The histogram below shows the “Number of T-Shirts Sold” over a period of 52 weeks.

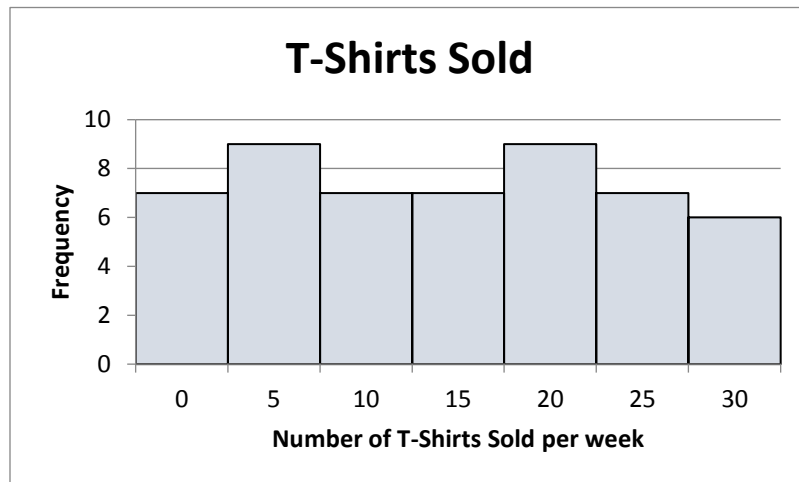

- Is the distribution symmetric or skewed?
- Classify the shape of the distribution as bell shaped, uniform, right-skewed, or left-skewed.
- Do there appear to be any outliers in the data set? Why or why not?

5. A survey was administered at a gym asking people how many hours they spend exercising in one week. The histogram below shows the “Number of Hours Exercising” for a sample of 15 people.

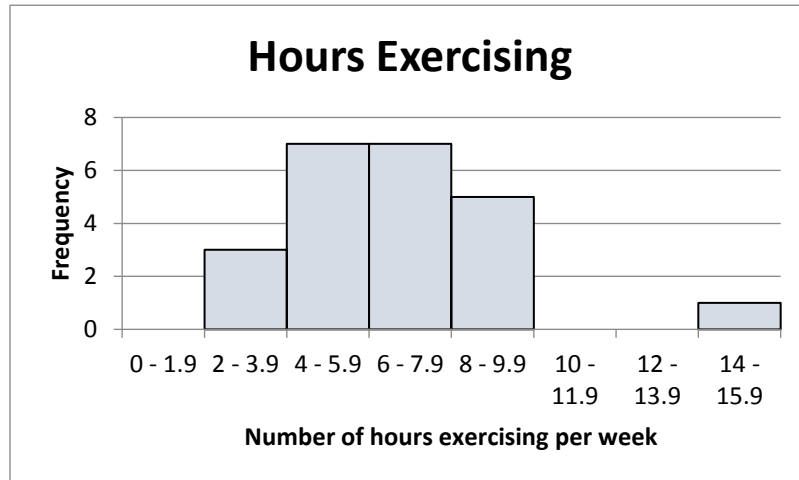

- Is the distribution symmetric or skewed?
 - Classify the shape of the distribution as bell shaped, uniform, right-skewed, or left-skewed.
 - Do there appear to be any outliers in the data set? Why or why not?
6. A group of diners were asked how much they would pay for a meal. Their responses were: \$7.50, \$8.25, \$9.00, \$8.00, \$7.25, \$7.50, \$8.00, \$7.00.
- Find the mean.
 - Find the median.
 - Find the standard deviation.
7. You recorded the time in seconds it took for 8 participants to solve a puzzle. The times were: 15.2, 18.8, 19.3, 19.7, 20.2, 21.8, 22.1, 29.4.
- Find the mean.
 - Find the median.
 - Find the standard deviation.
8. Five real estate exam scores are 430, 430, 480, 480, and 495. Find the mode(s).

9. Refer back to the type of pet(s) owned by a sample of individuals:

Dog Dog Dog Cat Bird Cat Turtle Dog Cat Cat Bird Hamster
 Fish Bird Dog Dog Cat Turtle Hamster Dog Cat Dog Dog
 Bird

- a. What is the mode for type of pet(s) owned?
- b. Why is the mode the best measure of center for this data set?

10. Refer to the histogram:

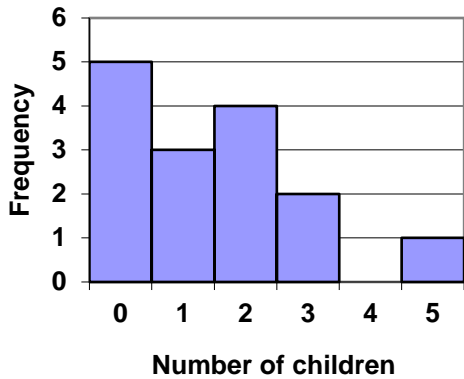

- a. What is the mode of the number of children for the group surveyed?
- b. Compute the mean number of children for the group surveyed.
- c. Compute the median number of children for the group surveyed.

11. Refer to the histogram:

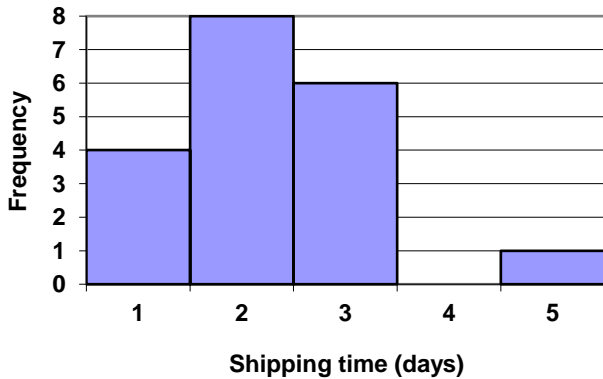

- a. What is the mode of the number of shipping days?
- b. Compute the mean number of shipping days.
- c. Compute the median number of shipping days.

12. Suppose that in a small town of 50 people, one person earns \$5,000,000 per year and the other 49 each earn \$30,000. Calculate both the mean and the median. Which is the better measure of the "center": the mean or the median?

13. The following table provides the tuition rates (in \$ per credit hour) at a sample of 15 colleges and universities.

175	416	87	203	180
257	182	111	315	504
163	218	744	221	1300

- a) Find the mean tuition rate.
b) Find the standard deviation of the tuition rate.
14. A survey of enrollment at 35 community colleges across the United States yielded the following figures:

6414; 1550; 2109; 9350; 21828; 4300; 5944; 5722; 2825; 2044; 5481; 5200;
5853; 2750; 10012; 6357; 27000; 9414; 7681; 3200; 17500; 9200; 7380; 18314;
6557; 13713; 17768; 7493; 2771; 2861; 1263; 7285; 28165; 5080; 11622

- a) Organize the data into a chart with five intervals of equal width. Label the two columns "Enrollment" and "Frequency."
b) Construct a histogram of the data.
c) Calculate the sample mean.
d) Calculate the sample standard deviation.
15. On a baseball team, the ages of each of the players are as follows:
21; 21; 22; 23; 24; 24; 25; 25; 28; 29; 29; 31; 32; 33; 33; 34; 35; 36; 36; 36; 36;
38; 38; 38; 40

- a) Organize the data into a chart with five intervals of equal width. Label the two columns "Age" and "Frequency."
b) Construct a histogram of the data.
c) Calculate the sample mean.
d) Calculate the sample standard deviation.

16. Twenty-five randomly selected students were asked the number of movies they watched the previous week. The results are as follows:

# of movies	Frequency
0	5
1	9
2	6
3	4
4	1

- Find the sample mean.
- Find the standard deviation.
- Find the 5 Number Summary.
- Draw the boxplot.

17. Forty randomly selected students were asked the number of pairs of sneakers they owned. Let X = the number of pairs of sneakers owned. The results are as follows:

# of pairs	Frequency
1	2
2	5
3	8
4	12
5	12
6	0
7	1

- Find the 5 Number Summary for the data set.
- Draw the boxplot for the data set.

18. The following table provides the tuition rates (in \$ per credit hour) at a sample of 15 colleges and universities.

175	416	87	203	180
257	182	111	315	504
163	218	744	221	1300

- Find the 5 Number Summary for the data set.
- Draw the boxplot for the data set.
- Find the 25th percentile for the data set.
- Find the 50th percentile for the data set.

19. Following are the published weights (in pounds) of all of the team members of the San Francisco 49ers from a previous year.

177; 205; 210; 210; 232; 205; 185; 185; 178; 210; 206; 212; 184; 174; 185; 242; 188; 212; 215; 247; 241; 223; 220; 260; 245; 259; 278; 270; 280; 295; 275; 285; 290; 272; 273; 280; 285; 286; 200; 215; 185; 230; 250; 241; 190; 260; 250; 302; 265; 290; 276; 228; 265

- Find the mean of the data.
 - Find the standard deviation of the data.
 - Find the 5 Number Summary
 - Construct a box plot of the data.
20. Sixty-five randomly selected car salespersons were asked the number of cars they generally sell in one week. Fourteen people answered that they generally sell three cars; nineteen generally sell four cars; twelve generally sell five cars; nine generally sell six cars; eleven generally sell seven cars.
- Find the 5 Number Summary for this data set.
 - Construct a box plot for this data set.
 - Find the 50th percentile for the data set.
 - Find the 75th percentile for the data set.

21. The box plot below shows salaries for Actuaries and CPAs.



- What is the 5 Number Summary for CPA's?
 - What is the 5 Number Summary for Actuaries?
 - Kendra makes the median salary for an Actuary. Kelsey makes the first quartile salary for a CPA. Who makes more money? How much more?
22. Referring to the boxplot above, what percentage of actuaries make more than the median salary of a CPA?

23. A survey was conducted of 130 purchasers of new BMW 3 series cars, 130 purchasers of new BMW 5 series cars, and 130 purchasers of new BMW 7 series cars. In it, people were asked the age they were when they purchased their car. The following box plots display the results.

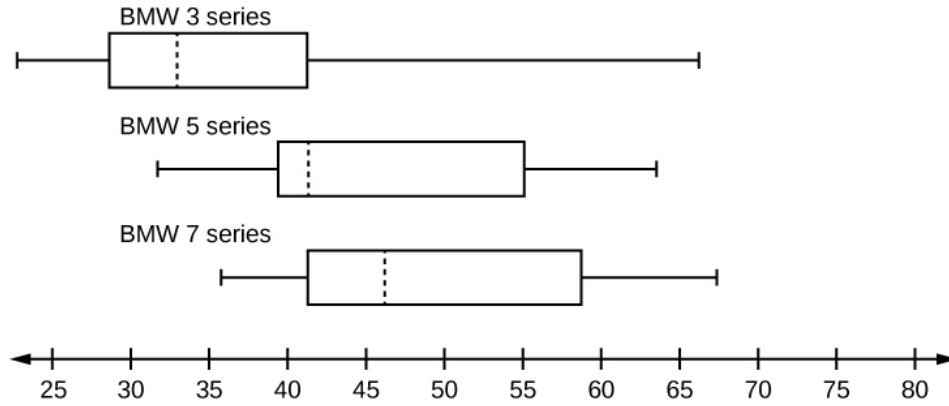

- Which BMW series has the largest median?
 - Which BMW series has the largest standard deviation?
 - As the BMW series increases from 3 to 5 to 7, the price also increases. Does that surprise you, based on the data in the boxplots? Why or why not? Explain your reasoning.
24. Studies are often done by pharmaceutical companies to determine the effectiveness of a treatment program. Suppose that a new AIDS antibody drug is currently under study. It is given to patients once the AIDS symptoms have revealed themselves. Of interest is the average length of time in months patients live once they have started the treatment. Two researchers each follow a different set of 40 AIDS patients from the start of treatment until their deaths. The following data (in months) are collected.

Researcher 1: 3; 4; 11; 15; 16; 17; 22; 44; 37; 16; 14; 24; 25; 15; 26; 27; 33; 29; 35; 44; 13; 21; 22; 10; 12; 8; 40; 32; 26; 27; 31; 34; 29; 17; 8; 24; 18; 47; 33; 34

Researcher 2: 3; 14; 11; 5; 16; 17; 28; 41; 31; 18; 14; 14; 26; 25; 21; 22; 31; 2; 35; 44; 23; 21; 21; 16; 12; 18; 41; 22; 16; 25; 33; 34; 29; 13; 18; 24; 23; 42; 33; 29

- Create comparative histograms of the data.
- Create comparative boxplots of the data.

Chapter 12 – The Normal Distribution

Chapter 12 Learning Objectives:

- Be familiar with properties of the normal distribution
- Be able to apply and interpret the Empirical Rule to a normally distributed variable
- Calculate and interpret the meaning of z-scores
- Find the area under specified regions of the standard normal distribution
- Use z-scores to find the percentage of observations with a specific location for a normally distributed variable

Section 12.1 – The Normal Distribution

Section 12.2 – The Empirical Rule

Section 12.3 - Standard Scores (z – scores)

Section 12.4 – Finding Percentages with Normally Distributed Variables

Section 12.1 – The Normal Distribution

In chapter 10, we learned about sampling, and different ways to collect a random sample that is representative of the desired population. Although the characteristics of the population (population parameters) may be unknown, random sampling can be used to yield reliable estimates of these characteristics. Sample data can be plotted on graphs (like histograms or boxplots) to provide a visual representation of the **distribution** of data values.

Take, for example, the heights of all of the women at SCC. If we were to take a random sample of female SCC students and record their heights, we would most likely find the majority of the heights would be close to a central value, the mean, with larger or smaller values becoming less and less common. The resulting distribution might look something like this:

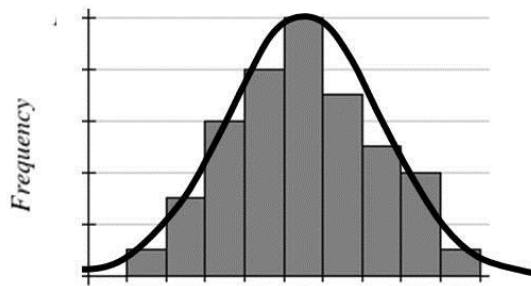

This type of symmetric, bell-shaped distribution is more formally called the **Normal Distribution**. Because actual data are almost never **exactly** normally distributed, we say that the data are **approximately** normal.

The Normal Distribution

Here are a few important characteristics of the Normal Distribution:

- The distribution is symmetric about the mean, with a single peak
- The mean = median = mode of the distribution
- Because the distribution is symmetric, 50% of the data values are below the mean, and 50% of the data values are above the mean (for a total of 100% under the entire distribution curve)
- Data values farther from the mean become increasingly rare.
- The graph of the Normal Distribution is bell-shaped, with tapering tails that approach, but never actually touch the horizontal axis.
- Almost all of the area under a Normal Distribution curve is within 3 standard deviations of the mean.

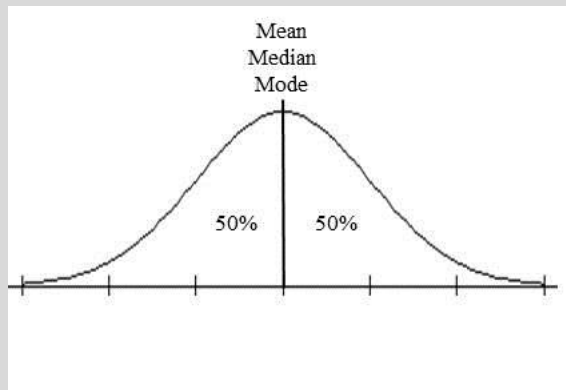

Each tick mark on the horizontal axis is marking off increments of 1 standard deviation above or below the mean.

Example 1

The test scores on a math exam are approximately normally distributed with mean 72 and standard deviation 8. Draw the associated normal distribution curve, and label the axis appropriately.

Since the test scores are approximately normally distributed, we know that the curve is bell-shaped, and centered at its mean of 72. Since the standard deviation is 8, each line on the horizontal axis is 8 units away from the other lines.

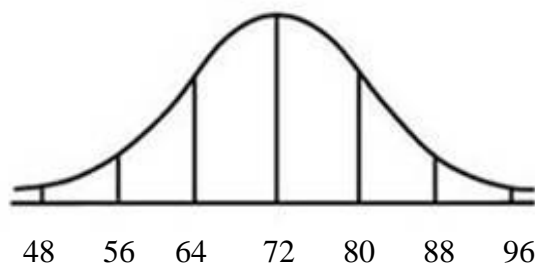

When drawing a normal distribution curve, we usually extend the curve out to three standard deviations below the mean, and three standard deviations above the mean.

You Try 12.1

Draw the normal distribution curve for the variable X that is approximately normally distributed with mean 15 and standard deviation 2.

Section 12.2 – The Empirical Rule

Consider the distributions shown below:

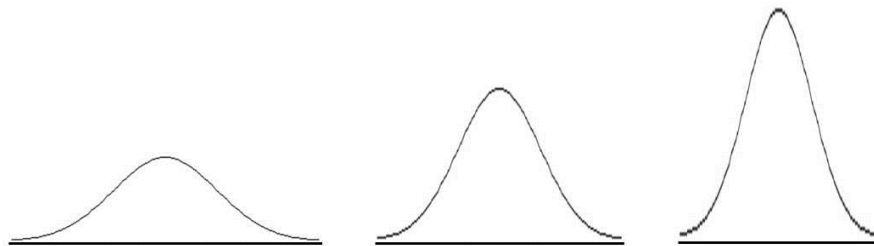

All of them are normally distributed, but each has different variation (spread).

For a Normal Distribution, we use the **standard deviation** to describe the variation, or spread of the data values around the mean. The standard deviation is commonly represented by the lowercase Greek letter sigma, σ .

While each of the above distributions has a different variation, the proportion (or percentage) of the variation is still distributed in the same way for every normal distribution. That may be a bit confusing, but think about the way percentages work. Perhaps you are leaving a tip for a dinner bill, and you always leave a 20% tip. The dollar amount of the tip will be different for a \$100 dinner bill than it would be for a \$50 dinner bill, but in either case you would still leave 20% for the tip.

In the three normal distributions above, the variation is different for each of the 3 curves, but the percentage of the variation that is spread throughout the curve is still organized in the same way. The way the variation is distributed in the curve follows what we call the Empirical Rule (also called the 68-95-99.7 Rule).

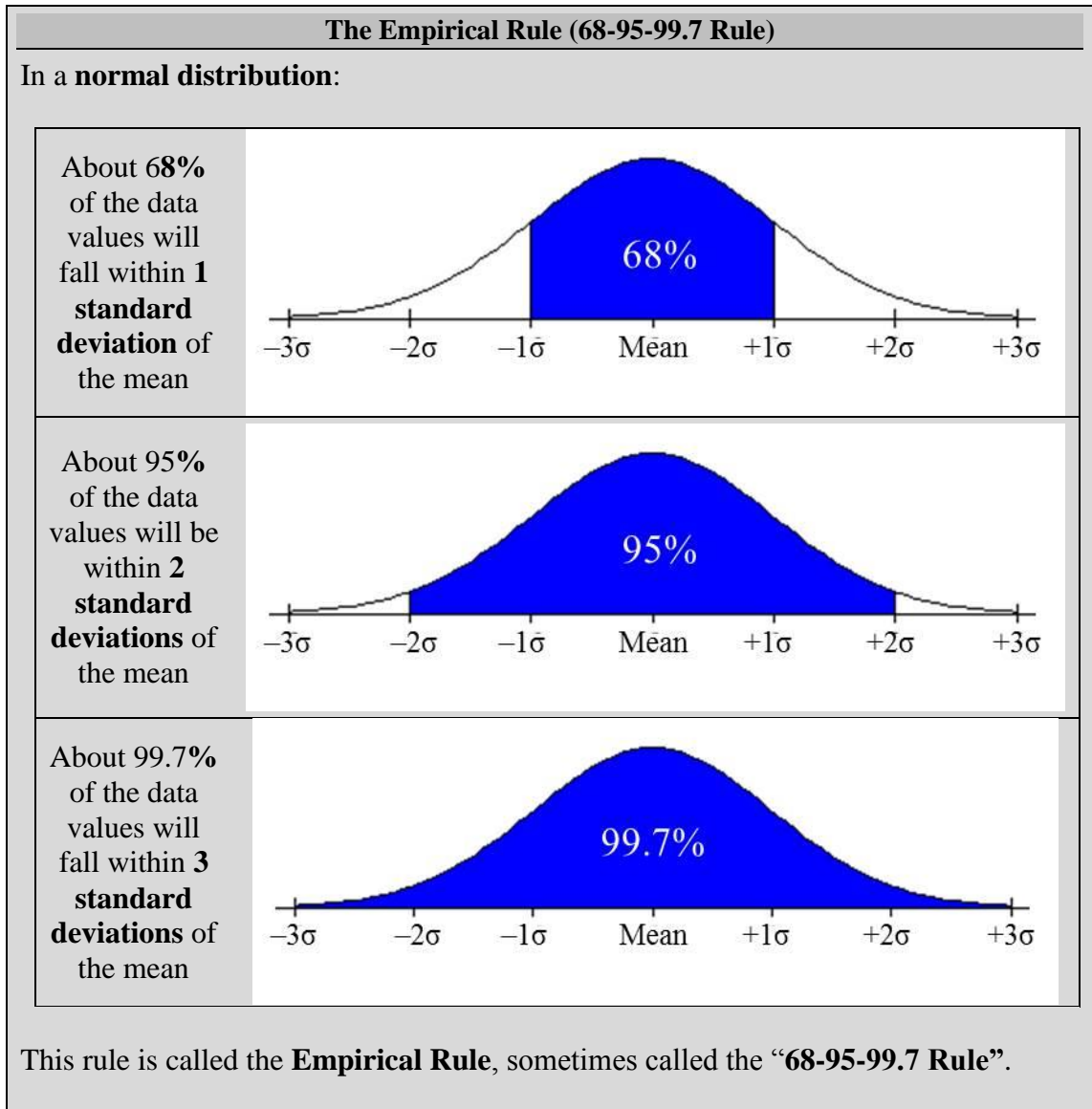

Example 2

Scores on a standardized test were normally distributed with a mean of 510 and a standard deviation of 95. Use the Empirical Rule to complete following statements.

- 68% of the students taking this exam scored between _____ and _____.
- 95% of the students taking this exam scored between _____ and _____.
- 99.7% of the students taking this exam scored between _____ and _____.

You will need to make some calculations. Find the mean: 510.

$$\text{Mean} + 1 \text{ standard deviation} = 510 + 95 = 605$$

$$\text{Mean} + 2 \text{ standard deviation} = 510 + 2(95) = 700$$

$$\text{Mean} + 3 \text{ standard deviation} = 510 + 3(95) = 795$$

$$\text{Mean} - 1 \text{ standard deviation} = 510 - 95 = 415$$

$$\text{Mean} - 2 \text{ standard deviation} = 510 - 2(95) = 320$$

$$\text{Mean} - 3 \text{ standard deviation} = 510 - 3(95) = 225$$

When answering questions like this, it is helpful to draw and label a sketch of the distribution.

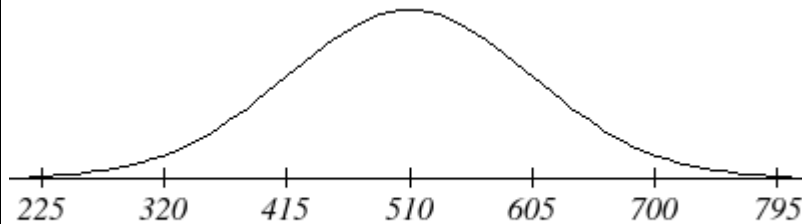

Applying the Empirical Rule, we know that

- 68% of the scores will be within one standard deviation of the mean, so 68% of the students taking this exam scored between 415 and 605.
- 95% of the scores will be within two standard deviations of the mean, so 95% of the students taking this exam scored between 320 and 700.
- 99.7% of the scores will be within three standard deviations of the mean, so 99.7% of the students taking this exam scored between 225 and 795.

You Try 12.2

Gear circumferences for a manufactured bicycle part were normally distributed with a mean of 34 inches and a standard deviation of 0.04 inches.

- Draw and label a sketch of this distribution.
- Use the Empirical Rule to complete following statements.

68% of the students taking this exam scored between _____ and _____.

95% of the students taking this exam scored between _____ and _____.

99.7% of the students taking this exam scored between _____ and _____.

Section 12.3 - Standard Scores (z – scores)

The Empirical Rule only applies when a value is **exactly** 1, 2, or 3 standard deviations away from the mean. This is not usually the case.

A **standard score** (also called “**z-score**”) is the number of standard deviations a data value is from the mean of the distribution. We can plot z-scores on a special normal distribution called the **standard normal distribution**. The standard normal distribution is a normal distribution that always has population mean 0 and population standard deviation of 1.

Standard Scores (z-scores)

A **standard score** (also called “**z-score**”) is the number of standard deviations a specific data value is from the mean of the distribution. Standard scores (often abbreviated by the letter z) have the following characteristics:

- $z = 0$ corresponds to the **mean** of the distribution (because the mean is 0 standard deviations from itself)
- If z is **positive**, then the data value is **above** the mean.
- If z is **negative**, then the data value is **below** the mean.

To calculate the z-score for any data value, x , use the following formula:

$$z = \frac{x - \text{mean}}{\text{standard deviation}}$$

Applying the Empirical Rule to the standard normal distribution, we know that 68% of all z-scores will be between -1 and 1, 95% of all z-scores will be between -2 and 2, and 99.7% of all z-scores will be between -3 and 3. **A z-score below -3 or above 3 is possible, but is very unlikely.**

Example 3

Scores on a standardized test were normally distributed with a mean of 510 and a standard deviation of 95.

- A student scores 365 points on the test. What is his standard score?
- What test score corresponds to a standard score of 2.2?

a. Here, $x = 365$, mean = 510, and standard deviation = 95.

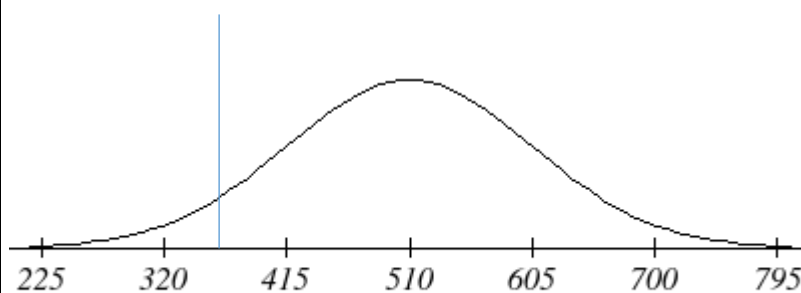

So we have:

$$z = \frac{365 - 510}{95} = \frac{-145}{95} \approx -1.53$$

So this student's score was about 1.53 standard deviations below the mean. You can see visually that the test score of 365 corresponds exactly to the z-score of -1.53 on the standard normal distribution curve below.

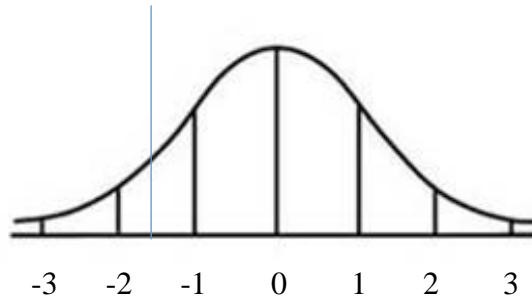

b. Here, $z = 2.2$, mean = 510, and standard deviation = 95.

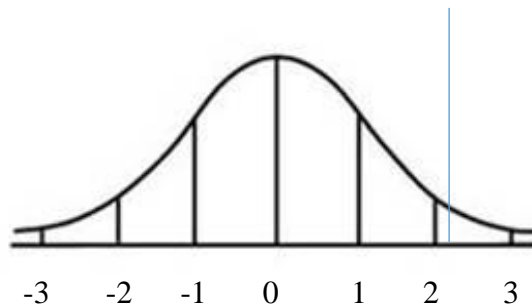

We are solving for x .

$$2.2 = \frac{x - 510}{95} \quad \text{Multiply both sides by 95}$$

$$209 = x - 510 \quad \text{Add 510 to both sides}$$

$$719 = x$$

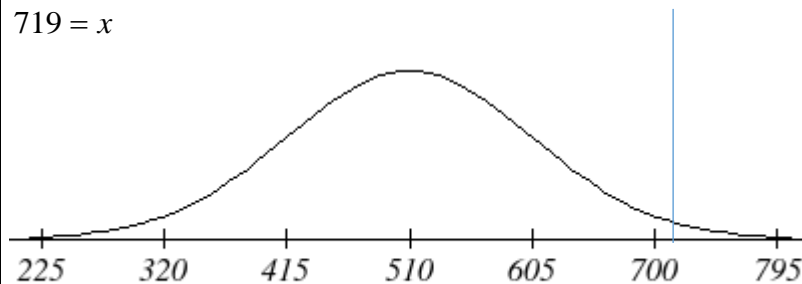

So a test score of 719 corresponds to a standard score of 2.2.

Example 4

The weights of a certain dog breed are approximately normally distributed with a mean of 62 pounds, and a standard deviation of 6 pounds.

- a. A dog of this breed weighs 55 pounds. What is the dog's z-score? Is this dog's weight unusual for this breed?
 b. A dog has a z-score of -3.2. What is the dog's weight?

a. Here, $x = 55$, mean = 62, and standard deviation = 6. So we have:

$$z = \frac{55 - 62}{6} = \frac{-7}{6} \approx -1.17$$

So this dog's weight was about 1.17 standard deviations below the mean. No, the dog's weight is well within 3 standard deviations of the mean, so it is not unusual.

b. Here, $z = -3.2$, mean = 62, and standard deviation = 6. We are solving for x .

$$-3.2 = \frac{x - 62}{6} \quad \text{Multiply both sides by 6}$$

$$-19.2 = x - 62 \quad \text{Add 62 to both sides}$$

$$42.8 = x$$

So a z-score of -3.2 corresponds to a dog that weighs 42.8 pounds. Since this z-score is less than -3, this is an unusually low z-score. This indicates that this dog's weight is unusually low.

You Try 12.3

The lengths of mature trout in a local lake are approximately normally distributed with a mean of 13.2 inches, and a standard deviation of 1.8 inches.

- a. Draw and label the distribution of trout length.
 b. Draw and label the standard normal distribution.
 c. Find the z-score corresponding to a fish that is 19 inches long.
 d. How long is a fish that has a z-score of -0.85?
 e. Draw the z-score from part c on your graph from part b.

Now we know how to convert any value of a variable that is approximately normally distributed into a z-score. This z-score represents a location on the standard normal distribution. You may be thinking, ok, so I can convert an observed value of a variable into a z-score, but why is that useful? In the next section we will begin to answer this question.

Section 12.4 – Finding Percentages with Normally Distributed Variables

We will start out this section with a question:

Why go to the trouble of calculating the z-score that corresponds to an observed value?

We will answer this question through the use of the following examples:

Example 5

Consider the data set consisting of scores on a standardized test. The test scores were normally distributed with a mean of 510 and a standard deviation of 95. What percentage of students scored less than 510 on the test?

We can answer this question using what we already know about normal distributions. Specifically, they are centered about their mean, and symmetric about their mean. If we draw a line to divide the data set at the mean, it is clear that the percentage of observations that are less than the mean should be 50% (with another 50% being greater than the mean).

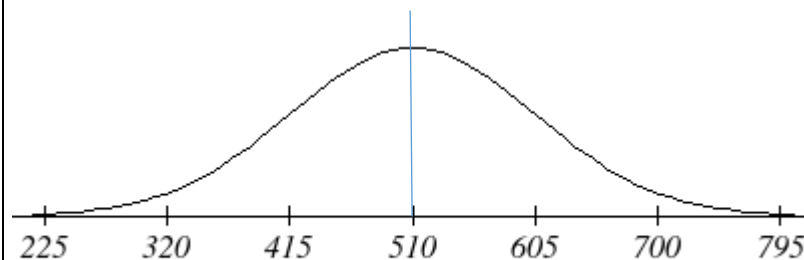

We could answer this question just using properties of normal distributions.

Example 6 (Part I)

Consider again the data set consisting of scores on a standardized test were normally distributed with a mean of 510 and a standard deviation of 95. What percentage of students scored less than 650 on the test?

This is the same question we just answered, but you can see quickly that changing the observed value from 510 to 650 made this question much more difficult to answer. We don't know the exact percentage of scores that are less than 650.

If we had a list of all of the test scores, we could count how many of them were below 650. We could then divide by the total number of scores, and convert to a percentage. That sounds simple enough, but we don't have the list of test scores. So how can we answer this question knowing just the shape of the distribution, the mean, and the standard deviation?

We will come back to this example and answer this question.

At this point, in order to continue solving the problem above, we have to know how to find the percentage of values (areas) under the normal distribution curve with mean 510 and standard deviation 95. That involves complex formulas and calculus. To avoid those requirements, we will use the standard normal distribution curve. Because we learned in the last section how to convert any normally distributed variable into the standard normal, all we need to know are percentages (or areas) under the standard normal distribution curve. These values can be readily looked up using a z-table, or can be found using your graphing calculator.

The following z-table provides areas (percentages of values) under the standard normal curve that lie to the left of specified z-scores.

Abbreviated Table of Areas under the Standard Normal Curve

Note: All values are the area to the LEFT of the specified z-score.
Area to the Right = 1 – Area to the Left

Z-Score	Area	Z-Score	Area	Z-Score	Area	Z-Score	Area
-3.0	0.0013	-1.5	0.0668	0.0	0.5000	1.5	0.9332
-2.9	0.0019	-1.4	0.0808	0.1	0.5398	1.6	0.9452
-2.8	0.0026	-1.3	0.0968	0.2	0.5793	1.7	0.9554
-2.7	0.0035	-1.2	0.1151	0.3	0.6179	1.8	0.9641
-2.6	0.0047	-1.1	0.1357	0.4	0.6554	1.9	0.9713
-2.5	0.0062	-1.0	0.1587	0.5	0.6915	2.0	0.9773
-2.4	0.0082	-0.9	0.1841	0.6	0.7257	2.1	0.9821
-2.3	0.0107	-0.8	0.2119	0.7	0.7580	2.2	0.9861
-2.2	0.0139	-0.7	0.2420	0.8	0.7881	2.3	0.9893
-2.1	0.0179	-0.6	0.2743	0.9	0.8159	2.4	0.9918
-2.0	0.0228	-0.5	0.3085	1.0	0.8413	2.5	0.9938
-1.9	0.0287	-0.4	0.3446	1.1	0.8643	2.6	0.9953
-1.8	0.0359	-0.3	0.3821	1.2	0.8849	2.7	0.9965
-1.7	0.0446	-0.2	0.4207	1.3	0.9032	2.8	0.9974
-1.6	0.0548	-0.1	0.4602	1.4	0.9192	2.9	0.9981

Finding Areas to the Left of Z-Scores

Example 6 (Part II)

Let's go back to the previous example, using what we now know about finding percentages under the standard normal distribution curve. Our data consisted of scores on a standardized test that were normally distributed with a mean of 510 and a standard deviation of 95. We wanted to know what percentage of students scored less than 650 on the test.

As starting point, we will calculate the z-score that corresponds to a test score of 650.

$$z = \frac{650 - 510}{95} = \frac{140}{95} = 1.47$$

This tells us that the percentage of students who score less than 650 on the test will be equal to the percentage of observations that are less than 1.47 under the standard normal curve.

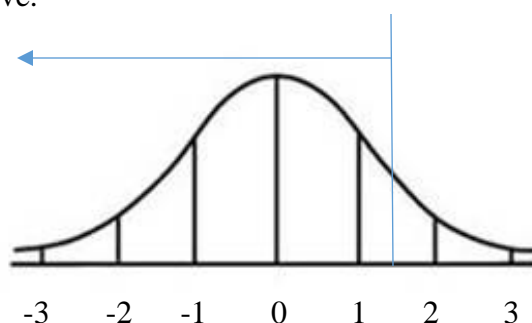

Using the z-table: Look in the z-score columns to find the integer and first decimal in your z-score. For this example, we will round 1.47 to 1.5. The area from the table is .9332. We can say that approximately 93.32% of all test scores were less than 650.

Using your graphing calculator: Press the “2nd” key, followed by the “Distr” key (below and to the left of the arrows). Choose option “2:normalcdf(“ and press “Enter”. The calculator will ask you for the lower bound. This should be the z-score that is the leftmost boundary of the area you are trying to find. Since in this case we want all the area to the left of 1.47, there is no lower bound. Type -1,000,000 as your lower value. The calculator will ask you for the upper bound. In this example, the upper bound is 1.47 since we want the percentage of all values less than 1.47. You should enter 0 for the mean, and 1 for the standard deviation since this is a standard normal distribution. Press “Enter”, when you see a blinking cursor press “Enter” again. Your calculator should output 0.9292190874. We would round this to 0.9292, or 92.92%. The table on the next page will walk you through this process, in general.

NOTE: The table will give slightly different answers than the calculator. The table is an approximation (with rounding error) to the actual percentages, while the calculator gives you a much more accurate answer.

Finding Areas Under the Normal Curve on Your Graphing Calculator

Press the “2nd” key, followed by the “Distr” key (below and to the left of the arrows). Choose option “2:normalcdf(“ and press “Enter”. The calculator will ask you for the lower bound, the upper bound, the mean, and the standard deviation.

normalcdf(lower bound, upper bound, mean, standard deviation)

Since we are working with the *Standard Normal Distribution*, the mean = 0 and the standard deviation = 1.

Find the shaded areas below.

1. Find the area between two z-scores, z_1 and z_2 .

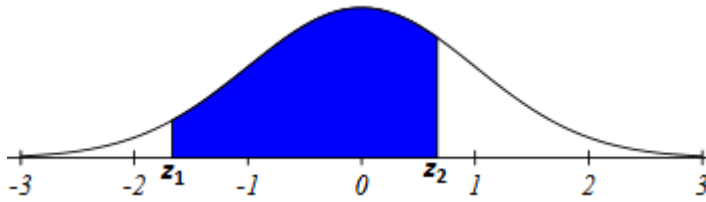

Lower bound = z_1
 Upper bound = z_2
 Mean = 0
 Standard Deviation = 1

normalcdf($z_1, z_2, 0, 1$)

2. Find the area below z .

NOTE: Since there is no lower bound, we choose -1,000,000 for the lower bound.

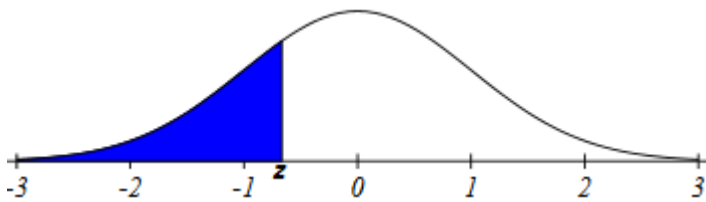

Lower bound = -1,000,000
 Upper bound = z
 Mean = 0
 Standard Deviation = 1

normalcdf(-1000000, $z, 0, 1$)

3. Find the area above z .

NOTE: Since there is no upper bound, we choose 1,000,000 for the upper bound.

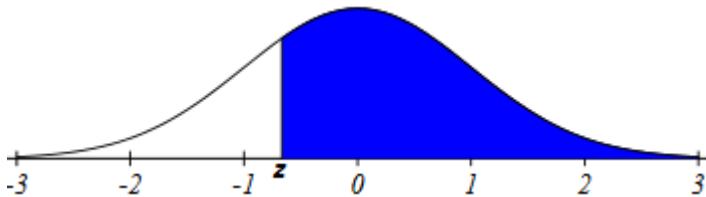

Lower bound = z
 Upper bound = 1,000,000
 Mean = 0
 Standard Deviation = 1

normalcdf($z, 1000000, 0, 1$)

Example 7

The weights of a certain dog breed are approximately normally distributed with a mean of 62 pounds, and a standard deviation of 6 pounds. Find the percentage of dogs of this breed that weigh less than 55 pounds.

We need to start out by finding the z-score that corresponds to a dog weighing 55 pounds.

$$z = \frac{55-62}{6} = \frac{-7}{6} = -1.17$$

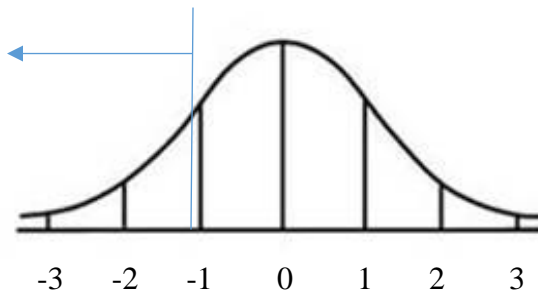

In the abridged z-table, we don't have -1.17. The closest value to -1.17 is -1.2. Our answer will be an approximation. The corresponding area to the left is 0.1151. The percentage of dogs of this breed that weigh less than 55 pounds is approximately 11.51%.

In the graphing calculator, under 2nd Distr we need to enter -1,000,000 again for the lower bound. For the upper bound we will enter -1.17. The resulting output is 0.1210. The percentage of dogs of this breed that weigh less than 55 pounds is about 12.10%.

Finding Areas to the Right of Z-Scores

Example 8

The weights of a certain dog breed are approximately normally distributed with a mean of 62 pounds, and a standard deviation of 6 pounds. Find the percentage of dogs of this breed that weigh MORE than 55 pounds.

We need to start out by finding the z-score that corresponds to a dog weighing 55 pounds.

$$z = \frac{55 - 62}{6} = \frac{-7}{6} = -1.17$$

This time we need to find the percentage of z-scores that are greater than -1.17 (or to the right of -1.17).

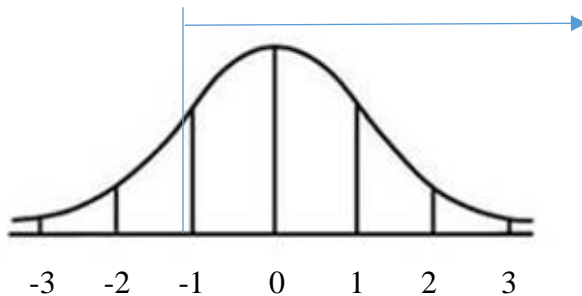

In the graphing calculator, under 2nd Distr we need to enter -1.17 for the lower bound. For the upper bound we will enter 1,000,000. The resulting output is 0.8790. The percentage of dogs of this breed that weigh MORE than 55 pounds is 87.90%.

Recall, the total area under a distribution curve is 1 (or 100%). In Example 7 we found the area to the LEFT of $z = -1.17$ and in Example 8 we found the area to the RIGHT of $z = 1.17$. Notice that the area to the left (0.1210) plus the area to the right (0.8790) of the same z-score will always sum to 1.

The previous example illustrates an important property about areas under the standard normal distribution. Since the total percentage of values under the distribution curve is always equal to 100% (or 1) the area to the left of a z-score plus the area to the right of that same z-score will always equal 1 (or 100% of the observations).

You Try 12.4A

The annual rainfall in a certain region is approximately normally distributed with mean 33.5 inches and standard deviation 5.6 inches.

- What percentage of years will have an annual rainfall of less than 30 inches?
- What percentage of years will have an annual rainfall of more than 40 inches?

Finding the Area Between Two Z-Scores

Recall that in Section 12.2 we learned the Empirical Rule (or 68-95-99.7 Rule). This rule allowed us to find the percentage of observations that lied between specific values of our variable. While this is useful, there are many occasions where the data values we are interested in do not happen to fall right at 1, 2, or 3 standard deviations away from the mean.

We know from the Empirical Rule that about 68% of all observations will fall between -1σ and 1σ (between -1 and 1 in the standard normal distribution)

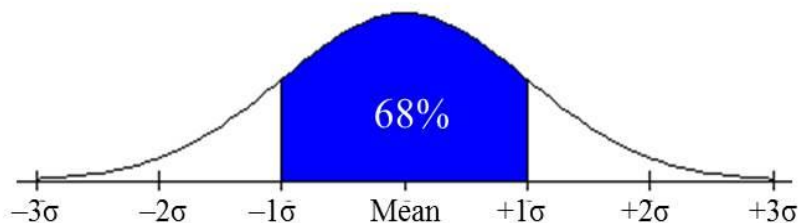

What if we wanted to find the percentage of all observations that will have z-scores between -2 and 2 ? Again, using the Empirical Rule, we know the answer is approximately 95%.

What if we wanted to find the percentage of all observations that will have z-scores between -1.5 and 1.5 ? This becomes much more challenging. We would expect the answer to be between 68% and 95%, but we can now get much more precise.

Example 9

A scientist finds that the heights of a certain tree are approximately normally distributed with mean 20 feet and standard deviation 4 feet.

The associated normal distribution curve is as follows:

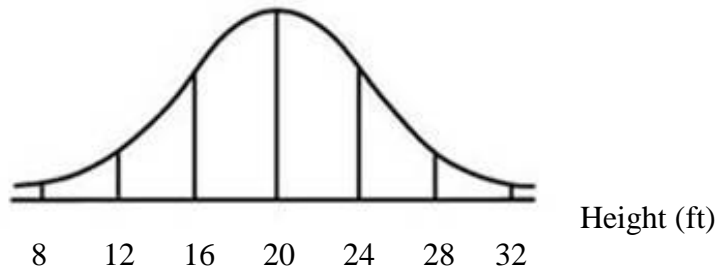

Suppose we are asked to find the percentage of all such trees that are between 14 and 26 feet tall.

The percentage of trees that are between 14 and 26 feet tall corresponds to the percentage of values that are between the two lines drawn on the curve below:

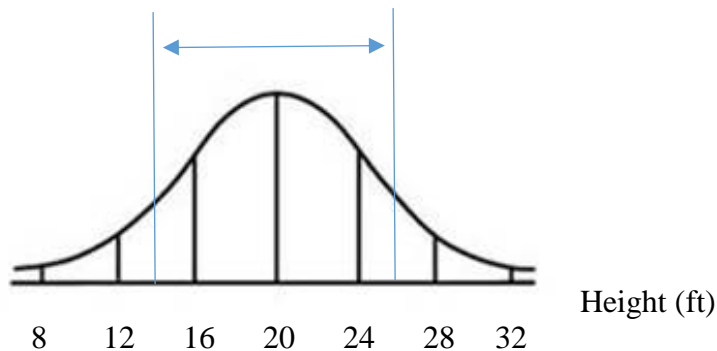

We can find the associated z-scores that correspond to tree heights of 14 ft. and 26 ft. using the z-score formula from the previous section:

$$z = \frac{14 - 20}{4} = \frac{-6}{4} = -1.5 \quad \text{and} \quad z = \frac{26 - 20}{4} = \frac{6}{4} = 1.5$$

We now know that the percentage of trees between 14 and 26 feet tall is the same as the percentage of observations between -1.5 and 1.5 under the standard normal distribution.

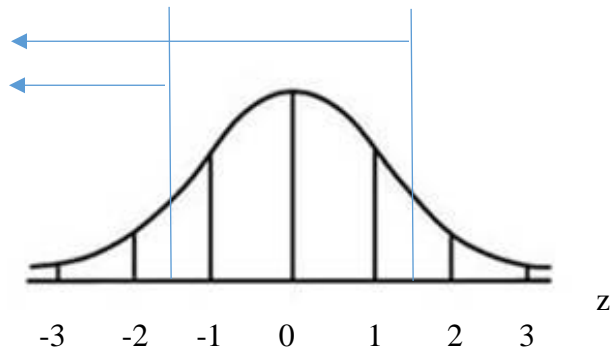

Using the table, the area that we are looking for is the area BETWEEN -1.5 and 1.5. If we subtract the area to the left of -1.5 from the area to the left of 1.5, our answer will be just the remaining area between the two z-scores.

$$\text{Area to the left of } -1.5 = 0.0668$$

$$\text{Area to the left of } 1.5 = 0.9332$$

Area in between -1.5 and 1.5 = $0.9332 - 0.0668 = 0.8664$. Therefore, 86.64% of trees are between 14 and 26 feet tall.

Using the calculator, our lower bound would be -1.5 and our upper bound would be 1.5. The resulting percentage of trees that are between 14 and 26 feet tall is 86.64%.

You Try 12.4B

The annual rainfall in a certain region is approximately normally distributed with mean 33.5 inches and standard deviation 5.6 inches. What percentage of years will have an annual rainfall of between 30 and 40 inches?

Chapter 12 – Answers to You Try Problems

12.1.

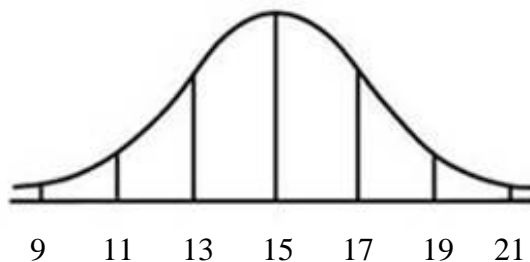

12.2. a.

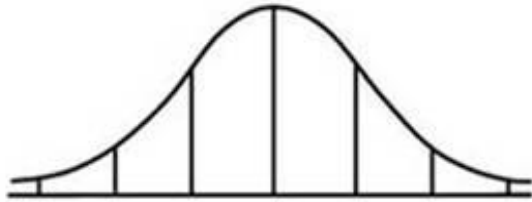

33.88 33.92 33.96 34 34.04 34.08 34.12

b.

68% of the gears have circumferences between 33.96 and 34.04 inches
 95% of the gears have circumferences between 33.92 and 34.08 inches
 99.7% of the gears have circumferences between 33.88 and 34.12 inches

12.3. a.

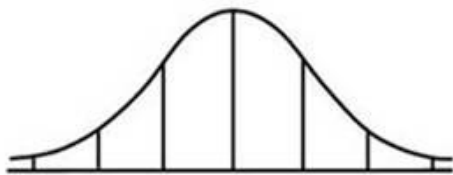

7.8 9.6 11.4 13.2 15 16.8 18.6

b.

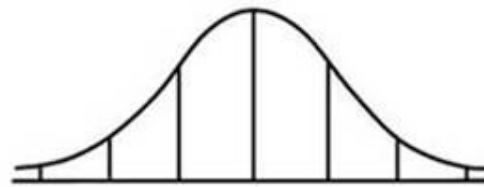

-3 -2 -1 0 1 2 3

c. $z = 3.22$ d. 11.67 inches

e.

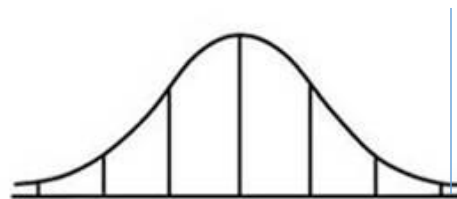

-3 -2 -1 0 1 2 3

12.4A. a. $z = -0.63$. Area to the left of -0.63 is 0.2643, or 26.43%

b. $z = 1.16$. Area to the right of 1.16 is 0.1230, or 12.30%

12.4B. $0.8770 - 0.2643 = .6127$. In this region, 61.27% of all years will have annual rainfall between 30 and 40 inches.

Chapter 12 – Practice Problems

1. A normal distribution has a mean of 61 and a standard deviation of 15. What is the median?
2. In a normal distribution, what percentage of observations will lie to the left of the mean?
3. Suppose a normal distribution has a mean of six and a standard deviation of 1.5. Draw the associated normal distribution curve, labeling the axis appropriately.
4. Suppose a normal distribution has a mean of 45 and a standard deviation of 10. Draw the associated normal distribution curve, labeling the axis appropriately.
5. Suppose a normal distribution has a mean of -5 and a standard deviation of 2. Draw the associated normal distribution curve, labeling the axis appropriately.
6. Two normal distributions have the same means, but different standard deviations. Distribution A has a standard deviation of 10, and Distribution B has a standard deviation of 15. Which curve has wider spread along the horizontal axis? Why?
7. About what percent of x values from a normal distribution lie within one standard deviation (left and right) of the mean of that distribution?
8. About what percent of the x values from a normal distribution lie within two standard deviations (left and right) of the mean of that distribution?
9. About what percent of x values lie between the second and third standard deviations (both sides)?
10. Suppose the variable X is normally distributed with mean 15 and standard deviation 3. Between what x values does 68% of the data lie? Note: The range of x values is centered at the mean of the distribution.
11. Suppose X is normally distributed with mean -3 and standard deviation 1. Between what x values does 95% of the data lie? Note: The range of x values is centered at the mean of the distribution.
12. About what percent of x values lie between the mean and three standard deviations?
13. About what percent of x values lie between the mean and one standard deviation?

14. About what percent of x values lie between the first and second standard deviations from the mean (both sides)?
15. About what percent of x values lie between the first and third standard deviations (both sides)?
16. What does a z -score measure?
17. Consider the standard normal distribution. The mean is always _____ and the standard deviation is always _____.
18. What is the z -score of $x = 12$, if it is two standard deviations to the right of the mean?
19. What is the z -score of $x = 9$, if it is 1.5 standard deviations to the left of the mean?
20. What is the z -score of $x = -2$, if it is 2.78 standard deviations to the right of the mean?
21. What is the z -score of $x = 7$, if it is 0.133 standard deviations to the left of the mean?
22. Suppose X is normally distributed with mean -1 and standard deviation 2 . What is the z -score of $x = 2$?
23. Suppose a variable is approximately normally distributed with mean 12 and standard deviation 6 . What is the z -score of $x = 2$?
24. Suppose a variable is normally distributed with mean 9 and standard deviation 3 . What is the z -score of $x = 9$?
25. Suppose a normal distribution has a mean of six and a standard deviation of 1.5 . What is the z -score of $x = 5.5$?
26. In a normal distribution, $x = 5$ and $z = -1.25$. This tells you that $x = 5$ is _____ standard deviations to the _____ (right or left) of the mean.
27. In a normal distribution, $x = 3$ and $z = 0.67$. This tells you that $x = 3$ is _____ standard deviations to the _____ (right or left) of the mean.
28. In a normal distribution, $x = -2$ and $z = 6$. This tells you that $x = -2$ is _____ standard deviations to the _____ (right or left) of the mean.

29. In a normal distribution, $x = -5$ and $z = -3.14$. This tells you that $x = -5$ is ____ standard deviations to the ____ (right or left) of the mean.
30. In a normal distribution, $x = 6$ and $z = -1.7$. This tells you that $x = 6$ is ____ standard deviations to the ____ (right or left) of the mean.
31. The life of Sunshine DVD players is normally distributed with mean of 4.1 years and a standard deviation of 1.3 years. A DVD player is guaranteed for three years. We are interested in the length of time a DVD player lasts. Find the z-score corresponding to the guaranteed life of 3 years.
32. The heights of the 430 National Basketball Association players were listed on team rosters at the start of the 2005-2006 season. The heights of basketball players have an approximately normal distribution with mean 79 inches and a standard deviation 3.89 inches. For each of the following heights, calculate the z-score and interpret it using complete sentences.
- a) 77 inches
 - b) 85 inches
33. The systolic blood pressure (given in millimeters) of males has an approximately normal distribution with mean 125 and standard deviation 14. Systolic blood pressure for males follows a normal distribution.
- a) Calculate the z-scores for the male systolic blood pressures 100 and 150 millimeters.
 - b) If a male friend of yours said he thought his systolic blood pressure was 2.5 standard deviations below the mean, but that he believed his blood pressure was between 100 and 150 millimeters, what would you say to him?
34. A variable is normally distributed with mean 2 and standard deviation 6. What value of x has a z-score of three?
35. Suppose a variable has mean 8, standard deviation 1, and is normally distributed. What value of x has a z-score of -2.25?
36. Suppose a normally distributed variable has mean 4 and standard deviation 2. What value of x is 1.5 standard deviations to the left of the mean?
37. A variable is normally distributed with mean 4 and standard deviation 2. What value of x is two standard deviations to the right of the mean?

38. The life of Sunshine DVD players is normally distributed with mean of 4.1 years and a standard deviation of 1.3 years. How long does a DVD player last if its z-score is -2.0?
39. The heights of the 430 National Basketball Association players were listed on team rosters at the start of the 2005-2006 season. The heights of basketball players have an approximately normal distribution with mean 79 inches and a standard deviation 3.89 inches.
- If an NBA player reported his height had a z-score of 3.5, would you believe him? Explain your answer.
 - If an NBA player reported his height had a z-score of -3.5, would you believe him? Explain your answer.
40. The systolic blood pressure (given in millimeters) of males has an approximately normal distribution with mean 125 and standard deviation 14.
- Find the systolic blood pressure of a man with a z-score of 0.75. Is this an unusual systolic blood pressure? Why or why not?
 - Find the systolic blood pressure of a man with a z-score of 3.2. Is this an unusual systolic blood pressure? Why or why not?
41. If the area to the left of X in a normal distribution is 0.123, what is the area to the right of x ?
42. If the area to the right of x in a normal distribution is 0.543, what is the area to the left of x ?
43. A variable is normally distributed with mean 16 and standard deviation 3. Find each of the following. Draw the associated normal curve, shading the solution region.
- Find the area to the left of 12.
 - Find the area to the left of 20.
 - Find the area to the right of 15.
 - Find the area to the right of 24.
 - Find the area between 12 and 20.

44. A variable is normally distributed with mean 84.6 and standard deviation 19.1. Find each of the following. Draw the associated normal curve, shading the solution region.
- Find the area to the left of 60.5.
 - Find the area to the right of 60.5.
 - Find the area to the left of 128.0.
 - Find the area to the right of 119.3.
 - Find the area between 80 and 90.
45. A variable is normally distributed with mean 45 and standard deviation 4.6. Find each of the following. Draw the associated normal curve, shading the solution region.
- Find the area to the left of 27.
 - Find the area to the left of 45.
 - Find the area to the right of 52.
 - Find the area to the right of 38.
 - Find the area between 33 and 48.
46. The patient recovery time from a particular surgical procedure is normally distributed with a mean of 5.3 days and a standard deviation of 2.1 days.
- What is the probability of spending less than two days in recovery?
 - What is the probability of spending more than two days in recovery?
 - What is the probability of spending more than 10 days in recovery?
47. According to a study done by De Anza students, the height for Asian adult males is normally distributed with an average of 66 inches and a standard deviation of 2.5 inches. Suppose one Asian adult male is randomly chosen. Let X = height of the individual.
- Find the probability that the person is between 65 and 69 inches. Include a sketch of the graph.
 - Would you expect to meet many Asian adult males over 72 inches? Explain why or why not, and justify your answer numerically.

48. IQ is normally distributed with a mean of 100 and a standard deviation of 15. Suppose one individual is randomly chosen. Let $X = \text{IQ of an individual}$.
- Find the probability that the person has an IQ greater than 120. Include a sketch of the graph.
 - Find the probability that the person has an IQ less than 60. Include a sketch of the graph.
49. The percent of fat calories that a person in America consumes each day is normally distributed with a mean of about 36 and a standard deviation of 10. Suppose that one individual is randomly chosen. Let $X = \text{percent of fat calories}$.
- Find the probability that the percent of fat calories a person consumes is more than 40. Graph the situation. Shade in the area to be determined.
 - Find the probability that the percent of fat calories a person consumes is between 10 and 20. Graph the situation. Shade in the area to be determined.
50. Suppose that the distance of fly balls hit to the outfield (in baseball) is normally distributed with a mean of 250 feet and a standard deviation of 50 feet.
- If one fly ball is randomly chosen from this distribution, what is the probability that this ball traveled fewer than 220 feet? Sketch the graph. Shade the area to be determined.
 - If one fly ball is randomly chosen from this distribution, what is the probability that this ball traveled more than 350 feet? Sketch the graph, and shade the area to be determined.

Appendix A - Answers to Practice Problems (Chapters 1-12)

Chapter 1

- 30 cm
- 23cm
- 198 units
- 96.7 units
- 25 units
- 24 m^2
- 63 in^2
- Area: 80 cm^2
Perimeter: 44 cm
- Area: $2,600 \text{ units}^2$
Perimeter: 212 units
- Exact: $\sqrt{128}$ in
Approximate: 11.31 in
- Exact: $\sqrt{261}$ cm
Approximate: 16.16 cm
- Exact: $\sqrt{48}$ in
Approximate: 6.93 in
- Exact: $\sqrt{119}$ cm
Approximate: 10.91 cm
- a) 15.59 inches
b) 140.31 square inches
- a) \$2,520,000
b) \$1,942,017
c) \$577,983
- 192.1 miles
- 4 m
- 10.5 in
- Circumference: 50.27 cm
Area: 201.06 cm^2
- Circumference: 25.13 in
Area: 50.27 in^2
- Exact: $625\pi \text{ in}^2$
Approximate: $1,963.5 \text{ in}^2$
- Circumference
Exact: $26\pi \text{ ft}$
Approximate: 81.7 ft
Area
Exact: $169\pi \text{ ft}^2$
Approximate: 530.9 ft^2
- Perimeter: 22 ft
Area: 36 ft^2
- Perimeter: 141.42 ft
Area: 937.08 ft^2
- Perimeter: 98 m
Area: 544 m^2
- Perimeter: 107.98 cm
Area: 601.94 cm^2
- 234 in^3
- $1,256.6 \text{ ft}^2$

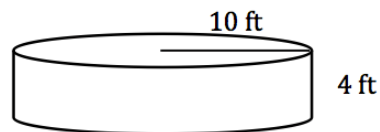

29. 410.5 ft^2

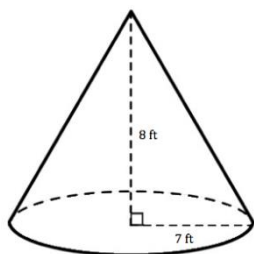

30. 120 ft

31. 10.6 ft

32. 252 ft^2

33. Width: 156 ft

Area: $10,608 \text{ ft}^2$

34. 87.96 ft^2

35. a) Studio A: $1,800 \text{ ft}^2$

Studio B: $2,200 \text{ ft}^2$

b) Studio A: \$0.75 per sq ft

Studio B: \$0.68 per sq ft

36. a) 1940.26 feet

b) 330,814.33 square feet

c) 7.59 acres

37. $1,560 \text{ ft}^3$

38. $14,137.17 \text{ cm}^3$

39. a) $10,648 \text{ cm}^3$

b) $5,575.28 \text{ cm}^3$

c) $5,072.72 \text{ cm}^3$

Chapter 2

1. 96 in

2. 15 ft

3. 216 in

4. 3 yd

5. 357,456 yd

6. 17,436,672 in

7. 110 in

8. 10.08 ft

9. 64 oz

10. 2.38 lb

11. 0.013 tons

12. 9 lbs 4 oz

13. 12 lbs 2 oz

14. 3.04 gal

15. 149.84 gal

16. 288 oz

17. 27.6 cups

18. 3-quart saucepan (2.25 qts of soup)

19. 700 cm

20. 3.52 L

21. 4,830 mL

22. 0.004 m

23. 4.15 m

24. 1.84 kg

25. 6,000 g

26. 3.64 cm

27. 35,200 mg

28. 22 L

29. 9.5 km

30. 2.96 kg

31. 2.36 inches

32. 11.43 centimeters

33. 382.76 yards

34. 11.59 kilometers

35. 74.84 kilograms

36. 1.76 pounds

37. 60.56 liters
38. 437.45 feet
39. 12.22°C
40. 23.89°C
41. 10.4°F
42. 98.6°F
43. 722.64 euros
44. Rate: $\frac{540 \text{ ft}}{30 \text{ sec}}$
Unit rate: $\frac{18 \text{ ft}}{1 \text{ sec}}$ or 18 ft per second
45. a) 863.64 mi
b) 37.63 gal
46. 938.7 ft
47. 290.4 ft
48. 66.7 m
49. 55.6 m
50. 53.33 oz.
51. One quart
52. \$70
53. \$6,000
54. 972 calories
55. 73.3 turbines
56. 2,666.67 dump trucks
57. \$3,003
58. 4 lemons
59. 64 mg
60. 132 ft
61. 3,300 ft
62. 34 min
63. 3.7 yd³
64. 5.53 dollars per gallon

65. 3.62 dollars per ounce

Chapter 3

1. After 124 packages of cookies have been sold, the wholesale price of one package is \$0.80.
2. It costs \$160 dollars to produce 751 gallons of chocolate chunk ice cream.
3. In 2024 the total average credit card debt in a U.S. household will be approximately \$21,500.
4. a) 4 hours after leaving his house, Billy has driven 160 miles.
b) 0.1 hours after leaving his house, Billy has driven 2 miles.
5. a) 24
b) 3
c) 3
6. a) 4
b) -4
c) 1
d) -2
7. a) -2
b) 2
c) -1
d) 3
8. a) -3
b) 2
c) -4

9. a) -15
b) 9
c) 6
10. Rate of change = 3
Initial value = 7
11. Rate of change = -10
Initial value = -9
12. Rate of change = -5
Initial value = 0
13. Rate of change = 0
Initial value = 1
14. 3
15. -2
16. 0
17. Rate of change = 21
Initial value = 14
18. Rate of change = -39
Initial value = -6
19. Rate of change = 38
Initial value = 62
20. The value of the investment decreases by \$5,400 every year.
21. The value of the investment increases by \$2,500 every year.
22. Paul's profit will increase by \$1.4 for each additional bottle of water sold.
23. a) $N(t) = 44t + 440$
b) $N(t) = -32t + 440$
c) $N(t) = 440$
24. a) $P(x) = 1,700x + 59,000$
b) 65,800 people
c) 2014
25. a) $T(n) = 30n + 1,300$
b) \$133,300
c) 4,100 toys
26. -77.6 feet per year
27. a) \$1,400 per year
b) Increasing
28. a) \$1,600 per year
b) Increasing
29. a) \$13 per credit hour per year
b) $C(n) = 13n + 105$
c) \$326
d) 2014
30. 28 lunches; \$2
31. a) Slim Gym (Phoenix Fitness = \$519; Slim Gym = \$490)
b) Phoenix Fitness (Phoenix Fitness = \$939; Slim Gym = \$970)
32. a)

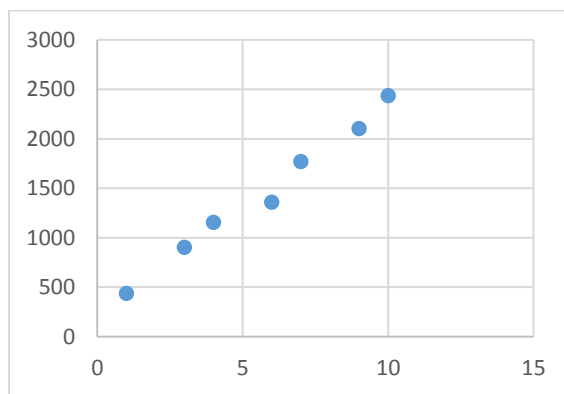

b) Increasing

c) Yes

33. a)

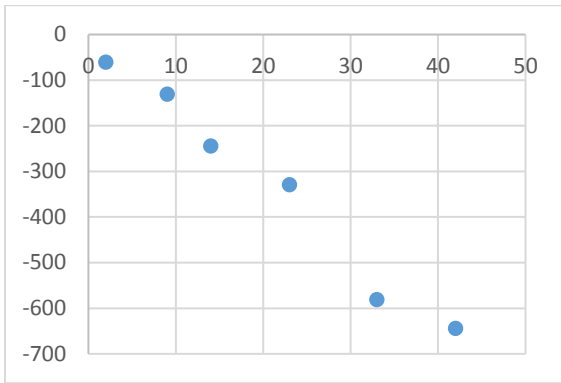

b) Decreasing c) Yes

34. a)

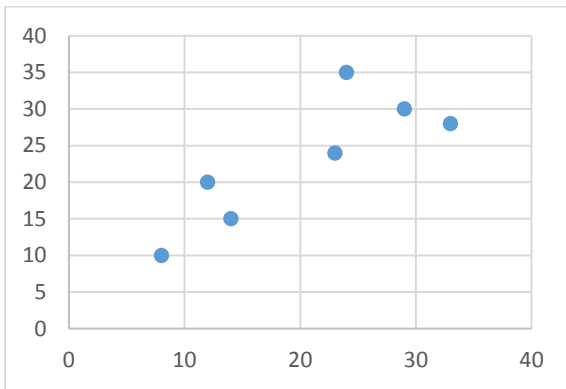

b) Increasing c) Roughly linear

35. a)

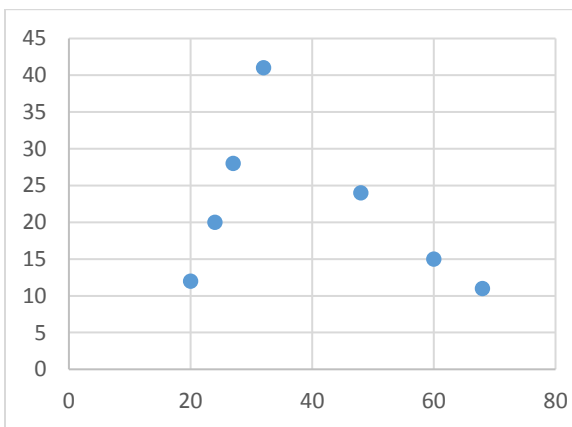

b) Both, neither one consistently
c) No

36. $y = 213.3x + 232.4$

37. $y = -15.5x - 12.9$

38. $y = 0.79x + 7.10$

39. a. $r = 0.38$ b. $r = -0.85$
c. $r = -0.15$ d. $r = 0.94$

40. $r = 0.9933$. There is a strong, positive linear relationship between the two variables.

41. $r = -0.9890$. There is a strong, negative linear relationship between the two variables.

42. $r = 0.8323$. There is a moderately strong, positive linear relationship between the two variables.

43. $r = -0.3587$. There is a very weak, negative linear relationship between the two variables. No evidence of a linear relationship.

44. $r = -0.9872$. There is a very strong, negative linear relationship between the time and the total number of subscriptions.

As the number of years since 2002 increases, the number of subscriptions decreases.

45. $r = 0.9965$. There is a very strong, positive linear relationship between the days spent hiking, and the distance he has hiked. As the number of days increases, the distance he has hiked also increases.

46. A correlation of -0.84 implies a stronger linear relationship than -0.47 . The closer the correlation is to -1 or 1 , the stronger the correlation. In this case -0.84 is closer to -1 than -0.47 is to -1 .
47. A correlation of -0.73 implies a stronger linear relationship than 0.51 . The closer the correlation is to -1 or 1 , the stronger the correlation. In this case, -0.73 is closer to -1 than 0.51 is to 1 .

48. a)

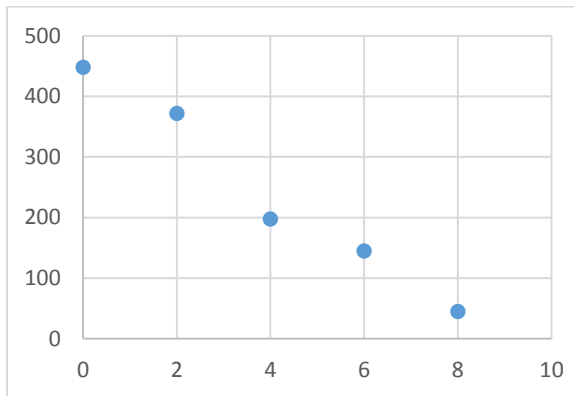

- b) Yes
- c) $S(t) = -51.65x + 448.2$
- d) slope = -51.65 . For each additional year since 2002, the number of newspaper subscriptions decreases by approximately 51,650.
- e) Vertical intercept = 448.2. This means that in 2002, the number of newspaper subscriptions was approximately 448,000.

f) $S(5) = -51.65(5) + 448.2$, $S(5) = 189.95$. In 2007, there will be approximately 189,950 subscriptions.

g) $S(2) = 344.9$. In 2004, there will be approximately 344,900 subscriptions. This value is close to, but not exactly equal to, the actual number from the data table. The regression equation does not fit each data point exactly, but instead provides an overall trend based on the entire data set.

h) No. The year 2030 is too far outside the original set of years (2002 – 2010). Using the regression equation to make predictions this far out is extrapolation and would result in poor predictions. In this case, you would be predicting a negative number of subscriptions!

49. a)

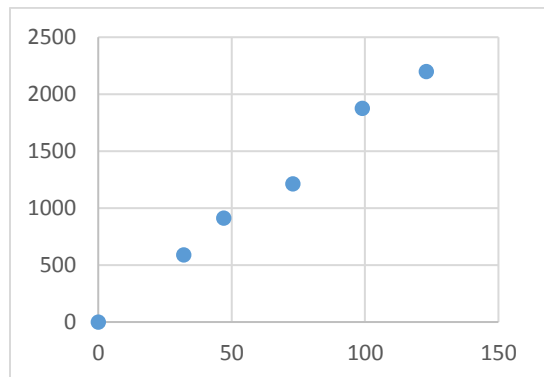

- b) Yes
- c) $D(t) = 18.01t + 9.22$
- d) slope = 18.01. Each day that Scott hikes, he goes approximately 18 additional miles.
- e) $D(50) = 18.01(50) + 9.22$,
 $D(50) = 909.72$. After 50 days, Scott has hiked approximately 909.72 miles.
- f) No. The hike is 2200 miles, so 2500 is not a possible output value from this equation.

11. 69.75
12. 46.67%
13. 69.39%
14. 60
15. 200
16. 30.9%
17. 94.5%
18. 38
19. \$5.25
20. \$20.65
21. \$75.96
22. \$243,750
23. 53.2%
24. Absolute change = $-\$0.12$

Percent change = -3.8%

Chapter 4

1. a) 75%
- b) 80%
- c) 70%
2. 71.4%
3. 77.8%
4. 18.2%
5. a) 23%
- b) 21.5%
- c) 109%
6. a) 0.15
- b) 0.04
- c) 0.075
7. $\frac{1}{5}$
8. $\frac{43}{50}$
9. $\frac{29}{50}$
10. 28
25. Absolute change = \$17,000
- Percent change = 54.8%
26. 20%
27. Increase = 84 parts per million
- Percent increase = 127.4%
28. a) No, we only know their absolute decrease in weight.
- b) Johnny (6.5%)
29. a) 2 percentage points
- b) 12.5%
30. \$4,333.70
31. \$11.70
32. \$13.91
33. \$57.50
34. \$38.00
35. 194 lbs
36. \$26,000

37. \$130
38. \$17,028.27
39. a) 64.3
b) 24
c) 12.44
40. a) 4.63
b) 5
c) 6.30
41. a) 170
b) Decay
c) Decay factor is 0.8
d) Decay rate is 20%
42. a) 5
b) Growth
c) Growth factor is 2
d) Growth rate is 100%
43. a) 110
b) Growth
c) Growth factor is 1.3
d) Growth rate is 30%
44. a) 60
b) Decay
c) Decay factor is 0.7
d) Decay rate is 30%
45. $f(x) = 110(1.035)^x$
46. $f(x) = 1504(1.12)^x$
47. $f(x) = 63(0.72)^x$
48. $f(x) = 545(0.996)^x$
49. $f(x) = 79(2.19)^x$
50. a) Exponential function
b) Exponential function
c) Linear function
51. a) $N(t) = 73t + 970$
b) $N(t) = -36t + 970$
c) $N(t) = 970(0.906)^t$
d) $N(t) = 970(1.061)^t$
e) $N(t) = 970$
52. a) $P(t) = 1944(1.052)^t$
b) 2,772.08
53. a) $P(t) = 17000(0.92)^t$
b) 14,388.8
54. \$30,240.96
55. a) $f(t) = 1000(1.04)^t$
b) $f(t) = 1000(1.04)^{\frac{t}{2}}$
c) $f(t) = 1000(1.04)^{2t}$
(where t is number of years since initial investment)
d) $f(t) = 1000(1.04)^{4t}$ (where t is number of years since initial investment)
56. a) $f(t) = 7400(1.036)^t$
b) $f(t) = 7400(0.98)^t$
c) $f(t) = 7400(1.11)^{\frac{t}{3}}$
d) $f(t) = 7400(0.95)^{2t}$
57. $f(t) = 150000(1.11)^{\frac{t}{2}}$
58. $f(t) = 200000(1.015)^{\frac{t}{5}}$
59. $f(t) = 195000(0.96)^{\frac{t}{3}}$
60. $f(t) = 420000(0.92)^{\frac{t}{4}}$
- Chapter 5**
1. \$210
2. \$77,040

3. \$23,700
 4. \$42,120
 5. \$2727.27
 6. 27.8 years
 7. 23.3 years
 8. 19.6 years
 9. \$1,052.63
 10. \$488.67
 11. \$3,869.68
 12. \$11,458.55
 13. \$2,498.90
 14. \$8,878.56
 15. \$435.56
 16. a) \$3,641.51
b) \$1,641.51
 17. a) \$27,137.65
b) \$17,137.65
 18. \$7,140.96
 19. \$9,250.64
 20. \$6,624.12
 21. \$2,964.38
 22. \$2,206.53
 23. \$3,717.14
 24. \$9,992.02
 25. \$2,224.12
 26. \$5,208.66
 27. a) \$45,244.48
b) \$39,100.00
 28. a) \$6,515.58
b) \$6,000.00
 29. a) \$9,769.44
b) \$2.836%
 30. a) \$3,155.95
b) 5.198%
 31. 3.660%
 32. 5.884%
 33. 4.783%
 34. 2.320%
 35. 5.9%
 36. a) 6.183%
b) 6.168%
c) 6%
 37. a) 16.180%
b) 16.075%
c) 15%
- Chapter 6**
1. \$41,645.91
 2. \$75,387.07
 3. a) \$14,486.56
b) \$10,000.00
c) \$4,486.56
 4. a) \$29,081.87
b) \$18,000.00
c) \$11,081.87
 5. a) \$116,547.38
b) \$72,000.00
c) \$44,547.38
 6. a) \$658.44
b) \$158,025.60
c) \$341,974.40
 7. a) \$796.40
b) \$286,704.00
c) \$513,296.00

8. \$349.53
9. \$232,810.30
10. \$182,158.28
11. \$589,088.84
12. a) \$320,243.29
b) \$750,000.00
c) \$429,756.71
13. a) \$401,447.24
b) \$700,000.00
c) \$298,552.76
14. \$3,582.16
15. \$2,827.12
16. \$3,042.80
17. a) \$130,397.13
b) \$252,000.00
c) \$121,602.87
18. a) \$12,625.50
b) \$15,000.00
c) \$2,374.50
19. a) \$194,346.78
b) \$450,000.00
c) \$255,653.22
20. a) \$141,772.87
b) \$306,000.00
c) \$164,227.13
21. \$546.72
22. \$863.16
23. a) \$180,000.00
b) \$966.28
c) \$1079.19
24. a) \$1,618.79
b) \$282,764.40
25. \$542.38
26. \$974.29
27. \$354.15
28. a) \$265.61
b) \$749.28
29. \$10,033.42
30. \$85,258.61
31. \$76,634.11
32. \$67,283.33
33. a) \$119,023.28
b) \$118,973.37
c) \$108,103.28
d) \$83,093.37
e) Lucy's account has more money overall and Lucy made more interest. Thus, Lucy made the best investment.
34. a) \$129,414.07
b) \$136,686.39
c) \$116,454.07
d) \$93,486.39
e) Nick's account has more money overall. Robert made more interest. When considering who made more money off of a smaller amount of money, Robert made the better investment.
35. \$6,064.67
36. \$1,293.90
37. \$2,398.52

Chapter 7

1. {M, i, s, p}
2. {January, February, March, April, May, June, July, August, September, October, November, December}
3. The set of numbers 3, 6, and 9.
4. The set of letters a, e, i, o, u.
5. Yes
6. Yes
7. Yes
8. a) true
b) false
c) true
d) false
e) false
f) true
g) false
9. a) false
b) true
c) true
d) true
e) false
f) true
g) false
10. $B \subset A$
11. a) true
b) false
c) true
d) true
e) false
f) true
12. {1, 2, 3, 4, 7, 9, 10}
13. {orange, yellow, purple}
14. {2, 8, 12, 14}
15. a) {2, 3, 5, 7, 10, 11, 12, 13, 14, 16, 17, 19, 20}
b) {5, 10, 13, 14, 16, 19}
c) {20}
16. a) {1, 4, 5, 6, 8, 11, 12, 14, 15, 16, 17, 18}
b) {11, 12, 16}
c) {6, 14, 17, 18}
17. a) {1, 2, 3, 4, 5, 6, 8, 9, 11, 12, 14, 15, 17, 18, 19, 20}
b) {9, 12, 14}
c) {5, 17, 19, 20}
18. a) {2, 3, 5, 6, 8, 10}
b) { } or \emptyset
c) {5}
d) {1, 4, 7, 9}
e) {1, 2, 4, 5, 6, 7, 9}
19. a) {s, t}
b) {c, k}
c) {a, b, k, t, h}
d) {a, b, k}
e) {b, c, k}
f) {h}
- 20.

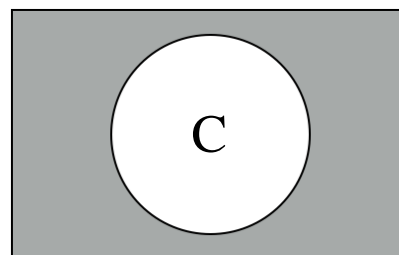

21.

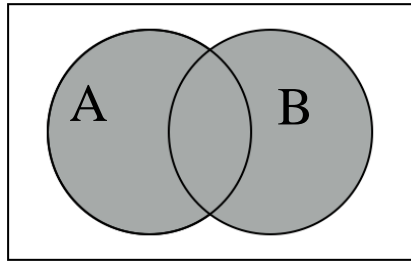

22.

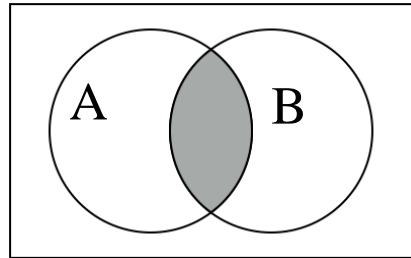

23.

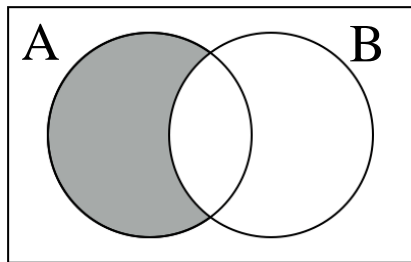

24.

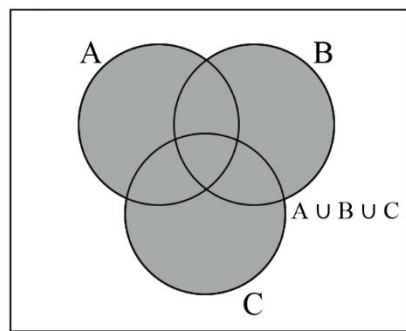

25.

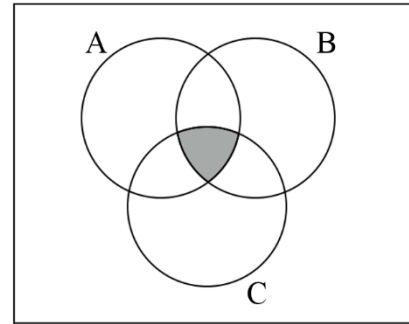

26.

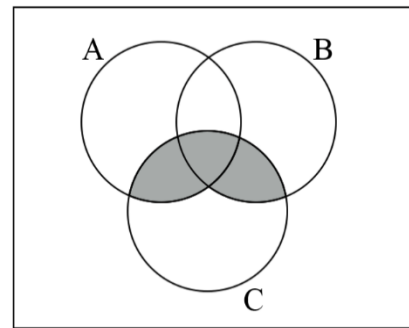

27.

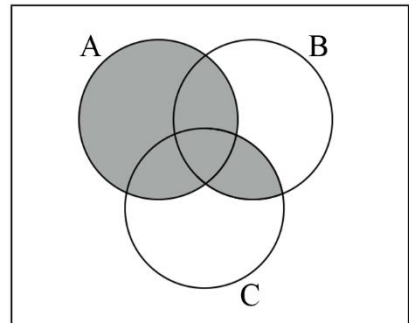

28.

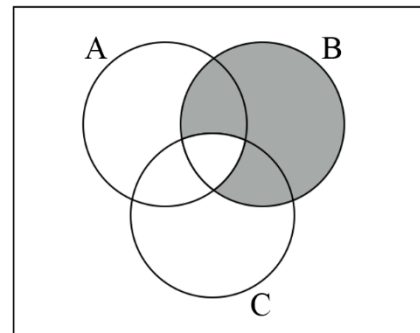

29.

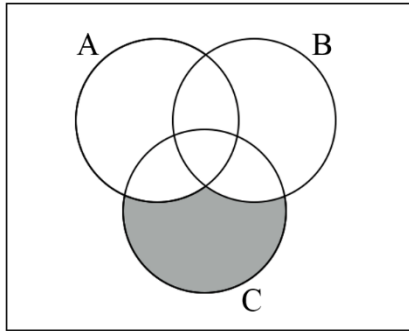

30.

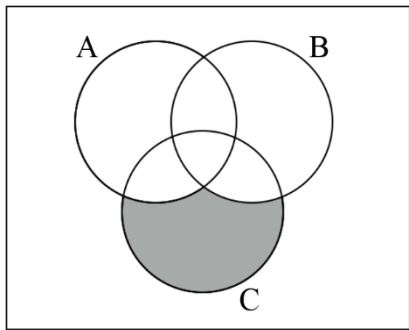

31. $(A \cup C) \cap B$

32. $(\bar{B} \cap A) \cup C$

33. $\overline{(A \cup C)} \cap B$

34. $[\bar{C} \cap (A \cup B)] \cup (A \cap B \cap C)$

35. a) 5

b) 3

c) 6

d) 1

36. a) 3

b) 5

c) 7

d) 4

e) 6

37. a) 23

b) 24

c) 29

d) 18

e) 8

f) 44

g) 21

38. a) 8

b) 15

c) 12

d) 11

e) 2

f) 18

g) 5

39. a) 32

b) 27

c) 52

d) 4

e) 68

f) 37

40. 43

41. 8

42. 22

43.

a.

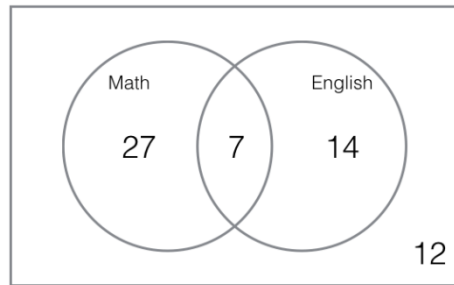

b. 48

c. 39

d. 14

44.

a.

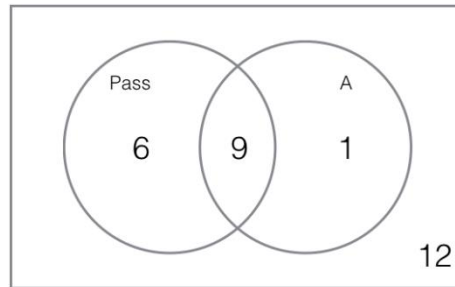

b. 13

c. 6

d. 12

45.

a.

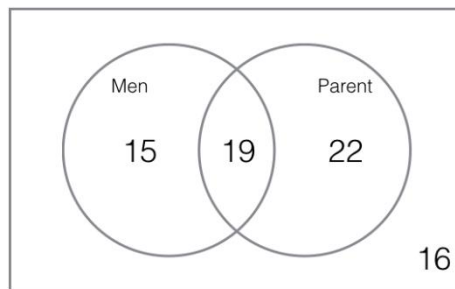

b. 22

c. 16

46.

- a. 28
- b. 8
- c. 11

47.

- a. 24
- b. 11
- c. 13

48.

- a. 44
- b. 25
- c. 10
- d. 35

49. 136

50. 213

51. a) 11% b) 44%

Chapter 8

1. a) $\frac{1}{6}$

b) $\frac{1}{2}$

c) $\frac{2}{3}$

2. 0

3. $\frac{1}{3}$

4. $\frac{11}{12}$

5. a) $\frac{2}{5}$

b) $\frac{8}{13}$

6. a) $\frac{1}{3}$

b) $\frac{2}{3}$

7. a) $\frac{6}{13}$

b) $\frac{2}{13}$

8. $\frac{2}{37}$

9. a) $\frac{21}{26}$

b) $\frac{5}{26}$

10. $\frac{30}{67}$

11. $\frac{41}{81}$

12. $\frac{1}{13}$

13. $\frac{1}{4}$

14. $\frac{51}{52}$

15. $\frac{3}{4}$

16. $\frac{1}{13}$

17. $\frac{12}{13}$

18. $\frac{3}{13}$

19. $\frac{37}{61}$

20. $\frac{7}{45}$

21. 1:5

22. 1:1

23. 1:12

24. 3:10

25. 41:51

26. 7:9

27. 3:1

28. 5:6

29. -\$0.19

30. \$0.03

31. -\$0.17; No

32. \$45.55

33. \$22.00

34. \$40.50

Chapter 9

1. $\frac{1}{12}$

2. $\frac{1}{8}$

3. $\frac{1}{36}$

4. $\frac{1}{4}$

5. $\frac{1}{12}$

6. $\frac{1}{8}$

7. 4.41%

8. $\frac{8}{55}$

9. a) $\frac{1}{169}$

b) $\frac{12}{169}$

c) $\frac{144}{169}$

d) $\frac{1}{16}$

e) $\frac{9}{13}$

10. a) $\frac{1}{156}$

b) $\frac{5}{48}$

c) $\frac{3}{26}$

d) 0

e) $\frac{11}{13}$

11. a) $\frac{2}{5}$

b) $\frac{1}{3}$

12. a) $\frac{1}{2}$

b) $\frac{2}{3}$

13. $\frac{1}{2}$

14. $\frac{1}{6}$

15. a) $\frac{3}{14}$

b) $\frac{2}{5}$

16. a) $\frac{5}{13}$

b) $\frac{2}{11}$

c) $\frac{1}{3}$

17. a) $\frac{6}{17}$
b) $\frac{2}{21}$
c) $\frac{4}{17}$
18. a) 0.0221
b) 0.9997
19. a) 0.0221
b) 0.99998
20. $\frac{1}{663}$
21. $\frac{25}{102}$
22. $\frac{4}{663}$
23. $\frac{253}{9996}$
24. $\frac{1}{12}$
25. $\frac{17}{147}$
26. $\frac{2}{65}$
27. a) $\frac{77}{300}$
b) $\frac{77}{300}$
c) $\frac{11}{60}$
d) $\frac{91}{300}$
e) $\frac{91}{300}$
28. a) $\frac{1001}{6900}$
b) $\frac{77}{690}$
c) $\frac{1001}{6900}$
d) $\frac{33}{460}$
e) $\frac{91}{575}$
29. a) $\frac{10}{65}$
b) $\frac{8}{65}$
c) $\frac{51}{65}$
d) $\frac{44}{65}$
30. a) $\frac{19}{81}$
b) $\frac{10}{81}$
c) $\frac{51}{81}$
d) $\frac{67}{81}$
31. $\frac{5}{52}$
32. $\frac{2}{3}$
33. $\frac{4}{13}$
34. $\frac{11}{26}$
35. $\frac{7}{13}$
36. $\frac{1}{12}$
37. $\frac{5}{7}$
38. $\frac{5}{14}$
39. a) $\frac{5}{8}$
b) $\frac{3}{8}$
40. 0.67
41. 0.78
42. 60 outfits
43. 96 outfits
44. 450 outfits
45. 48 meals
46. 480 one-topping pizzas
47. 67,600,000 license plates

48. 17,576,000 license plates

49. 8,192

50. $26^8 = 208,827,064,576$ or 2.09×10^{11} passwords51. $52^{10} = 1.45 \times 10^{17}$ passwords

52. 100,000 code combinations

53. 4,194,304

54. a) 64

b) 24

55. a) 1,296

b) 360

56. a) 1,000

b) 720

57. 24

58. 9,129,120

59. 840

60. 1.19×10^{13}

61. 495

62. 6,188

63. 15,890,700

64. 120

65. 2,598,960

66. 816

67. 208,606,320

68. 163,350

69. $\frac{26 \cdot 25 \cdot 24 \cdot 23 \cdot 22 \cdot 21}{26^6} = 0.5366$ 70. $\frac{5 \cdot 4 \cdot 3 \cdot 2}{26^4} = 0.0002626$ 71. $\frac{5^5}{26^5} = 0.0002630$ 72. $\frac{1}{16 \cdot 15 \cdot 14 \cdot 13 \cdot 12} = \frac{1}{524160}$ 73. $\frac{91}{17,383,860}$ 74. $\frac{252}{12,271,512}$ 75. $\frac{12915}{12,271,515}$ 76. $\frac{1,287}{2,598,960}$ 77. $\frac{1}{2,598,960}$ **Chapter 10:**

- The representatives in the state's congress
 - $N = 106$
 - $n = 28$
 - 0.5 or 50%
- registered voters in Raleigh
 - $N = 9500$
 - $n = 350$
 - 0.32 or 32%
- people with AIDS
 - the 40 AIDS patients who participated in the study
 - mean length of life of all AIDS patients after treatment begins
 - mean length of life of the 40 AIDS patients in the study after treatment begins
- quantitative
- qualitative
- qualitative
- quantitative
- quantitative
- quantitative
- quantitative
 - quantitative
 - qualitative
 - quantitative
 - quantitative
 - qualitative
 - qualitative
 - quantitative
 - quantitative
 - quantitative
 - quantitative

11. a) b. systematic
b) quantitative
c) qualitative
d) residents using the local park in San Antonio
12. stratified (quota) sampling
13. simple random sampling
14. cluster sampling
15. convenience sampling
16. b. stratified
17. a) convenience
b) cluster
c) stratified (quota)
d) systematic
e) simple random sample, then convenience
18. loaded questions
19. sampling bias
20. response bias and perceived lack of anonymity
21. non-response bias
22. loaded questions
23. voluntary response bias
24. observational study
25. experiment
26. observational study
27. experiment
28. a) group 1
b) group 2 is acting as the control group
c) blind, not enough information to determine if double-blind
d) controlled experiment
29. a) 2nd group (those taking the test medicine)
b) 1st group
c) double-blind
d) placebo controlled experiment

30.

a)

Sport	Frequency	Relative Frequency
Football	5	0.25
Soccer	4	0.2
Baseball	4	0.2
Cheerleading	2	0.1
Basketball	4	0.2
Swimming	1	0.05
Total	20	1

b)

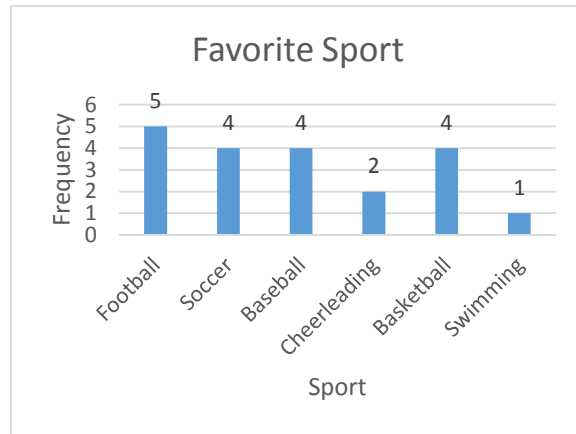

c)

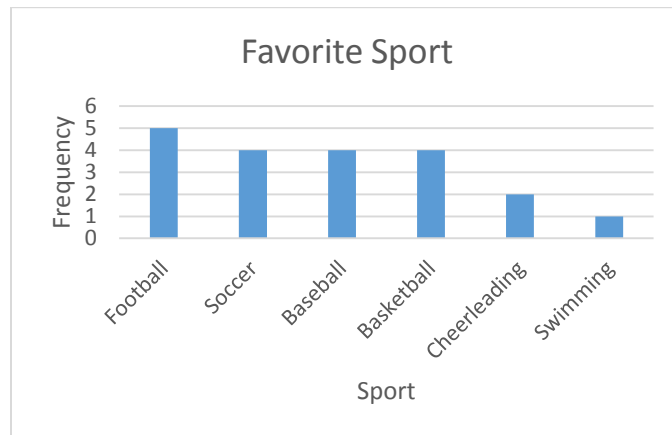

d)

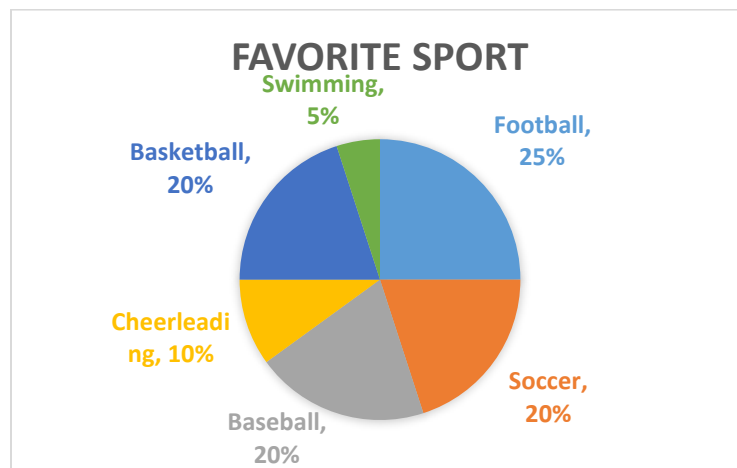

31.

a)

Type of Pet	Frequency	Relative Frequency
Dog	9	0.375
Cat	6	0.250
Bird	4	0.167
Turtle	2	0.083
Hamster	2	0.083
Fish	1	0.042
Total	24	1.000

b)

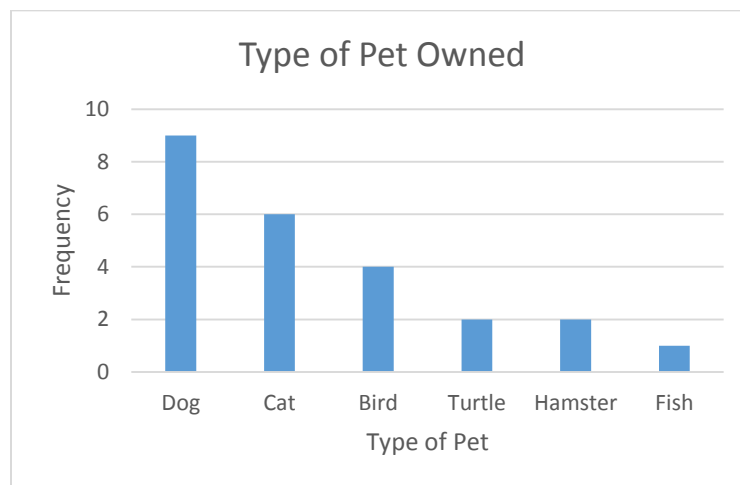

c)

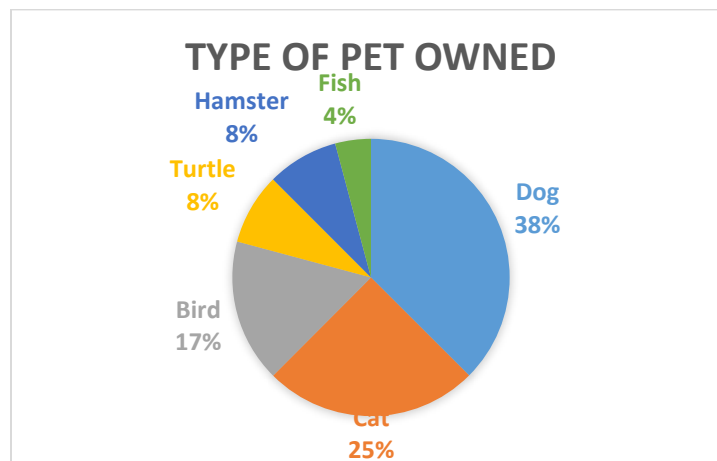

32.

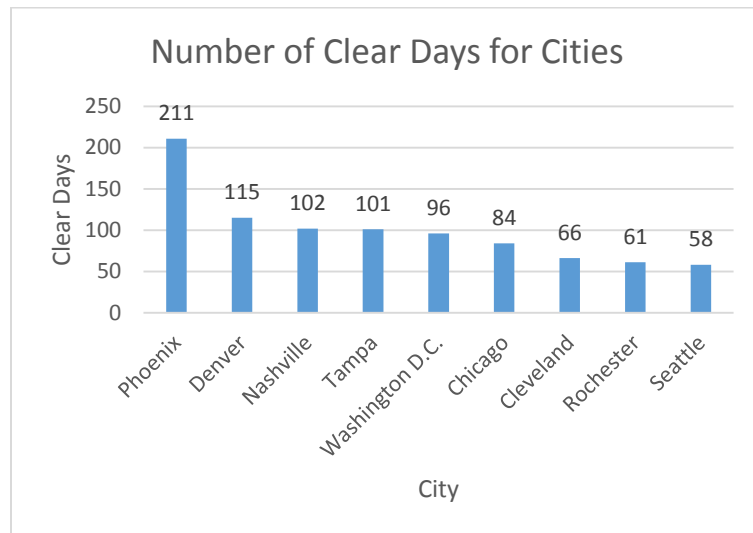

33. $0.25(20) = 5$

34. $0.26(\$2600) = \676

35. The graph needs a title, the axes need to be labeled (including units), the 3D makes the graph difficult to read.

36. a)

Test Score	Frequency
30	1
40	0
50	4
60	3
70	6
80	5
90	2
100	3

b)

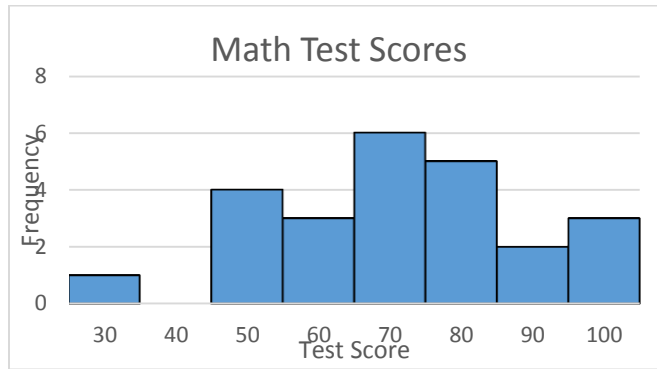

37.

a)

Number of Cars	Frequency	Relative-Frequency
1	9	0.375
2	10	0.417
3	3	0.125
4	2	0.083

b)

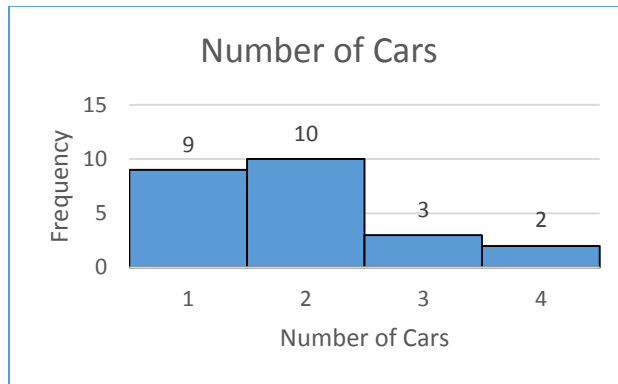

38. a) 15 people b) 33.33%

39. a) 19 orders b) about 21%

Chapter 11:

1.

- a. Skewed
- b. Slightly left-skewed
- c. No outliers

2.

- a. Symmetric
- b. Bell shaped
- c. No outliers

- 3.
- Skewed
 - Left-skewed
 - The exam score of 10 is an outlier.
- 4.
- Symmetric
 - Uniform
 - No outliers
- 5.
- Symmetric
 - Bell shaped
 - No outliers
6. a) \$7.81 b) \$7.75 c) \$0.64
7. a) 20.81 sec b) 19.95 sec c) 4.07 sec
8. 430 and 480
9. a) The mode is “dog”
- b) The mode is the only measure of center useful for qualitative data.
10. a) 0 b) 1.47 c) 1
11. a) 2 b) 2.26 c) 2
12. Mean = \$129,400, Median = \$30,000. The median is a better measure of center for this data set. The mean is pulled toward the one extremely large annual salary. The median is a better representation of what the townspeople earn.
13. a) \$338.40/credit hour b) \$316.04/credit hour
14. a) Answers may vary

Enrollment	Frequency
0 - 5999	16
6000 - 11999	12
12000 - 17999	3
18000 - 23999	2
24000 - 29999	2

b)

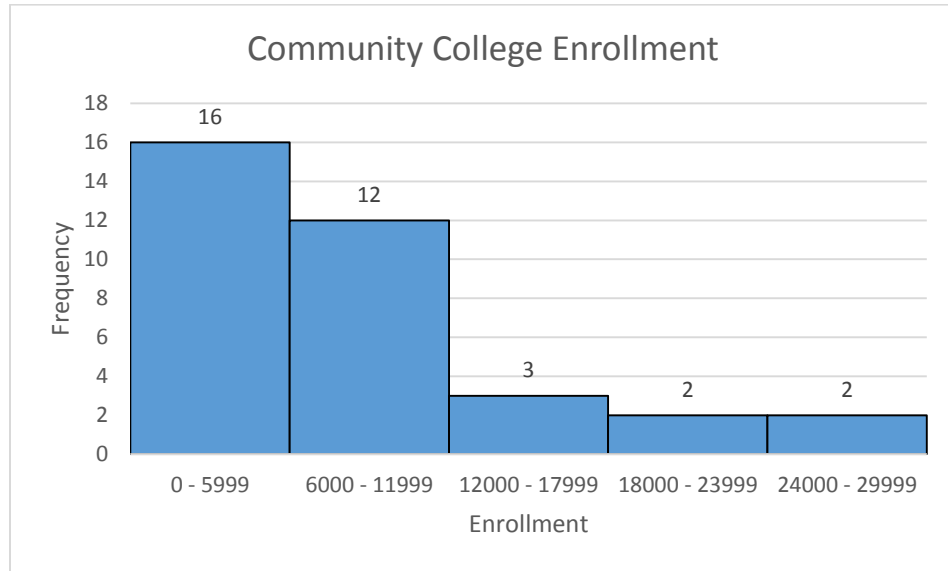

c) 8628.7

d) 6943.9

15. a) Answers may vary

Age	Frequency
21-24	6
25-28	3
29-32	4
33-36	8
37-40	4

b)

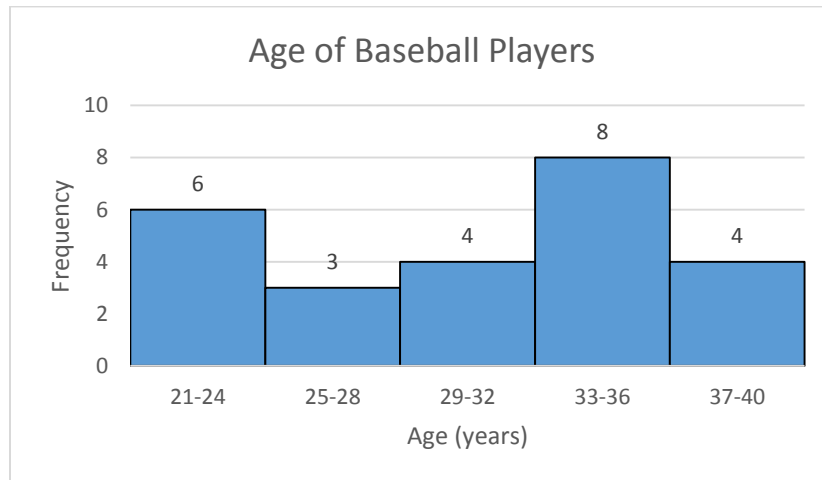

c) 30.68 years

d) 6.09 years

16. a) 1.48 b) 1.12 c) 0, 1, 1, 2, 4

d)

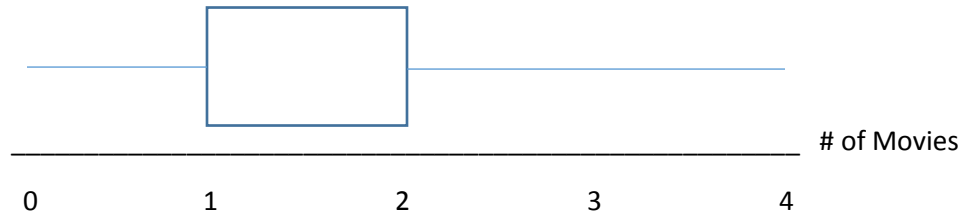

17. a) 1, 3, 4, 5, 7

b)

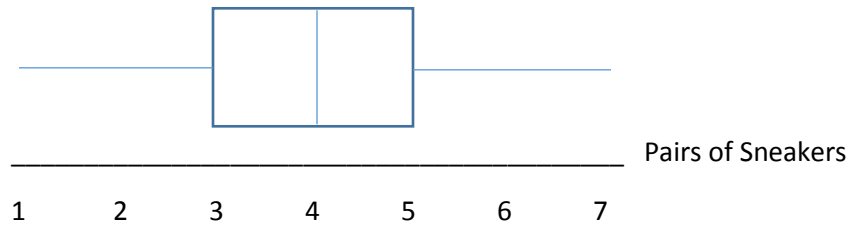

18. a) \$87, \$175, \$218, \$416, \$1300

b)

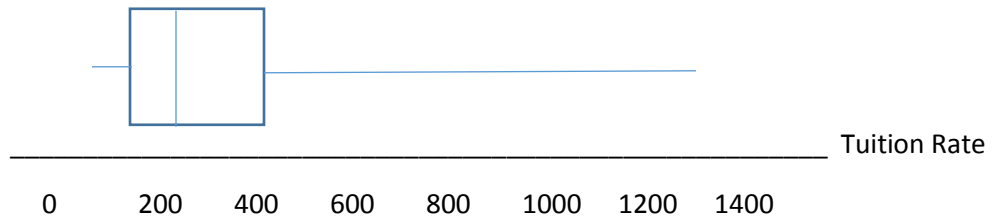

c) \$175 is the 25th percentile

d) \$218 is the 50th percentile

19. a) 236.3 lbs. b) 37.9 lbs. c) 174, 206, 241, 272, 302

d)

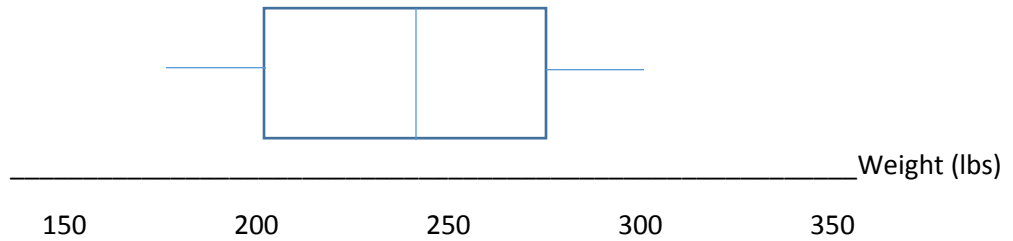

20. a) 3, 4, 4, 6, 7

b)

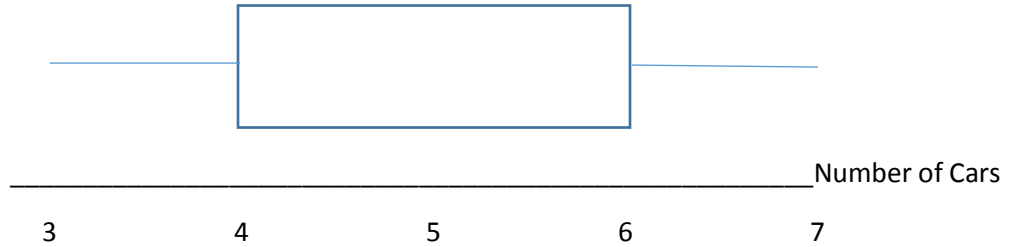

c) The 50th percentile is 4

d) The 75th percentile is 6

21. a) 30, 40, 75, 90, 99 b) 40, 75, 90, 94, 105 c) Kendra makes more money, \$50 thousand more

22. 75%

23. a) 7-series b) 3-series c) No, the age increases with each series and people tend to make more money as they get older.

24. a)

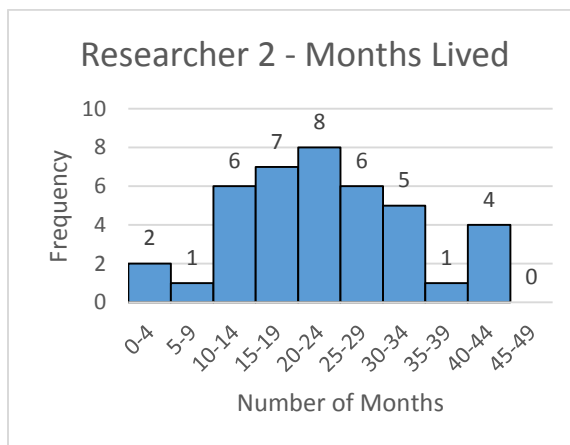
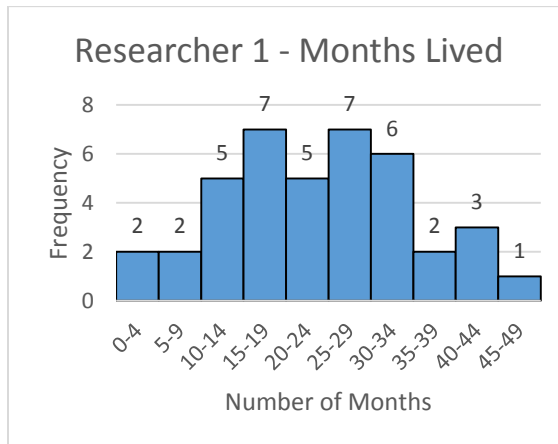

b)

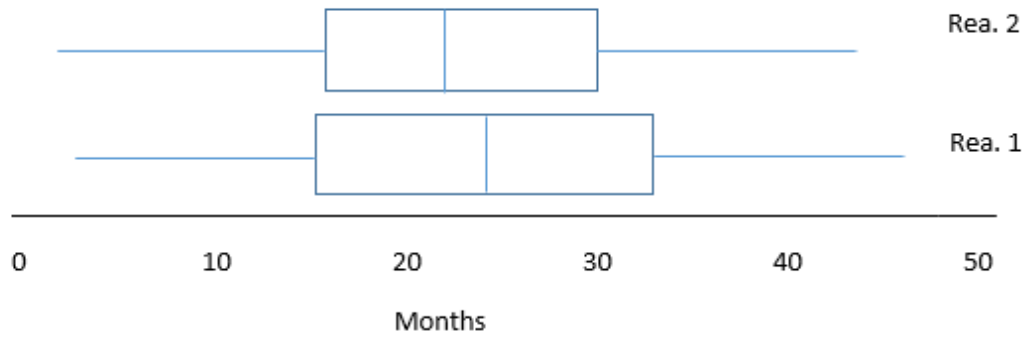

Chapter 12:

1. 61
2. 50%
- 3.

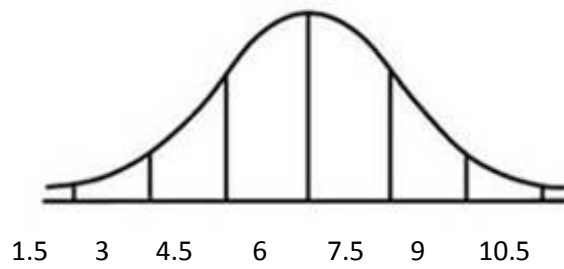

4.

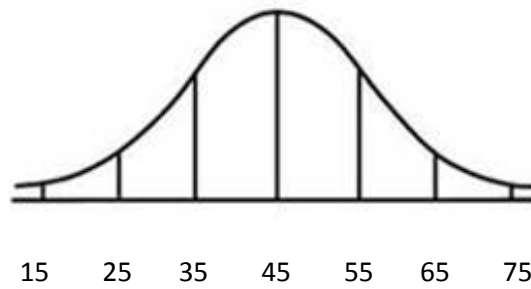

5.

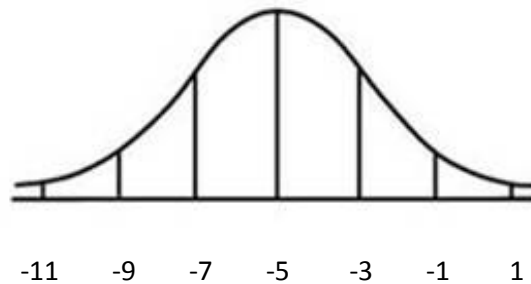

6. Distribution B has a wider spread along the horizontal axes, because it has a larger standard deviation. The spread of the distribution curve is determined by the standard deviation. The larger the standard deviation, the larger the spread of the distribution curve.

7. 68%

8. 95%

9. 4.7%

10. About 1 standard deviation above and below the mean. 68% of the data lies between 12 and 18.

11. About 2 standard deviations above and below the mean. 95% of the data lies between -5 and -1.

12. 49.85%

13. 34%

14. 27%

15. 31.7%

16. A z-score measures the number of standard deviations above or below the mean a particular observation lies.

17. 0; 1

18. $z = 2$ 19. $z = -1.5$ 20. $z = 2.78$ 21. $z = -0.133$ 22. $z = 1.5$ 23. $z = -1.67$

24. $z = 0$

25. $z = -0.33$

26. 1.25; left

27. 0.67; right

28. 6; right

29. 3.14; left

30. 1.7; left

31. $z = -0.85$

32. a) $z = -0.51$. A basketball player who is 77 inches tall is 0.51 standard deviations below the mean height of 79 inches.

b) $z = 1.54$. A basketball player who is 85 inches tall is 1.54 standard deviations above the mean height of 79 inches.

33. a) Blood pressure of 100: $z = -1.79$, Blood pressure of 150: $z = 1.79$

b) I would tell my friend that if his systolic blood pressure was 2.5 standard deviations below the mean, it would be 90. As we just calculated in part a) systolic blood pressure between 100 and 150 actually corresponds to between 1.79 standard deviations below the mean and 1.79 standard deviations above the mean.

34. $x = 20$

35. $x = 5.75$

36. $x = 7$

37. $x = 8$

38. 1.5 years

39. a) An NBA player with a z-score of 3.5 would be 92.62 inches tall. That is just over 7 feet, 8 inches tall. While that height is possible, it's not very likely since it is more than 3 standard deviations above the mean. I probably would not believe him.

b) An NBA player with a z-score of -3.5 would be 65.39 inches tall. That is just over 5 feet, 5 inches tall, which is less than 3 standard deviations below the mean. I would probably not believe him.

40. a) A man with a z-score of 0.75 has a systolic blood pressure of 135.5. This is not an unusual blood pressure, as it's only 0.75 standard deviations more than the average blood pressure of 125.

b) A man with a z-score of 3.2 has a systolic blood pressure of 169.8. This is an unusual blood pressure, since it is more than 3 standard deviations above the mean.

41. $1 - 0.123 = 0.877$

42. $1 - 0.543 = 0.457$

43. a) 0.0912

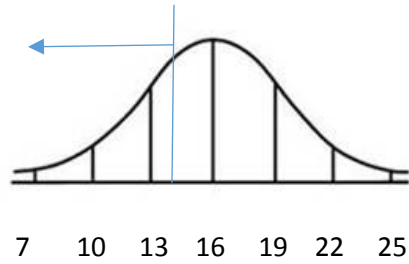

b) 0.9088

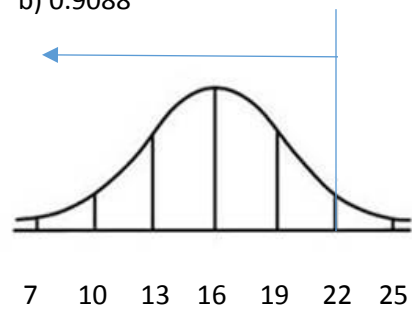

c) 0.6306

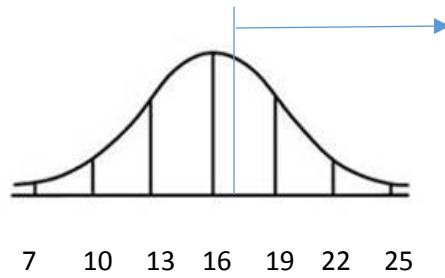

d) 0.0038

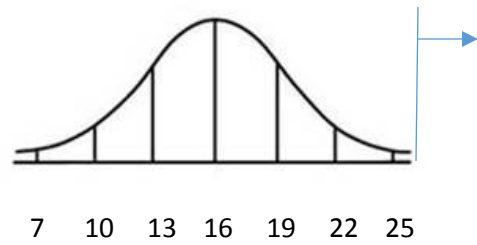

e) 0.8176

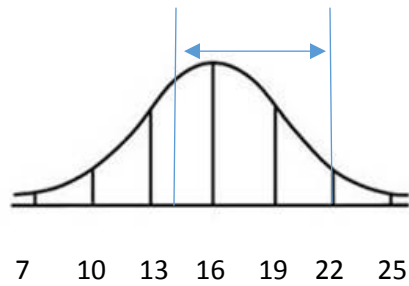

44. a) 0.1035

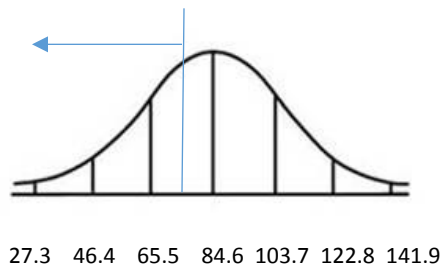

b) 0.8965

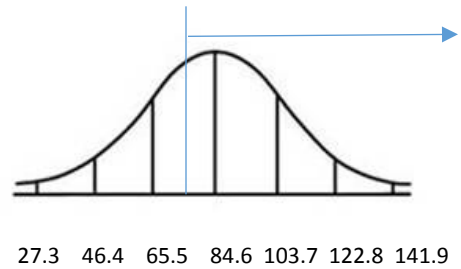

c) 0.9885

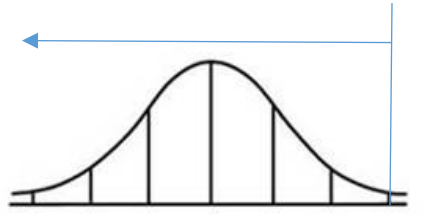

27.3 46.4 65.5 84.6 103.7 122.8 141.9

d) 0.0346

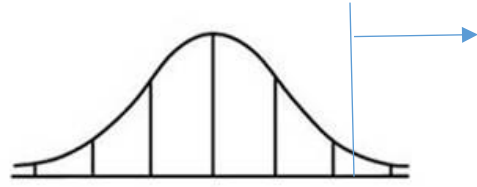

27.3 46.4 65.5 84.6 103.7 122.8 141.9

e) 0.2065

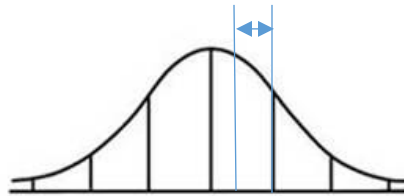

27.3 46.4 65.5 84.6 103.7 122.8 141.9

45.

a) 0.000046

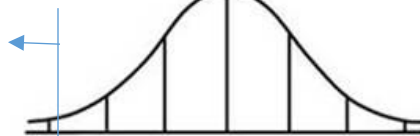

31.2 35.8 40.4 45 49.6 54.2 58.8

b) 0.50

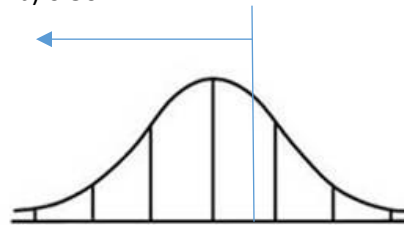

31.2 35.8 40.4 45 49.6 54.2 58.8

c) 0.0640

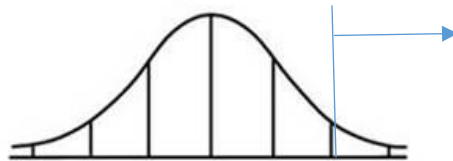

31.2 35.8 40.4 45 49.6 54.2 58.8

d) 0.9360

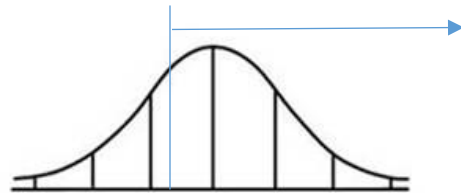

31.2 35.8 40.4 45 49.6 54.2 58.8

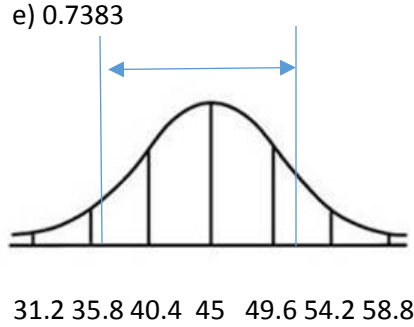

46. a) 0.0580

b) 0.9420

c) 0.0126

47. a) 0.5404

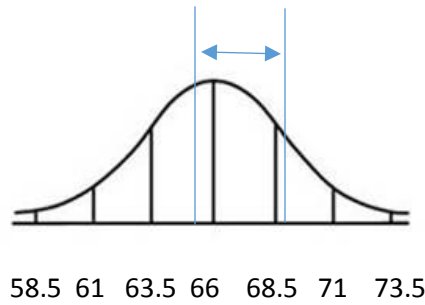

b) An adult Asian male who is 72 inches tall has a z-score of 2.4. The proportion of values greater than $z = 2.4$ is 0.0082. That means that it would be fairly unusual to see an adult Asian male who is over 72 inches tall (only about 0.82% of adult Asian males are over 72 inches tall).

48. a) 0.0912

b) 0.0038

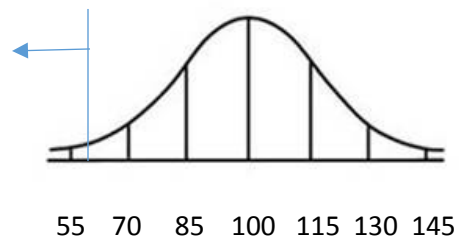
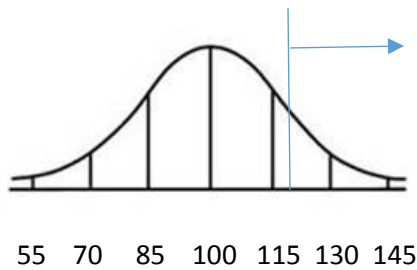

49. a) 0.3446

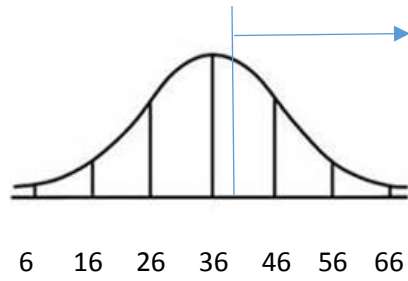

b) 0.0501

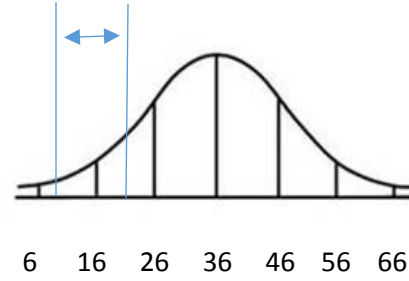

50. a) 0.2743

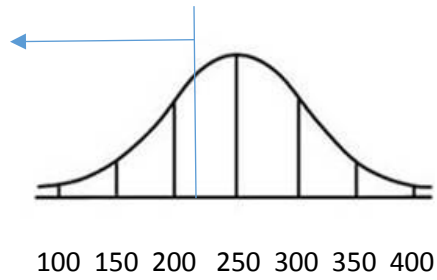

b) 0.0228

